



**SIEMENS**

*Ingenuity for life*

Siemens PLM Software

# What they didn't teach you in school about heat transfer

Mechanical analysis

# Introduction

Heat, like most things, prefers the path of least resistance. But it is not welcomed everywhere. Sometimes, heat is the enemy, such as in the design of consumer electronics, where powerful chips are squeezed into tighter and tighter quarters. Heat generated by an electronic product needs to be removed from its enclosure so that the heat does not accumulate and damage the internal components. For smart phones, the ingenious designers have even taken into account that our body can act as heatsinks; while you use the phone, the heat is transferred out by conduction through the contact to your body.

A huge challenge today for design engineers is the ever increasing product complexity. Manufactured products are evolving into complex systems of mechanical components, electronics, and software, involving multiple engineering disciplines. The increasing number of components, combined with miniaturization, requires an even greater understanding of how these components will interact, while making sure they do not overheat. To add yet another level of complexity, products are

often marketed and sold in multiple configurations, and design engineers must understand the performance of each configuration.

Heat and its behavior are complex. Rules of thumb are often used to visualize the heat path for design or physical prototypes; but knowing how heat is traveling, at what speed and where it will go, is difficult. This is why today's design-centric software for modeling and simulation using computational fluid dynamics (CFD) is integral to understanding heat flow and channeling it correctly without having to build and test as many expensive and time-consuming physical prototypes.

### Best ROI is achieved by simulating early: Frontloading thermal analysis in the design process

CFD software is complex and can be difficult to master, so its use traditionally has been relegated to the final-prototype testing phase and given over to CFD experts or specialists. However, testing a design only at the prototype stage is costly. According to a report by

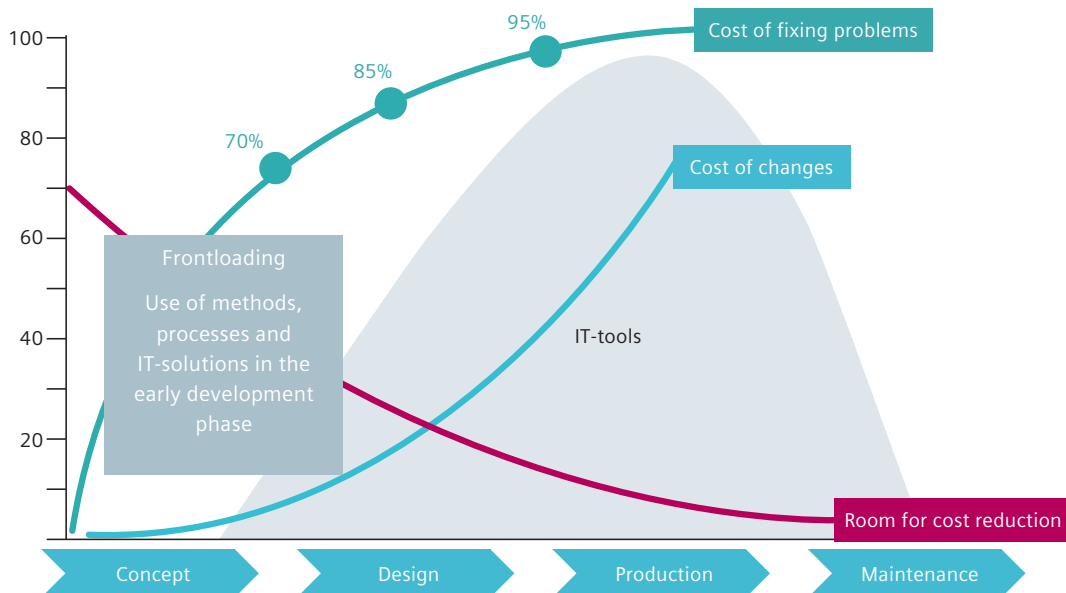

Source: Prof. Dr. Martin Eigner VPE TU Kaiserslautern

Figure 1. Frontloading of simulation can help reduce costs

Lifecycle Insights [1], at this stage, failed designs lead to missing project milestones, extra rounds of testing, and having to work long hours. Multiple surveys conducted by various industry analysts and CAE vendors suggest that the most successful companies assess performance of their designs early during the development process and actively promote collaboration and sharing of knowledge between analysis experts and design engineers.

Reducing the cost of change and building in more room for cost reductions provides the biggest return on investment (figure 1) [2]. Prof. Martin Eigner coined “frontloading” as an umbrella term for the practice of using a whole slew of software simulation tools, including CFD, earlier in the design process [2].

### How frontloading CFD has changed the design process

About 20 years ago, stress analysis was introduced for use during the early design stages, and it quickly became an integral step in the development process. Now, all major MCAD software tools provide design-level stress simulation. However, frontloading stress simulation and conducting analysis early during the design stage did not mean that manufacturers stopped simulating during the validation stage. Simulation simply became a method by which trends were examined and less desirable design ideas were dismissed.

Unlike the verification stage, during the design phase, speed is of the essence. Engineers need to simulate, not only early, but often to keep in step with the speed of design changes. By iterating rapidly, engineers can discount the less attractive ideas and innovate further. Once a design has been explored and identified as viable, it can continue on to the verification stage.

This practice has spread to other areas including CFD analysis. We now have CFD tools that are designer-friendly and are linked integrally and conveniently within CAD tools. Using these combined tools, a prototypical digital twin — a virtual representation of the product — can be created.

The benefits of frontloading CAD-embedded CFD include:

- Better matching to product requirements (for example, lower weight, faster speed, complex behaviors, etc.)
- Reducing downstream development delays and costs (such as reduce testing and prototyping, reduce change orders, etc.)

- Satisfying customer contractual obligations or regulatory requirements
- Reducing product lifecycle costs
- Driving production costs lower

### Why designers need thermal simulation and analysis inside their CAD

Traditional CFD software programs usually consist of multiple interfaces: one for preprocessing, one for solution, and another for post-processing. They also tend to have their own proprietary interfaces that are not integrated with CAD; at best, they offer data translators to move models from CAD to CFD software. Every time a model needs to be analyzed, the data has to be prepared and exported out of CAD and imported into the CFD tool where the model can be “healed” for use.

Also, they are crammed with technology that requires advanced training and education, which is why dedicated analysts are usually assigned the task. For example, most traditional CFD tools support many types of mesh types. The engineer has to know which one would be the most appropriate for the specific application. In addition, he or she will have to work on the mesh until an optimal mesh for the model and application has been achieved. In short, using traditional CFD tools can be extremely time-consuming and slower than is desired during the design stage. As a result of this specialization, the work of analyzing the thermal aspects of a design that affect critical product operation traditionally has been separated from design and development departments. But this labor-intensive approach often led to incomplete results and were limited to readings at discrete locations, so that thoroughly understanding and characterizing underlying thermal behavior was difficult.

In contrast, design-centric CFD solutions:

- Must be fully embedded in CAD: These tools can be easily accessed inside the CAD program, and they use the same native geometry for analysis. Exporting data and healing it in preparation for analysis is no longer required. In addition, the software simply slots in — no learning a new interface is required. CFD analysis is simply another functionality offered by the CAD package
- Add automation: CAD-embedded CFD programs need to have built-in intelligent automation for easier, faster, and more accurate analysis. For example, in heat-transfer analysis, sometimes a designer is

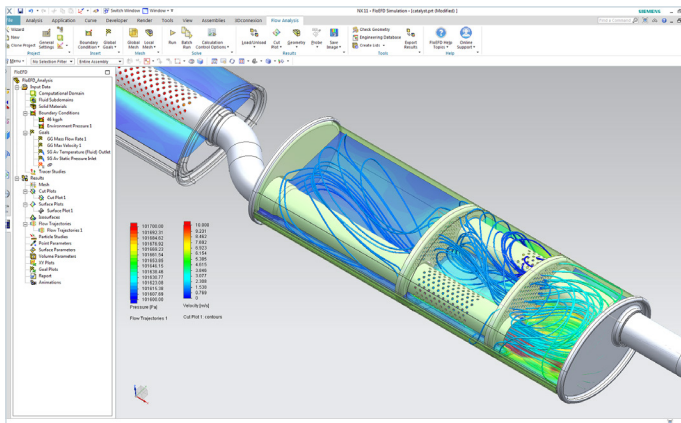

Simcenter FLOEFD for NX

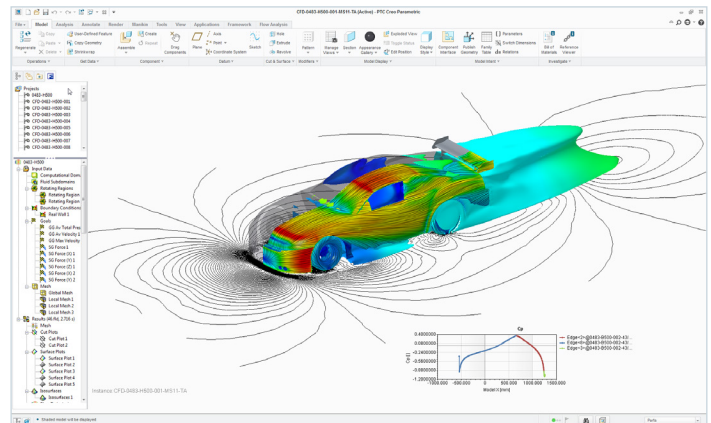

Simcenter FLOEFD for PTC Creo

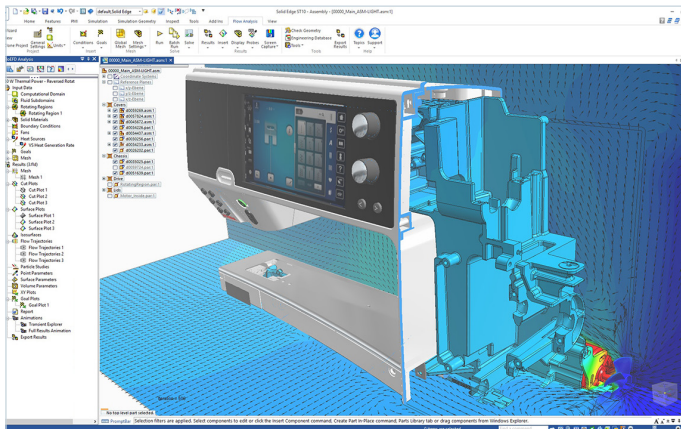

Simcenter FLOEFD for Solid Edge

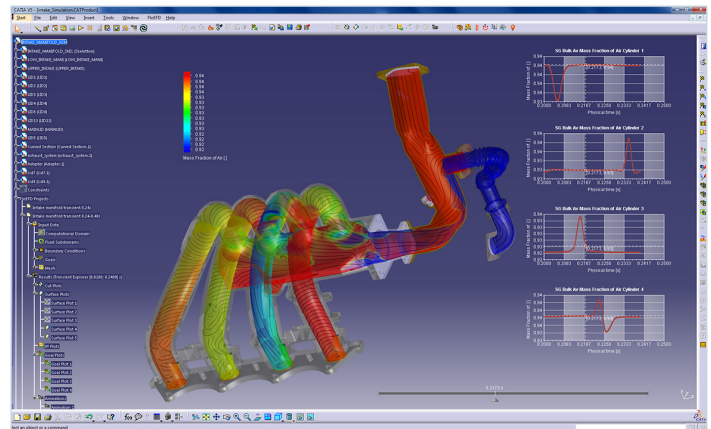

Simcenter FLOEFD for CATIA V5

Figure 2. Simcenter FLOEFD is embedded into popular MCAD programs.

interested in understanding what is happening in the negative space, the empty space where the fluid resides. With traditional CFD, additional geometry has to be created to represent that cavity. Design-centric CFD solutions, on the other hand, are intelligent enough to recognize that the empty space is the fluid domain so that no time is wasted creating geometry to accommodate software. With this new generation of CFD tools, the intermediate step is unnecessary.

Also, before analysis can begin, the model has to be meshed. With traditional CFD, the engineer has to be fully conversant in which meshing method best depicts the flow phenomenon. Designer-friendly CFD uses a fully automated mesher that will automatically generate the best possible mesh for the problem being set up

- Combine speed with accuracy: CFD solutions that can truly be used inside CAD and frontloaded in the design process reduce analysis time significantly — some organizations have reported a time compression of 75 percent. This reduction is made possible by automation and by significantly lowering the need for model preparation and preprocessing

### CAD-Embedded CFD solution

Simcenter FLOEFD™ software is embedded in MCAD toolsets such as CATIA® V5, Creo™ Elements/Pro™, and NX and Solid Edge. It provides a complete environment for performing heat-transfer and fluid flow evaluation. All the phases of analysis are in one package — from solid modeling to problem setup, solving, visualizing results, optimizing the design and reporting.

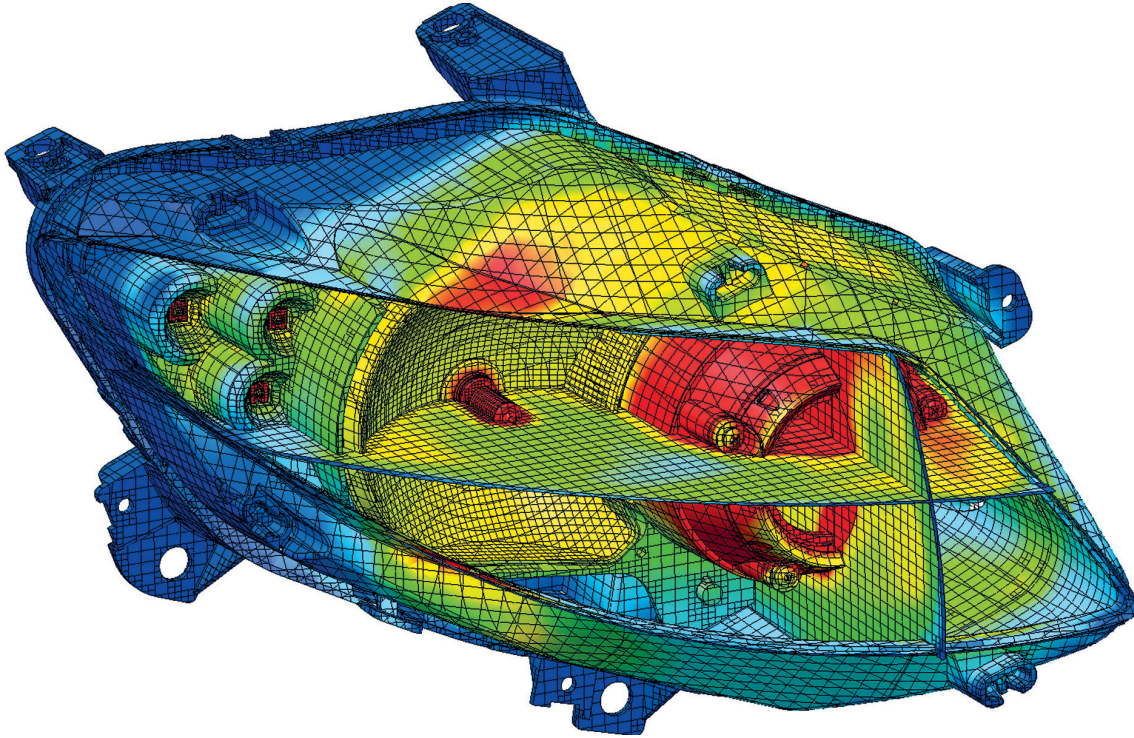

Figure 3. Simcenter FLOEFD SmartCells technology provides accurate analysis results.

With Simcenter FLOEFD, designers can focus on analyzing the details of temperature distribution in the fluid and solid areas of their products. What-if scenarios can be run to analyze complex physical processes such as heat conduction, heat convection, conjugated heat transfer between fluids, surrounding solid materials, radiation, joule heating, and more, then quickly modify and optimize the design's geometry inside an MCAD tool (figure 2).

Simcenter FLOEFD solves for all the three modes of heat transfer (conduction, convection, and radiation), in 3D, which is why it can be used to analyze a wide variety of applications. Typical temperature analysis applications include heat exchangers, injection mold cooling, solar towers, laser systems, and brake design, among others. For example, a designer can look at the efficiency on the thermal side of a heat exchanger but also predict the pressure drop through the heat exchanger. Combining these parameters in one single model helps design a better product earlier.

To use Simcenter FLOEFD software, all that is needed is the installation in the MCAD system and the physics of the product. All the menus and commands necessary to

run a full CFD flow analysis are installed into the CAD menus. On the average, most designers can start using Simcenter FLOEFD on their designs after less than eight hours of training.

The starting point of any heat-transfer analysis is to define the overall boundary conditions of the problem. Simcenter FLOEFD has a wizard that walks users through the setup, including the selection of material properties. Simcenter FLOEFD allows use of existing MCAD models for analysis, without having to export or import additional geometry. The embedded Simcenter FLOEFD toolset can use newly created or existing 3D CAD geometry and solid model information to simulate designs in real-world conditions.

Once a project is created and the boundary conditions applied, the model needs to be meshed, that is, a computational grid has to be built. Developing a mesh is one of those skills that was left up to CFD specialists. Simcenter FLOEFD creates meshes automatically in minutes. CFD-embedded in the CAD program creates an adaptive mesh that reduces the cell size where necessary, increasing the resolution of the analysis, to ensure more accurate simulation results in complex areas of the model (figure 3).

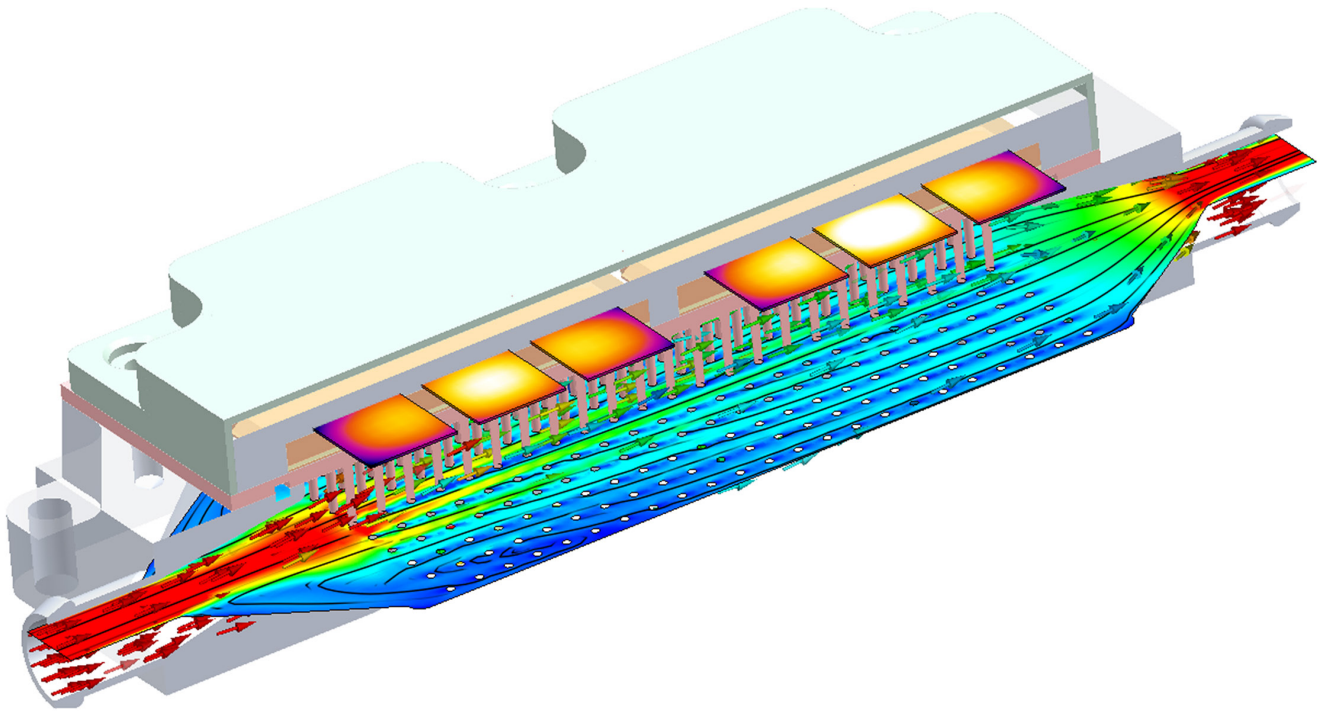

Figure 4. Cut plot showing speed of fluid movement as well as temperature inside an IGBT.

### Design example: Solving advanced heat-transfer challenges

When analyzing heat transfer, building a mesh is important to capture the complex geometry of the system or device. The mesh is simple in concept, yet it is the heart of complex CFD calculations. The surface of the device is mapped into tiny rectangular cells, each of which is split into solid and fluid volumes that are analyzed discretely. The process then develops a composite result that incorporates all of the cells. Simcenter FLOEFD enables visualizing what is happening to a design's thermal dissipation, providing valuable insight to guide design decisions and so the design can be interrogated more thoroughly.

One way to examine the temperature field is to use a cut plot, which depicts the temperature distribution on a plane through the model (figure 4). A cut plot of results can be displayed with any results parameter and

the representation can be created as a contour plot, isolines, or vectors. The cut plot can also be created using any combination, such as velocity magnitude and velocity vectors. In addition to cut plots, a surface plot can be easily displayed for any particular face or automatically for the entire model.

Solving heat distribution problems is an iterative process. After seeing the initial analysis results, most designers want to modify their models to explore different scenarios. Simcenter FLOEFD makes it easy to conduct these what-if analyses. Design alternatives can be explored, design flaws detected, and product performance optimized before detailed designs or physical prototypes are created. This allows quick and easy determination of which designs have promise and which designs are unlikely to be successful.

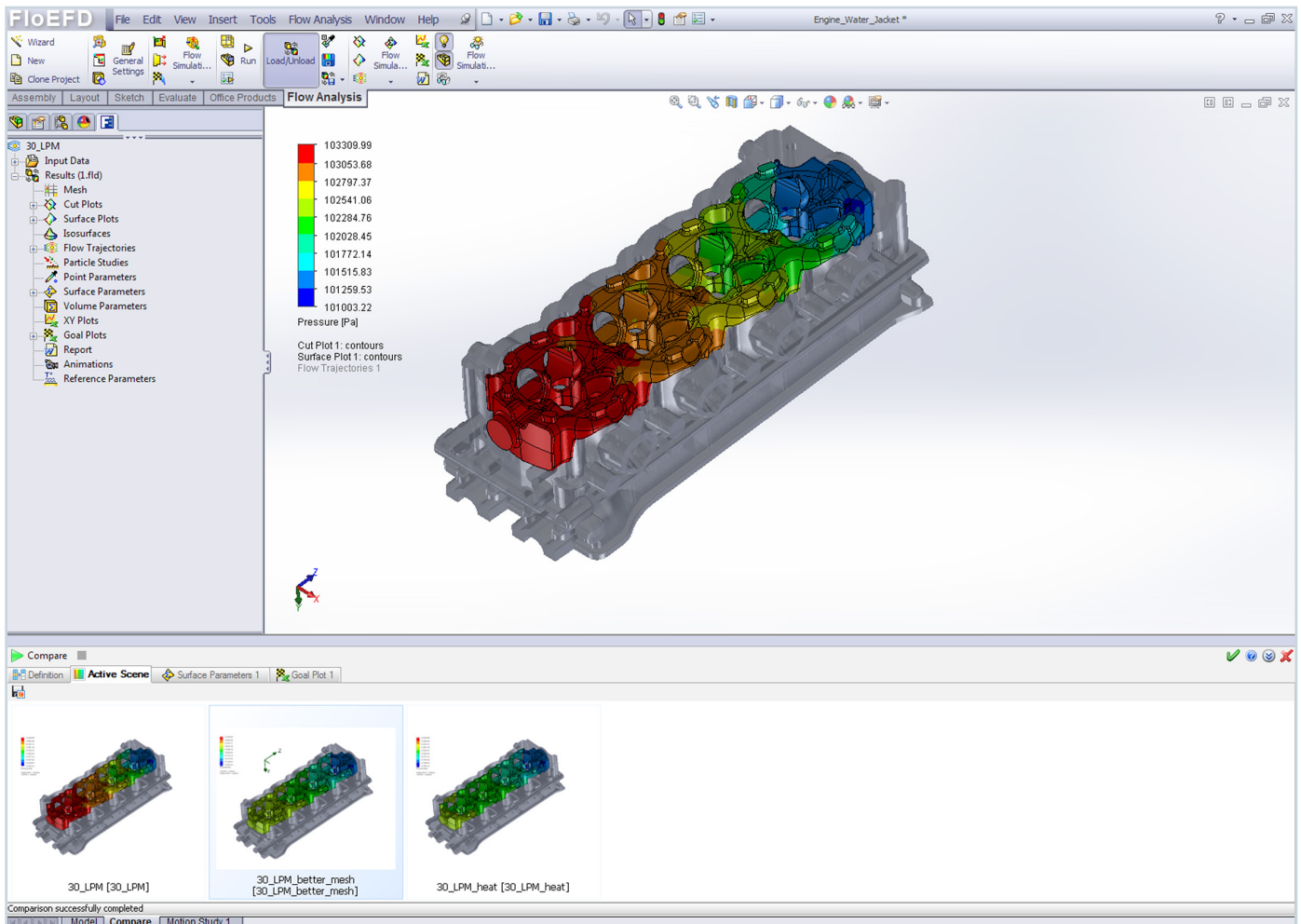

Figure 5. Simcenter FLOEFD parametric study and design comparison functionality helps engineers optimize designs quickly.

Multiple clones of the simulation projects can be made in Simcenter FLOEFD that automatically retain all analysis data such as heat sources and other boundary conditions just for different variations of the geometry.

Simcenter FLOEFD software operates immediately on the changed geometry, creating a new mesh automatically and working with the previously defined boundary conditions. Thus, the step from a changed geometry to running the solver and examining results is greatly accelerated. Its compare configuration and parametric study capability enables users to understand the influence of changes in the geometry or boundary conditions on the results. Users can evaluate the design envelope by assessing results by numerical values, by graphs and by visual images/animation; thereby compare a wide range of project permutations. In these

ways, Simcenter FLOEFD accelerates the iterative design process, allowing knowledge gained in an analysis to be quickly and easily incorporated to improve the product.

Simcenter FLOEFD provides robust verification capabilities for validating designs. Before releasing a new version of Simcenter FLOEFD, Siemens engineers validate the release with a suite of 300 tests. Based on this rigorous verification suite, Simcenter FLOEFD offers 20 tutorial and 32 validation examples, including their documentation, ready for immediate use.

Sharing results and findings is simple. Simcenter FLOEFD is fully integrated with Microsoft® Word® and Excel®, allowing engineers to create report documents and collect important data in graphical form from any

project. In addition, it automatically creates Excel spreadsheets summarizing the outputs of an analysis; thus making the last step in any analysis, creating reports, effortless. Simcenter FLOEFD also comes with a free standalone viewer in order to share selected result plots with your customers in an interactive 3D environment rather than a 2D image.

### Real world designers and Simcenter FLOEFD

Take a look at these real-world examples that demonstrate the speed, accuracy and power of Simcenter FLOEFD in helping designers meet tight deadlines, achieve higher quality results, and keep costs to a minimum.



#### Renault

Engineers at Renault used Simcenter FLOEFD to design better and lower cost automotive headlights.

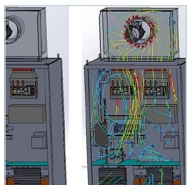

#### e-Cooling

Engineering consultants used Simcenter FLOEFD to design airflow and cooling solutions for power electronics to help their customers bring more reliable products to market.



#### Dr. Schneider

Designers used Simcenter FLOEFD to shorten product development time, quickly find appropriate design variants, save costs, and explain the flow behavior of their car-interior products to colleagues and customers.

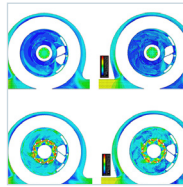

#### Koenigsegg

A design engineer at Halmstad University used Simcenter FLOEFD to evaluate brake-cooling designs for sports cars.

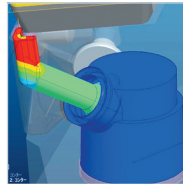

#### Mitsubishi Materials

Prof. Obikawa of the Institute of Industrial Science at Tokyo University collaborated with engineers at Mitsubishi Materials to design a better cooling system for extending lifetime of their machine cutting tools.



#### Mercury Racing

Engineers used Simcenter FLOEFD to help them design the latest inter-cooler filter for their powerboat racing engine.

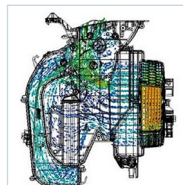

#### Pan Asia Technical Automotive Center

An engineer used Simcenter FLOEFD in the development of automotive HVAC air-handling units

### References

1. 2013. Driving Design Decisions with Simulation. Lifecycle Insights.
2. 2010. Eigner, M. Future PLM – Trends aus Forschung und Praxis: University of Kaiserslautern Blog



## Siemens PLM Software

### Headquarters

Granite Park One  
5800 Granite Parkway  
Suite 600  
Plano, TX 75024  
USA  
+1 972 987 3000

### Americas

Granite Park One  
5800 Granite Parkway  
Suite 600  
Plano, TX 75024  
USA  
+1 314 264 8499

### Europe

Stephenson House  
Sir William Siemens Square  
Frimley, Camberley  
Surrey, GU16 8QD  
+44 (0) 1276 413200

### Asia-Pacific

Suites 4301-4302, 43/F  
AIA Kowloon Tower,  
Landmark East  
100 How Ming Street  
Kwun Tong, Kowloon  
Hong Kong  
+852 2230 3333

## About Siemens PLM Software

Siemens PLM Software, a business unit of the Siemens Digital Factory Division, is a leading global provider of software solutions to drive the digital transformation of industry, creating new opportunities for manufacturers to realize innovation. With headquarters in Plano, Texas, and over 140,000 customers worldwide, Siemens PLM Software works with companies of all sizes to transform the way ideas come to life, the way products are realized, and the way products and assets in operation are used and understood. For more information on Siemens PLM Software products and services, visit [www.siemens.com/plm](http://www.siemens.com/plm).

## [www.siemens.com/plm](http://www.siemens.com/plm)

© 2018 Siemens Product Lifecycle Management Software Inc. Siemens and the Siemens logo are registered trademarks of Siemens AG. Femap, HEEDS, Simcenter 3D and Teamcenter are trademarks or registered trademarks of Siemens Product Lifecycle Management Software Inc. or its subsidiaries in the United States and in other countries. Simcenter, Simcenter Amesim, LMS Samtech Samcef, LMS Samcef Caesam, Simcenter SCADAS, Simcenter Testxpress, Simcenter Soundbrush, Simcenter Sound Camera, Simcenter Testlab, LMS Virtual.Lab, Simcenter Simcenter FLOEFD, Simcenter Flomaster, Simcenter Flotherm, Simcenter MAGNET and Simcenter T3STER are trademarks or registered trademarks of Siemens Industry Software NV or any of its affiliates. Simcenter STAR-CCM+ and STAR-CD are trademarks or registered trademarks of Siemens Industry Software Computational Dynamics Ltd. All other trademarks, registered trademarks or service marks belong to their respective holders.

75931-A7 11/18 Y