

INTEGRATING REVERSE ENGINEERING INTO CORE DESIGN

LEVERAGING A SINGLE ENVIRONMENT WITH
PARAMETRIC, DIRECT, AND FACET MODELING

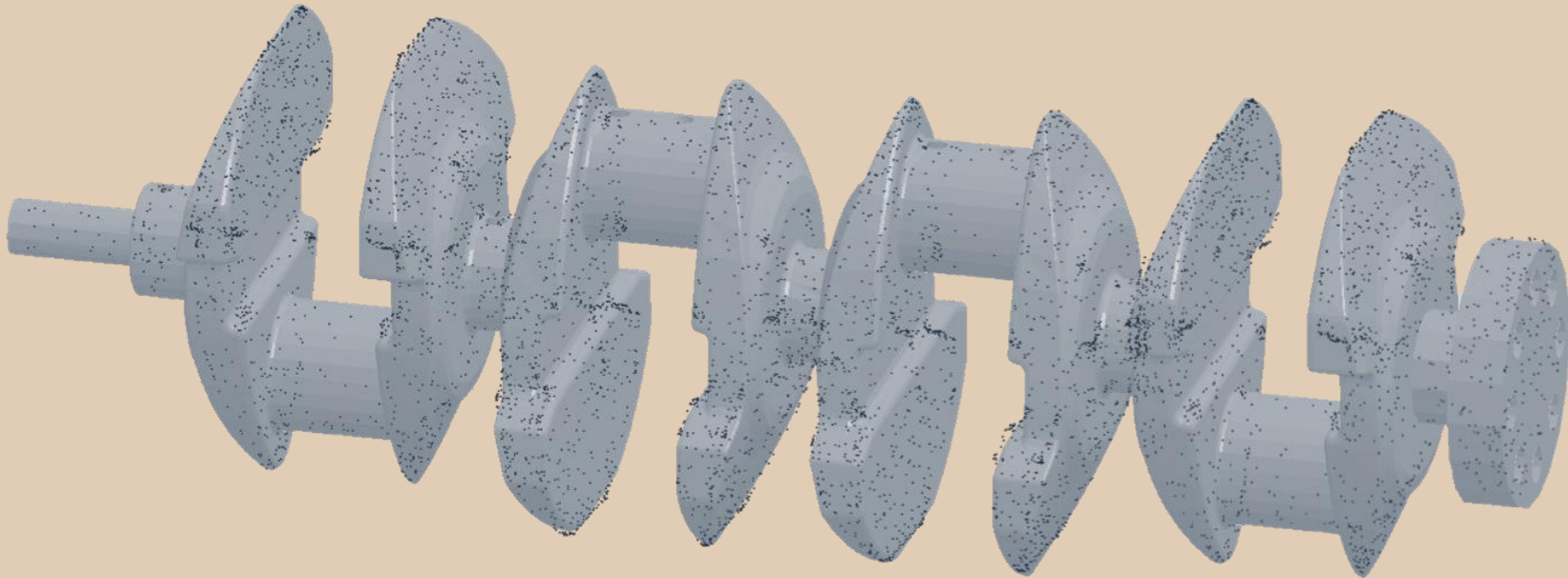

LIFECYCLE

INSIGHTS

DIGITAL FRICTION IN THE REVERSE ENGINEERING PROCESS

Reverse engineering has always been an important activity in design. The practice, in which engineers deconstruct and analyze an existing physical thing to understand how it was designed, has always provided a means to reproduce products. Some teams use it to replicate competitive products. Others employ it to recreate components for which no engineering documentation exists. Still others leverage as a means to identify the root cause of failures. It gives engineering organizations an important capability.

Despite the significant role that reverse engineering plays in design, its integration into modern digital development processes has been lacking. Engineers must often turn to a variety of complicated and unintegrated software applications to complete the job. A large amount of friction in that digital workflow undermines the effectiveness of reverse engineering activities. That friction erodes engineers' productivity and limits the time they can devote to design and development.

However, new technology is promising to eliminate the digital friction associated with reverse engineering. Software tools that provide the right mix of capabilities to complete the entire workflow in a single environment are emerging. That, in turn, allows engineers to recoup their productivity.

Therein lies the focus of this eBook. It examines the details of reverse engineering and discusses how the process fits into concept design, detailed design, prototyping, and testing. It also delves into the traditional and progressive digital solutions that support reverse engineering, highlighting their pros and cons.

Reverse engineering is a critical part of design. It's time the proper tools were available to support it.

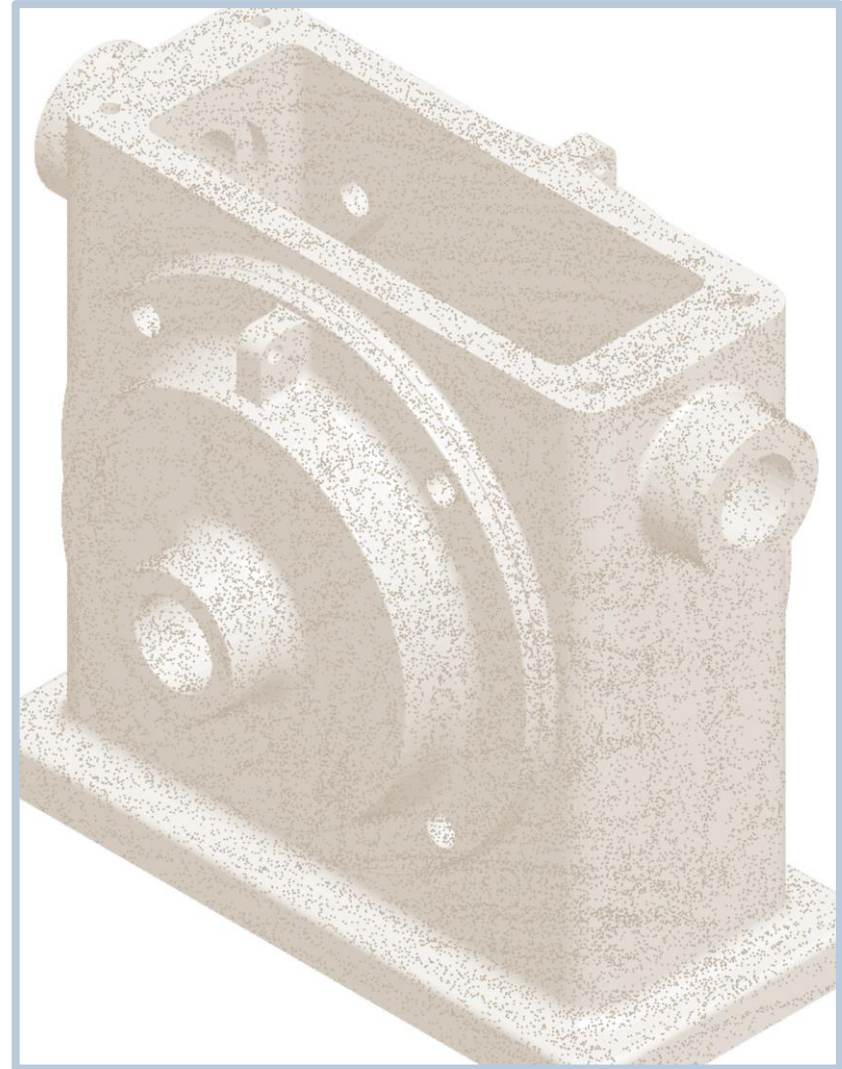

REVERSE ENGINEERING IN THE DEVELOPMENT PROCESS

Before discussing the technology used to support reverse engineering, it is important to understand the basics of reverse engineering. This section covers how and why it is used in the development process, explains technical issues that need to be considered, and explores how it is used in the concept design, detailed design, prototyping, and testing stages.

APPLICATIONS OF REVERSE ENGINEERING

There are numerous circumstances during the development process in which reverse engineering is beneficial, despite the friction in executing its digital workflow. The common thread running through such cases is that the organization does not have engineering documentation. Common reasons for this include the following:

- The product or component was developed before good configuration and control practices were put into place.
- The product or component was developed by a company that has since been acquired, and the documentation was lost or misplaced during the transition.
- If the product or component was part of a startup, documentation may have never been developed.
- The product or component may belong to a competitor, either still operating or not.
- A organically shaped design is first developed physically and needs to be converted into a digital definition.

The reasons an engineering organization may need to leverage for reverse engineering in their development process can vary widely, including the following:

- A product or component operating in a longstanding operating cycle has broken or must be replaced. The organization must replicate the existing product or component as a replacement. Alternatively, the organization needs to understand the root cause of the failure to avoid issues in the future.
- The organization aims to develop the next generation of an existing product or component. They need a digital representation of the existing item to use as the starting point for a new design.

TECHNICAL CONSIDERATIONS

A modern reverse engineering process starts with the technical step of scanning the existing product or component. During this process, a laser scanner takes hundreds or thousands of three dimensional measurements of the item. Each measurement has an X, Y and Z location in space. Collectively, this point cloud represents the outer surface of the item. This, however, is not where the process stops. It is often where it begins.

Once the item is scanned, the point cloud can be used to create a Solid Model, the geometry of which is different from the smoothly rounded geometry created by Parametric and Direct Modeling. Solid Model Geometry is generated by creating planar facets between any three of the points in the cloud. The result is Mesh Geometry that cannot be manipulated, modified, or edited using Parametric or Direct Modeling capabilities. Instead, Facet Modeling enables changes to this geometry.

REVERSE ENGINEERING IN CONCEPT DESIGN

In concept design, engineers develop a range of ideas that could potentially fulfill the form, fit, and function requirements at hand. Initially, they seek designs that feasibly meet those requirements. Then, depending on the role that design plays in the larger product or system, the engineer explores more alternatives or moves on to another design.

The digital geometric representations of these designs can vary widely. Some use top down design techniques to cordon off volumes and spaces for specific components. Others flesh out these ideas with 2D or 3D sketches developed from curves, lines, surfaces, and other simple geometry. However, at this stage, these representations are not usually fully detailed 3D models. Those are created during detailed design.

Reverse engineering can play multiple roles in concept design. One application is to capture the size and shape of an existing product or component as the context of the new design concept. This capability lets engineers design around the existing item and assess whether their requirements have been satisfied. In this scenario, there is little need to transform the Mesh Geometry of the scanned component into a smoothly rounded model. It can fulfill that function as it exists.

Another role for reverse engineering is to utilize the scanned component as a starting point for a new concept. The new idea might inherit some of the traits and characteristics of the existing item, yet diverge significantly in other areas. In this context, the Mesh Geometry serves as a guideline for creating new geometry using traditional methods, including Parametric and Direct Modeling.

A third, but critically important, case involves using the Mesh Geometry of the scanned component directly. Using Facet Modeling capabilities, the engineer can directly change the Mesh Geometry. This includes adding or removing material. It might include modifying the Mesh Geometry as well. Here, it is important to be able to mix and match both smoothly rounded geometry created with Parametric and Direct Modeling alongside the Mesh Geometry created and modified with Facet Modeling. In this scenario, it may not be necessary to transform that Mesh Geometry into smoothly rounded geometry, especially if the item will be produced using additive manufacturing.

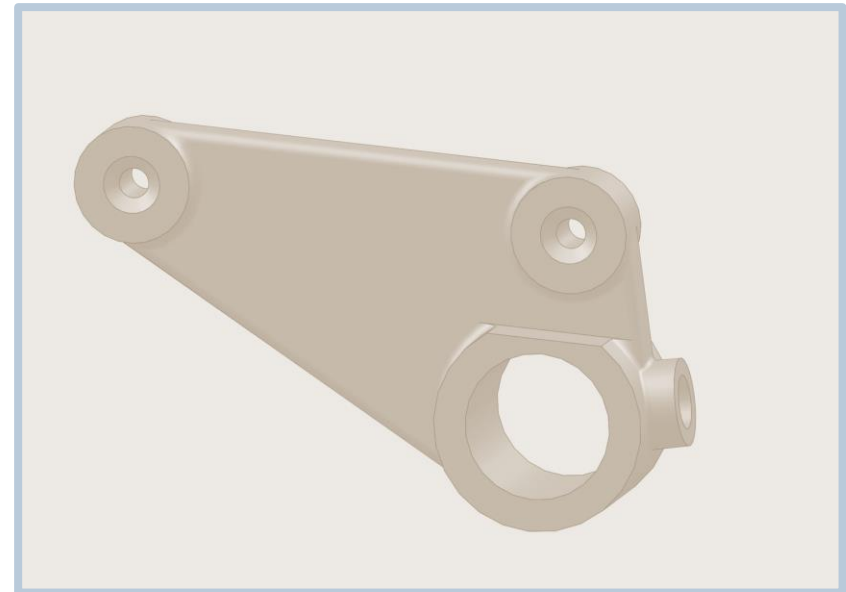

REVERSE ENGINEERING IN DETAILED DESIGN

At this point in development, engineers take a vetted design concept and fully detail it for design release, verifying that it fulfills form, fit, and function requirements along the way. This requires them to explore options for different aspects of the design in an effort to improve performance. This is especially true of engineers who seek the right balance between competing requirements such as weight and structural carrying load, cost, and natural frequencies.

The digital geometric representation of the design at this phase is a fully detailed 3D model. These models are frequently built using Parametric and Direct Modeling capabilities that result in smoothly rounded geometry.

As was the case with Concept Design, reverse engineering plays many roles in Detailed Design. The Mesh Geometry from a scanned product or component can be used as the context for Detailed Design. Many other designs can be developed around that item while checking requirements. In this scenario, there is little need to transform the scanned item into a smoothly rounded model.

Reverse engineering can also provide the basis for a new detailed design. The scan of the item can be used as a guide to create new, smoothly rounded geometry using Parametric and Direct Modeling capabilities. This lets engineers accelerate their work instead of starting from a clean sheet.

Another use for reverse engineering is to use the Mesh Geometry as the detailed design. Facet Modeling capabilities can be used to modify and tweak the Mesh Geometry, including adding or removing material, for any changes that are necessary. This model can be released for manufacturing, especially if additive approaches are used for production.

In each of these cases, the ability to mix and match Parametric, Direct, and Facet Modeling capabilities is crucial. It lets engineers modify the Mesh Geometry, either as the design geometry or as a reference. Furthermore, it lets engineers create smoothly rounded geometry, as needed.



REVERSE ENGINEERING IN PROTOTYPING AND TESTING

When a design gets to Prototyping and Testing, it is physically built and tested. The objective is to verify that the design does, in fact, fulfill all of the allocated requirements. Additionally, a released design might reenter this phase if it fails. Prototyping and Testing can be used to identify the root cause of the failure before developing a modification.

From a geometric perspective, the first time a detailed 3D model is formally transitioned from the digital realm to the physical one occurs during Prototyping and Testing. This requires the use of manufacturing capabilities, such as generating CNC toolpaths or 3D printing, which are leveraged to make the design in the physical world.

One of the primary uses of reverse engineering in Prototyping and Testing is to quickly replicate an existing product or component for the sake of validating the performance of other designs. Here, reverse engineering is used to reproduce an existing item. Then it is used alongside new designs for testing purposes. In this case, no changes are made to the item that has been recreated.

A similar but slightly different case is the use of reverse engineering to duplicate an existing item to identify the root cause of a failure. The purpose here is not to explore or verify any design changes, but instead to understand how and why the item failed. Once that is clear, the organization can pursue a new design effort to modify or replace that existing item with something new.

Another use of reverse engineering is to mock up potential changes to an existing product or component and then quickly test it physically. In this scenario, it is not only important to develop a quick 3D model from the scan, but also to make modifications to the Mesh Geometry swiftly and easily.

As was the case with Concept Design and Detailed Design, the ability to mix and match Parametric, Direct and Facet Modeling capabilities is critical for reverse engineering in Prototyping and Testing. It allows engineers to change the Mesh Geometry, either as the design geometry or as a reference. Moreover, it lets engineers create smoothly rounded geometry, as needed.

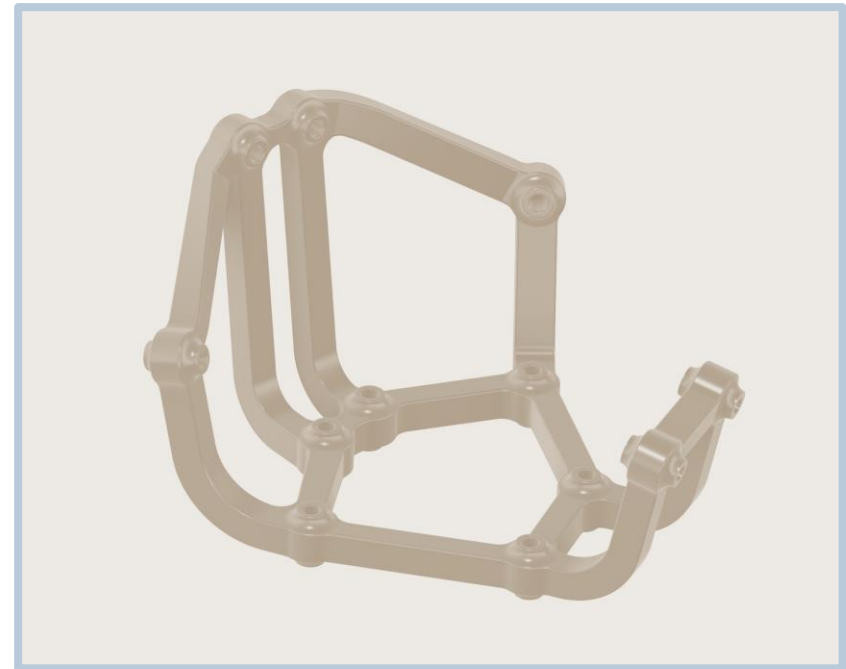

THE TWO APPLICATION SOLUTION

In Concept Design, Detailed Design, and Prototyping and Testing, reverse engineering is an important core design activity.

However, the traditional technologies used to support reverse engineering, an unintegrated couple of software applications, inherently have high amounts of friction in the digital workflow.

TWO GEOMETRY TYPES, THREE MODELING TYPES

In general, traditional geometry modeling takes one of two forms: Parametric or Direct. Parametric Modeling can be used to create a model feature-by-feature, using parametric dimensional controls. Direct Modeling modifies existing geometry by pushing, pulling, or dragging it. Both of these modeling approaches work with 'boundary representations,' in which the geometry is represented by flat or smoothly curved surfaces.

Mesh geometry, by contrast, contains a cloud of points representing the outer surface of a design. Some CAD applications turn this into solid geometry by creating planar triangles or trapezoids and stitching them together into a 'watertight' solid. Facet Modeling lets engineers tweak the quality of the resulting mesh as well as modify that geometry by adding or removing material.

As noted earlier, there are cases where engineers need to develop smoothly rounded geometry as well as Mesh Geometry. In Concept Design, engineers need to work with the sketches and spaceclaims alongside the Mesh Geometry of scanned components. In Detailed Design, they need to create detailed 3D Models taking Mesh Geometry into account. In Prototyping and Testing, they need to quickly produce components from these boundary representations and Mesh Geometry.

THE TWO APPLICATION SOLUTION

Traditional CAD applications used for building 3D models and other items often use some combination of Parametric and Direct Modeling, both of which result in boundary representations. Together, this powerful combination of modeling tools can be used quickly and easily to develop design concepts and detailed designs, and to produce physical components. Unfortunately, very few offer Facet Modeling alongside these conventional capabilities.

Because most CAD applications are unable to work with Mesh Geometry, engineers must turn to other solutions to get the job done. Some standalone specialty applications, typically ones that offer the laser scanning hardware, provide a CAD-like application that includes Facet Modeling. Theoretically, engineers can use both traditional CAD applications and these specialty CAD-like applications together. However, there are numerous drawbacks to this scenario.

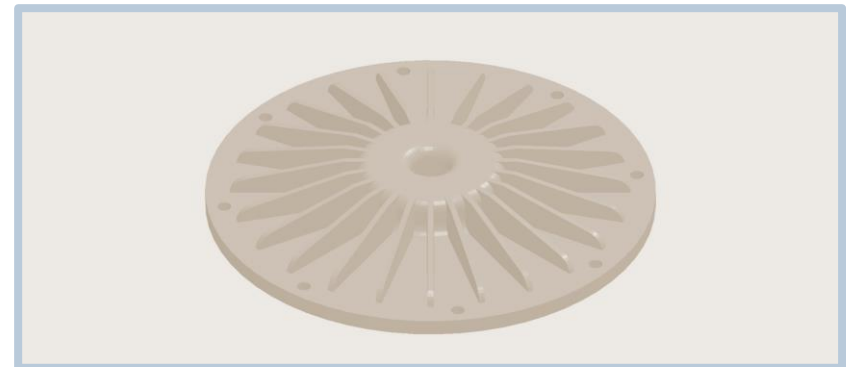

LACK OF A SINGLE ENVIRONMENT

There are many cases in Concept Design, Detailed Design, and Prototyping and Testing where engineers need to combine Parametric, Direct, and Facet Modeling **interchangeably**. For instance, the user might work on facet data, then built a parametric feature, then modify something with direct modeling before using facet modeling again. If these three capabilities do not exist in a single software application, then designers and engineers simply cannot complete this kind of workflow. Instead, they need to find a means to move the design data between the traditional CAD application and the specialty CAD-like application.

EXCHANGING DESIGN DATA

If you are familiar with the exchange of geometry between CAD applications, then you are likely familiar with the issues here. Moving a model from one software application to another often results in misaligned or missing surfaces, lines, or points. This ‘breaks’ the model, because it no longer represents the design, and engineers must fix these sorts of problems every time geometry moves from one type of software to another.

Moving geometry back and forth between traditional CAD applications and specialty CAD-like applications is no different. This handoff is subject to the same issues. The result is more time lost for the engineer and a likely setback for the development project.

TAKEAWAYS

It is possible for engineers to use traditional CAD applications alongside specialty CAD-like applications to enable reverse engineering, but not without significant friction in the digital workflow. It does not allow engineers to use Parametric, Direct, and Facet Modeling interchangeably, which constrains their design freedom. It also translates into a significant amount of time to fix design data exchanged between these two software applications. While alternative solutions would have been preferred for years, this was the only means of running reverse engineering processes in product development.

THE SINGLE APPLICATION SOLUTION

In the past year, new technology has emerged that enables faster and easier reverse engineering in the development process. Some CAD applications have expanded their capabilities to include Parametric, Direct, and Facet Modeling. Beyond importing point cloud data and creating the resulting Mesh Geometry, there are critical implications for the application of reverse engineering.

When engineers need to create boundary representation geometry from the scan data, the workflow gets simpler. All modeling capabilities are in a single environment, which means engineers can use the right tool for the situation at hand.

In another interesting case, engineers don't necessarily need to transform scanned components into boundary representation geometry. Facet Modeling provides the tools to change the design without those time intensive extra steps. This is especially true of components produced using 3D printing, which is already dependent on Mesh Geometry.

In cases where a reverse engineering component needs to be used as the context for new designs, the workflow also gets much simpler. Engineers simply read in the point cloud and scan using Parametric and Direct Modeling capabilities as needed. The scanned component acts as a reference.

An important point in all these scenarios is the activities that this new breed of CAD applications lets engineers avoid: *exchanging design data*. Because all of these capabilities exist in a single environment, there is no need to move 3D data, scanned or otherwise, between different software applications. All of the work can be done in a single environment. Engineers need not waste time fixing geometry. They can focus on design instead.

Overall, incorporating Facet Modeling alongside Parametric and Direct Modeling is a considerable boon to engineers that leverage reverse engineering in their development processes. It removes much of the digital friction in the workflow, allowing engineers to focus instead on design.

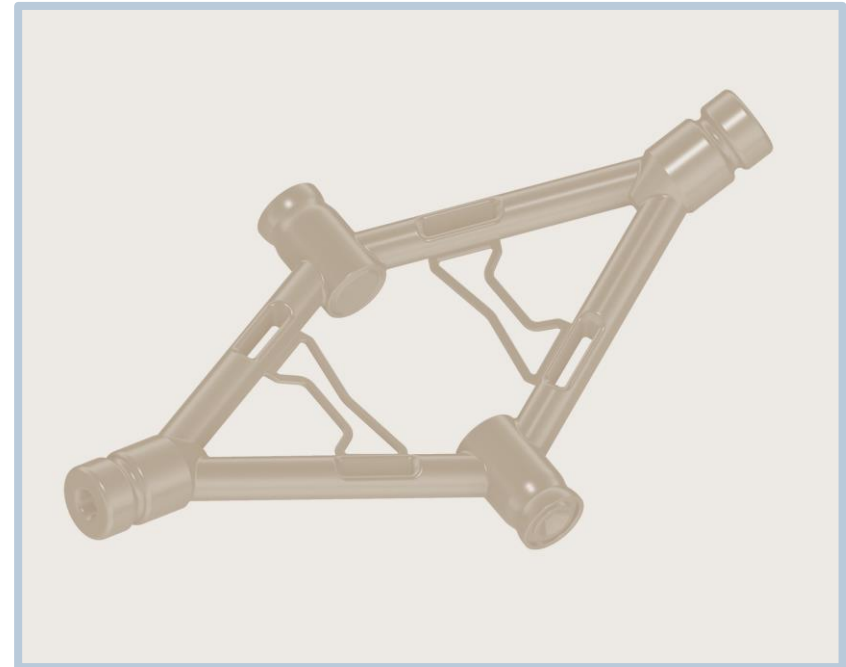

SUMMARY AND CONCLUSION

Reverse engineering is a longstanding practice in product development. Yet as design has transitioned into a series of digital workflows, the technologies used to enable reverse engineering has not evolved. As a result, significant digital friction exists in the workflows that enable the practice.

REVERSE ENGINEERING IN PRODUCT DEVELOPMENT

As a practice, reverse engineering is used in numerous stages of development. In Concept and Detailed Design, scanned items can act as the basis or context for new design ideas or detailed models. In Prototyping and Testing, reverse engineering products or components enables quick exploration and test iterations, root cause analysis, and validating other new designs. Reverse engineering plays a key role.

Scanning an item generates a point cloud of hundreds or thousands of measurements. This can be used to create solid geometry by generating planar facets between any three of the points in the cloud. The result is mesh geometry that cannot be manipulated, modified, or edited using Parametric or Direct modeling capabilities. Facet Modeling enables changes to this geometry instead.

THE TWO APPLICATION SOLUTION

Traditionally, CAD applications provided Parametric and Direct Modeling, but not Facet Modeling capabilities. In order to create a 3D model of a scanned component, engineers have turned to specialty CAD-like applications that offer Facet Modeling. This has constrained their design efforts, as no single environment has provided Parametric, Direct, and Facet Modeling, each of which is

needed to explore new design options. Furthermore, the use of two distinct and separate applications has forced engineers to translate design data from one to the other. Such data exchange often results in broken geometry that takes significant time to fix.

THE SINGLE APPLICATION SOLUTION

In the past year, some CAD applications have added Facet Modeling to their capabilities, alongside Parametric and Direct Modeling. This lets engineers transform scanned data more easily into boundary representation geometry. It lets them more readily use scanned data as context for the development of new designs. It also eliminates the need to transform and translate those models, which saves them significant time. In all, these progressive CAD applications have removed a significant amount of digital friction from the reverse engineering workflow.

FINAL TAKEAWAYS

Reverse engineering has been and continues to be a key activity in the development process. With the emergence of CAD applications that offer Parametric, Direct, and Facet Modeling, engineers can recoup their productivity and spend more time on design.

© 2017 LC-Insights LLC



Chad Jackson is an analyst, researcher and blogger with [Lifecycle Insights](#), providing insights on technologies that enable engineering, including CAD, CAE, PDM & PLM. chad.jackson@lifecycleinsights.com