



**SIEMENS**  
*Ingenuity for life*

Siemens Digital Industries Software

# Applying multi-discipline collaboration (ECAD/MCAD) to reduce program risk

## Executive summary

Technological advancements and new market demands have contributed to the exponential rise in the complexity of aircraft designs over the last decade. ECAD-MCAD automated co-design leads to increased productivity while ensuring a robust design and reducing the cost of quality. Aerospace mechanical and electrical designers are now able to synchronize their data more efficiently and collaborate more effectively on critical design items, thereby ensuring proper implementation of design intent.

Anthony Nicoli  
Director Aerospace and Defense

# The challenge: Aircraft electromechanical design

The design and manufacture of a new commercial aircraft is extremely complicated, expensive, and risky. The development can cost billions of dollars and last up to ten years before the new plane enters service. Increasing electro-mechanical complexity and density makes aircraft design especially challenging and resource intensive (figure 1). Electronics govern a majority of the critical systems in next generation planes, like flight control actuation, cabin pressurization, and wing de-icing. The computers, sensors, and wiring needed to connect and control these systems will come to dominate the interior of the airframe. Cabin amenities add even more wiring due to increasing demands for entertainment and communication systems.

Aircraft must also support extensive redundancies to prevent individual system failures from causing catastrophe. The electrical wiring and interconnect systems (EWIS) regulations, set forth by the FAA, outline standards for the design, implementation and maintenance of airplane wiring harnesses. A major component of these regulations is the physical separation and segregation of electrical wires from other systems and from other wiring. This is crucial to achieving safety and redundancy requirements in a plane, and helps prevent failures such as harness chafing, arcing, and electromagnetic interference from damaging or disrupting other systems.

Despite its difficulty, electro-mechanical design and development must adhere to strict schedules. Delays in progress can cost the company millions of dollars in extra development and follow-on effects of late entry into service. What's more, errors in design can snowball into larger problems when manufacturing begins, further jeopardizing progress. Even small inaccuracies in wire lengths or spacing between bundles can prevent the proper installation of the wire harnesses. This not only adds significant cost but also can delay delivery of aircraft to customers, affecting the company's reputation and stock price.

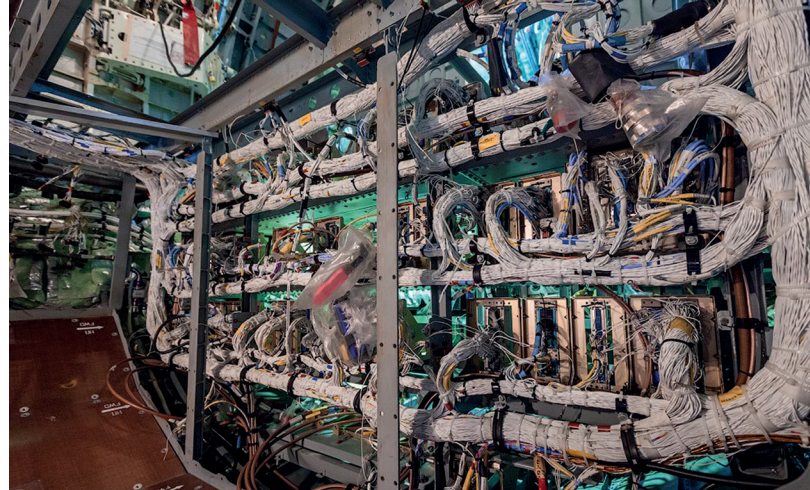

Figure 1: Modern airplanes have incredibly complex electrical wiring and interconnected systems

Additionally, aerospace companies are less able to recoup cost overruns from development problems during manufacturing. Unlike automotive manufacturers, who can amortize engineering cost over millions of vehicles, aircraft companies produce thousands of a given airplane, at most. These relatively small production numbers leave very little room for absorbing additional cost in development. As a result, there is immense pressure to proceed as smoothly as possible.

This paper discusses how an efficient electrical-mechanical CAD (ECAD-MCAD) co-design process helps design teams eliminate costly electromechanical issues during airplane design and manufacturing, maximizing early design productivity and minimizing the cost impact of follow-on change orders.

# Why co-design?

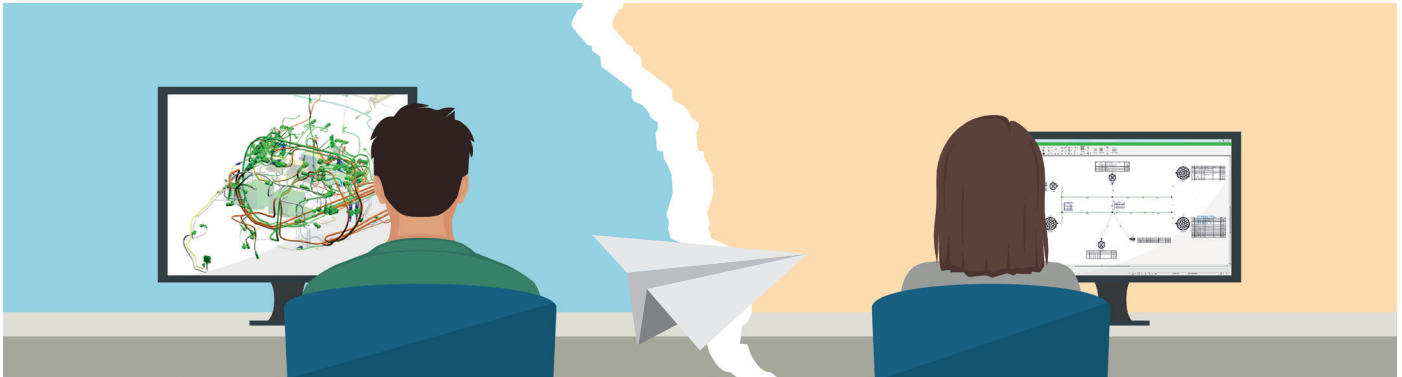

Figure 2: The traditional separation of electrical and mechanical engineers inhibits design synchronization

There is immense pressure on aircraft design teams to move quickly and hit program milestones. This can erode the motivation to perform extra analysis and validation of aircraft designs before release to initial production. Under these conditions, difficult-to-notice errors go undetected, and can result in significant problems. For example, if an aircraft manufacturer develops a military derivative of their commercial aircraft, the redesign will be completed as quickly and economically as possible. Changes that are made without proper communication between the electrical and mechanical domains can inadvertently introduce EWIS violations into the design. If these go undetected until critical design review, the manufacturer will need weeks or even months to re-design, re-verify, re-release, and then retrofit each plane under construction. Such mistakes are incredibly costly and can put programs, careers, and even companies at risk.

Given the impact of ever-increasing electro-mechanical complexity, how do companies adjust their airplane development process in order to design accurately while meeting tight timelines? The optimal strategy is to use a process that allows for the incremental and digital exchange of ECAD and MCAD design data throughout

the design process. Incremental data exchange ensures that the relevant multi-disciplinary features in the ECAD and MCAD platform representations are synchronized at each point in the design. This continual synchronization creates a steady line of communication between the electrical and mechanical engineers, increasing productivity and reducing design errors.

The potential impediments to ECAD-MCAD collaboration are numerous. First is the traditional separation that has existed between the electrical and mechanical disciplines (figure 2). Electrical and mechanical engineers typically work with completely different tool sets and have completely different vocabularies. Many times, they even reside in different physical locations.

Furthermore, mechanical and electrical CAD systems have different ways of presenting the structure of the same object. MCAD systems might represent an LRU in a physical bill of materials such as the screws, chassis, circuit boards, and connectors. However, an ECAD representation of the same module would include a functional or schematic view that transcends the physical structure of the object. Certain electrical functions can map to several different circuit boards and connectors,

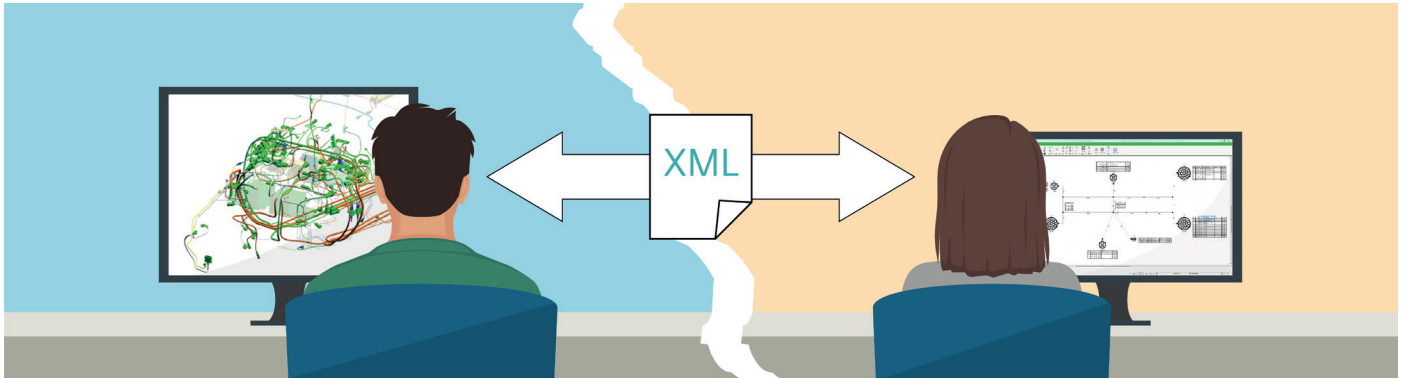

Figure 3: XML helped connect the traditionally separated ECAD and MCAD domains

making it impractical to associate a single function to a single physical part.

Because of these and other impediments, previous efforts to collaborate have met with limited success. Earlier ECAD-MCAD collaboration tools used everything from sticky notes, and email, to Excel® spreadsheets. These approaches fell far short for obvious reasons. As a result, many aerospace development teams resorted to internally developed software and processes for collaboration that they had to test and verify with each new release of the underlying ECAD and MCAD tool suites. These locally developed software and processes were costly to maintain and required dedicated in-house support.

The development of the XML file format helped resolve some of these challenges. XML is a platform-agnostic format for storing data, meaning that many different types of programs and machines, even humans, can read it. With XML, electrical and mechanical designers can directly transfer data between their respective design environments, bridging the gap that had traditionally existed between the electrical and mechanical domains (figure 3).

Because of its versatility, many companies have devised their own XML schema to enable interoperability between various software products. We developed PLMXML as a means of communicating between their MCAD tool, NX, and other applications that have adopted the format, such as the Capital electrical suite.

NX and Capital integration through PLMXML allows the ECAD and MCAD designs to synchronize as necessary, ensuring design compatibility while allowing the

designers to operate in their native environments. At a high level, the design flow between Capital and NX might look like this:

1. The ECAD designer begins by creating the wiring and connectivity layout in Capital. This layout includes key components such as wires, connectors, multi-cores, and splices. The designer then exports this wiring data to the mechanical engineer.
2. The mechanical engineer imports the PLMXML file and NX automatically links the electrical data to the 3D objects. The mechanical engineer can then route the wiring through the platform, enabling bundle diameter calculations to take place. When ready, a file containing these incremental changes is exported for review by the ECAD designer.
3. The ECAD designer then imports this data and performs a number of checks on the design. The designer can use the 3D wire lengths from NX to perform voltage drop calculations and ensure that enough space has been reserved in the mechanical design to fit the wiring bundle. Changes can be made as needed, and a new incremental file can be sent back to the mechanical engineer.

This process enables the designers to verify the design collaboratively at regular intervals, preventing spatial or electrical system violations. However, this method still requires the manual export and import of data. The ECAD and MCAD domains can be even more tightly integrated to achieve greater savings in time and cost.

# XML limitations

Linking different platforms together via XML is certainly an improvement over the old methods of transferring Excel sheets or marked-up PDF files to track changes and maintain design intent. However, because the engineers must manually export and import the XML data, after one domain completes design changes, they must wait for the other designer to review and accept or reject the proposed changes. This increases down time on a project, prolonging the development process.

This level of integration circumvents the barriers between ECAD and MCAD only partially. When proposing design changes, the ECAD and MCAD designers are doing so with only the knowledge of what the changes mean for their domain. Therefore, a designer working in the Capital environment could propose changes that would cause spatial or physical violations, and not know this until the mechanical engineer reviews and rejects the changes.

# True co-design: Cross-probing

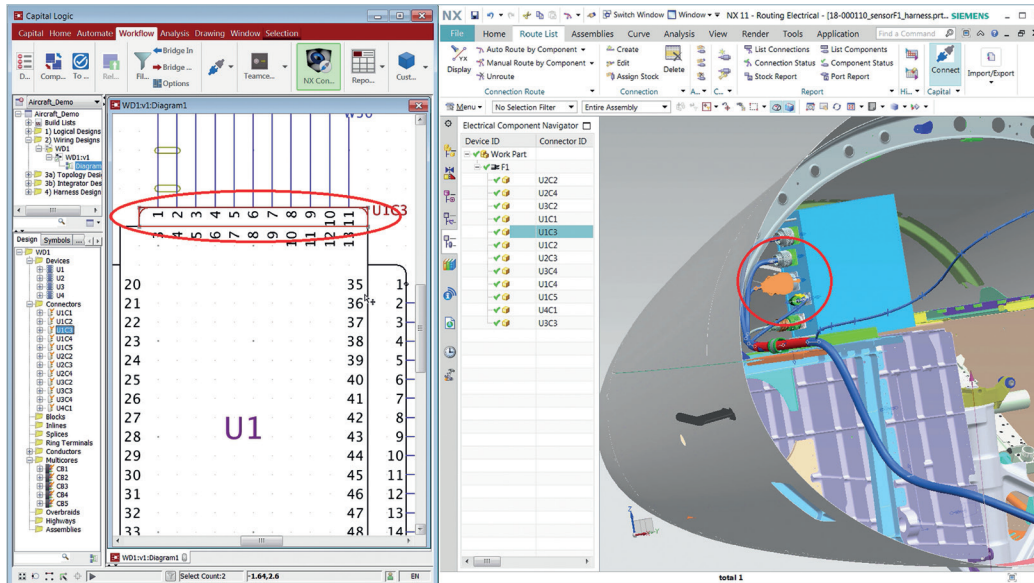

Figure 4: A connector is selected in the electrical logic design (left) and then automatically highlighted in the MCAD tool (right)

The electrical and mechanical design processes can be more connected, integrated, and collaborative than they are today. Seamless cross probing between the two domains enables closer integration and collaboration by enabling the engineers in each domain to design with contextual information from the other (figure 4).

A key feature of such integration is replacing the cumbersome file-based exchange of the XML method. With XML, integration depends on exporting a massive file of changes into a file system for other engineers to retrieve and import. Capital and NX support API level integration, where the two domains connect directly to update the design with changes or new information. Engineers no longer swap XML files but truly integrate at the data level via a robust mechanism. For instance, a Capital designer may publish a bill of materials for the wiring that NX then seamlessly consumes.

With this integration, design of the electrical system and wiring harness takes place with explicit knowledge of hazardous areas, such as severe weather and moisture prone (SWAMP) areas. Doing so allows the ECAD designer to account for the impact on the electrical performance of these areas when designing the electrical system. On the mechanical side, space reservations can be made and the severity of bends in the harness can be adjusted to account for the wiring bundles that must route through the mechanical structures. With access to this contextual information from other domains, both electrical and mechanical engineers can quickly reconcile incompatibilities between the ECAD and MCAD designs.

In a typical example, the mechanical engineer wants to make sure that the bundle containing all of the necessary wires will route through the allotted physical space. The mechanical engineer does not want to create and manage these wires in the MCAD model, as it would be too difficult and time-consuming. Instead, the electrical definition is created in Capital. The maximum allowed bundle diameter, based on various mechanical constraints, is shared with Capital. By automatically applying design rules, Capital ensures that the wire bundles, composed of synthesized or interactively routed wires, remain within the bundle diameters specified by the mechanical designer. This ensures correct by construction design and avoids costly rework.

In the last few years, the electrical and electronic content in airplanes has expanded while the space available has remained constant. The increase in in-flight entertainment systems, the introduction of in-flight wireless internet, and the move towards electrically operated systems have all increased the amount of wiring necessary to transmit data and power around the plane. Designers must contend with this increase in electrical

content while working with the same amount of physical space and maintaining the mandated system redundancy and physical separation. Cross probing and cross visualization between environments enables designers to understand wire routing in 3D space and thus determine the optimal routing.

This electronic expansion will only continue in the future. The more electric aircraft (MEA) concept posits an aircraft that will operate an increasing number of its systems electrically, eventually including the propulsion systems. Such an aircraft replaces the hydraulic, pneumatic, and mechanical operation of various systems with electrical systems. The MEA is expected to increase the efficiency and reduce the weight of the aircraft, resulting in environmental, financial, and reliability benefits. However, because its vast electrical system will govern everything from in-flight entertainment to the actuation of ailerons and landing gear, the MEA will need to possess several layers of electrical redundancy. The wire harness design will therefore be under additional scrutiny as it grows in size and function.

# Change management



Figure 5: The formboard provides a full scale drawing of the harness to aid in manufacturing

The immense complexity of modern planes results in thousands or even millions of tradeoffs and change orders, impacting cable length, type, and physical placement. A robust change management methodology is paramount to integrated electrical and mechanical aerospace design.

Mechanical design defines the bend radius constraints of the wire bundle based on its physical structure. By communicating these bend radius constraints back to Capital, the electrical engineer can use them to create the formboard upon which the wiring harness will be assembled (figure 5). With the bend constraints from MCAD, Capital can alert the formboard engineer if they are creating a model that cannot be cost-effectively manufactured.

Even after the harness design is relatively mature, late-breaking design and manufacturing changes can affect the entire system in unpredictable ways. Customer specifications and suppliers' inability to produce

necessary components can result in modifications to the design. For instance, modern aircraft are equipped with hundreds of sensors monitoring both external conditions, like weather and barometric pressure, and internal conditions, like cabin climate and fuel level. Each of these sensors connects to the wiring harness to store and communicate the information they gather. Replacing or moving any of these sensors could spawn multiple change orders for both mechanical and electrical designs that would then need to be verified for cost, weight, and functionality.

Miscalculating the length of a wire during design can prevent the connection of LRUs or other components around the plane. Once the harness is constructed wires cannot be extended to the correct length, resulting in significant rework and cost to solve the problem. Re-engineering the harness would spawn dozens of change orders that engineers must implement as quickly and accurately as possible to enable manufacturing of the plane to proceed.



The challenge of change management, therefore, is how to track ECAD-MCAD inter-domain changes quickly and efficiently. There are two major aspects of change management. First is the automatic merging of data and the clear display of changes to the designer. Capital is equipped with a robust change management tool that automatically creates a list of changes made to the design (figure 6).

From this list, the electrical engineer can choose to accept or reject each change individually, rather than as a full set of changes. The change management window in Capital is also able to live cross-probe with both the electrical and mechanical designs. As each item is selected in the change management tool, it will be automatically highlighted in either the MCAD or ECAD environments to help the engineer understand the change being proposed. The change manager can also preview a set of changes in a flattened diagram. The flattening may be 3D, orthogonal, or unfolding (figure 7).

The other critical piece is a change policy that defines whether the electrical or mechanical design is the master of the data and the direction in which changes will flow. Capital has a robust set of options that allow for the automatic control of how data is changed. Ownership over data is determined in a granular fashion so that the change policy can be tailored to individual design flows. The pieces available for selection are highly detailed, such that rules may be set for specific attributes of individual components. For example, a rule may be set that MCAD is only able to update the weight attribute of a connector, but not the electrical characteristics.

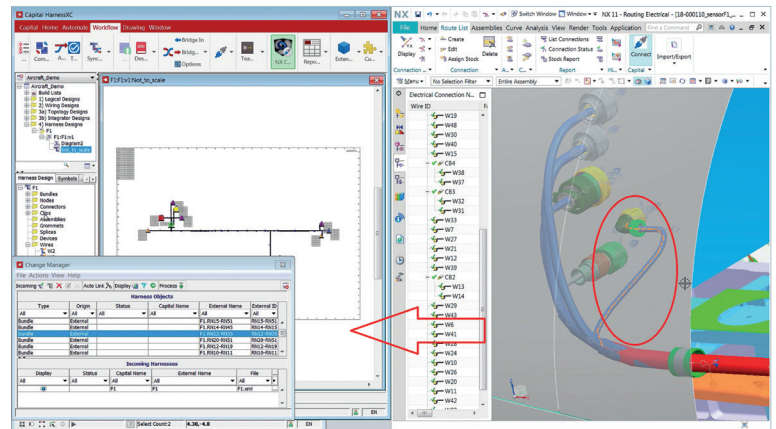

Figure 6: Incoming changes from the MCAD tool are clearly displayed for the electrical engineer to review

Variant management further complicates change management. Aircraft companies build each of their aircraft to the specifications of the customer. This is particularly true of the plane’s cabin. Different airlines will feature different entertainment options, seating configurations, and so forth. As a result, the wiring harness design of each customer’s fleet is unique. An intelligent, federated management tool and database for the harness design variants is needed. This data manager must intelligently provide mechanical and electrical engineers with up-to-date variant information relevant to their domain without forcing either discipline to adapt to the other’s database.

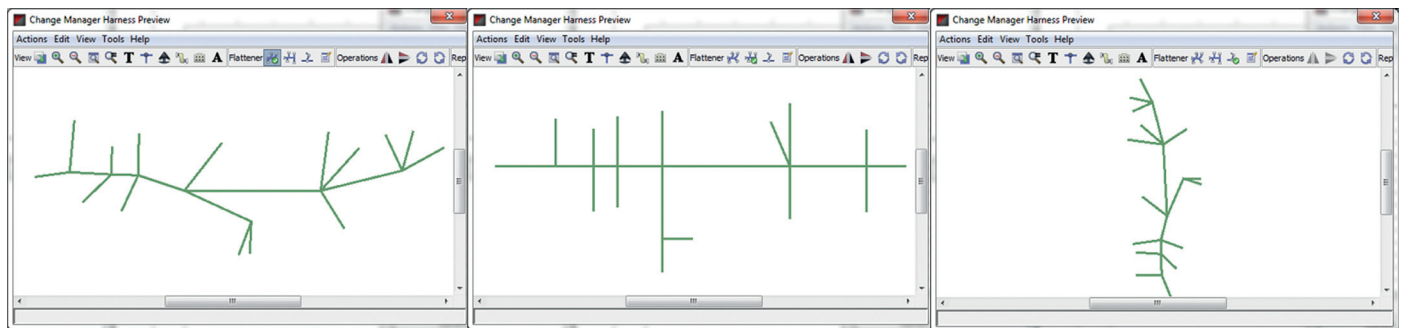

Figure 7: Capital’s change manager can preview in 3D, orthogonal, or unfolding flattening.

# Looking ahead: All electric planes and autonomous flight

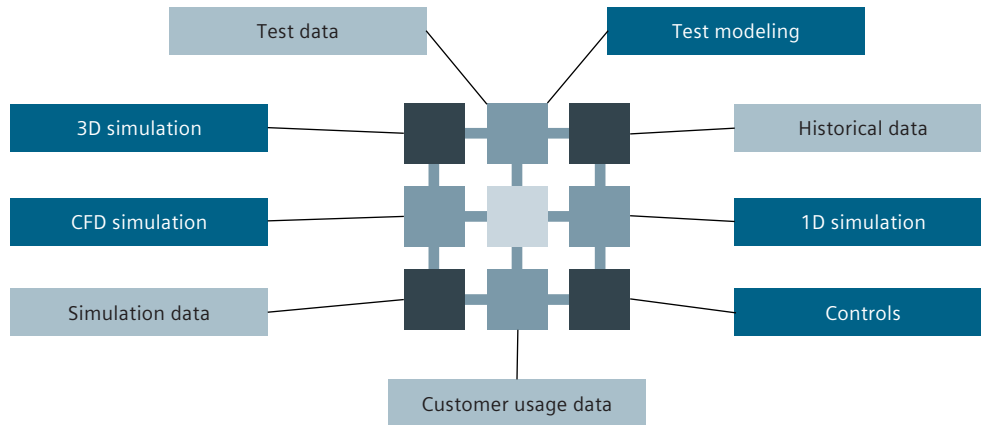

Figure 8: A model-based systems engineering approach enables advanced architectural exploration and design optimization

With advances in sensor, data processing, and machine learning technologies, fully autonomous flight is on the horizon. In the meantime, several airlines are pushing for the ability to begin single pilot operations. Single pilot operations will increase reliance on the automated systems of the aircraft for monitoring purposes. This will require significant redesign of the cockpit and underlying systems. Gauges and monitors will have to be oriented so that one pilot can easily locate and read key flight information. The single pilot will also need to be able to reach and operate all switches, buttons, and dials on the flight deck. As changes to the human-machine interface are implemented, the electrical wiring connecting those interfaces must also change. ECAD-MCAD integration will enable designers to optimize the cockpit of commercial aircraft for single pilot operations while ensuring the electrical system meets heightened standards for safety and reliability.

As the integration between ECAD and MCAD domains increases, the ECAD-MCAD design flow will approach true model-based systems engineering. This will enable engineers to perform powerful architectural exploration at the very beginning of the design process. Today, Capital is able to implement trade studies on the functional and systems architecture and then optimize across the platform. Designers will be able to examine dozens of potential variations, layouts, and configurations all while running hundreds of different analyses to determine the best possible configuration (Figure 8).

# On time and on budget

Technological advancements and new market demands have contributed to the exponential rise in the complexity of aircraft designs over the last decade. ECAD-MCAD automated co-design leads to increased productivity while ensuring a robust design and reducing the cost of quality. Aerospace mechanical and electrical designers are now able to synchronize their data more efficiently and collaborate more effectively on critical design items, thereby ensuring proper implementation of design intent.

The possibilities for model-based design exploration are even more exciting. With automated wire harness design processes, engineers will generate alternative wiring solutions that conform to hundreds of design constraints, and do so in minutes. As a result, they will explore dozens of alternative wiring configurations by varying the constraints and looking at the effect upon weight, cost and performance.

During design, seamless cross-probing between the electrical and mechanical environments helps designers understand their counterpart's domain and provides ongoing cross-domain decision assessment. This enables inconsistencies to be identified and resolved early, reducing costly design iterations. ECAD-MCAD co-design, with rich change management support, provides a key enabler for design teams to reach program milestones, ensuring the project proceeds on schedule, while minimizing cost.

## Siemens Digital Industries Software

### Headquarters

Granite Park One  
5800 Granite Parkway  
Suite 600  
Plano, TX 75024  
USA  
+1 972 987 3000

### Americas

Granite Park One  
5800 Granite Parkway  
Suite 600  
Plano, TX 75024  
USA  
+1 314 264 8499

### Europe

Stephenson House  
Sir William Siemens Square  
Frimley, Camberley  
Surrey, GU16 8QD  
+44 (0) 1276 413200

### Asia-Pacific

Unit 901-902, 9/F  
Tower B, Manulife Financial Centre  
223-231 Wai Yip Street, Kwun Tong  
Kowloon, Hong Kong  
+852 2230 3333

## About Siemens Digital Industries Software

Siemens Digital Industries Software, a business unit of Siemens Digital Industries, is a leading global provider of software solutions to drive the digital transformation of industry, creating new opportunities for manufacturers to realize innovation. With headquarters in Plano, Texas, and over 140,000 customers worldwide, we work with companies of all sizes to transform the way ideas come to life, the way products are realized, and the way products and assets in operation are used and understood. For more information on our products and services, visit [siemens.com/plm](https://www.siemens.com/plm).

## [siemens.com/plm](https://www.siemens.com/plm)

© 2019 Siemens Product Lifecycle Management Software Inc. Siemens and the Siemens logo are registered trademarks of Siemens AG. Femap, HEEDS, Simcenter, Simcenter 3D, Simcenter Amesim, Simcenter FLOEFD, Simcenter Flomaster, Simcenter Flotherm, Simcenter MAGNET, Simcenter Motorsolve, Simcenter Samcef, Simcenter SCADAS, Simcenter STAR-CCM+, Simcenter Soundbrush, Simcenter Sound Camera, Simcenter Testlab, Simcenter Testxpress and STAR-CD are trademarks or registered trademarks of Siemens Product Lifecycle Management Software Inc. or its subsidiaries or affiliates in the United States and in other countries. All other trademarks, registered trademarks or service marks belong to their respective holders.  
77780-C7 4/19 Y