



SIEMENS

Ingenuity for life



Siemens Digital Industries Software



Avoiding judder in automatic transmissions

Engine manufacturers use downsizing strategies and higher torques at lower engine speeds to improve fuel economy. This approach also affects transmissions. Siemens Digital Industries Software has broad experience with resolving judder issues and frontloading design decisions that can help address future adaptations or models. This white paper discusses how to analyze the use of the torque converter and the lock-up clutch at an early stage to optimize performance and reduce losses.

Executive summary

During the engagement of the lock-up clutch in automatic transmissions, judder may occur. Predicting the occurrence of this phenomenon is essential in the development process of a new transmission. The recent downsizing trend leads to the early closing of the lock-up clutch and the use of higher torques at lower engine speeds. This is when the self-induced judder occurs.

The influence of the clutch friction characteristics has been evaluated in detail. In addition, the entire drive's damping characteristics considerably influence the system's stability margin. Consequently, transmission manufacturers first focus on the transmission and then on the damping characteristics of components, such as the lock-up damper and the torque converter.

After integrating the transmission in a vehicle model, the complete vehicle needs to be analyzed. This gives the transmission manufacturer the opportunity to prevent potential transmission judder problems in different types of cars as early as possible in the design cycle.

Once the full-vehicle model is available, a sensitivity study is performed. This third step will pinpoint the powertrain mode that is likely to cause judder, as well as the component that contributes most to the modal damping. This component will then be first in line to be adapted to increase the stability margin. Since it is a full-system analysis, the transmission manufacturer is able to check on other components that may cause judder (for example, drive shafts and tires).

Siemens Digital Industries Software has vast experience with resolving judder issues and frontloading design decisions for future adaptations or models. The expertise and application knowledge of Simcenter Engineering services help transmission manufacturers optimize performance and reduce losses by analyzing the use of the torque converter and the lock-up clutch at an early stage. In addition to traditional test-based diagnosis methods, such as transfer path analysis (TPA) and operational deflection shapes (ODS) analysis, Simcenter Engineering services develop 1D and/or 3D simulation models with load-predictive capabilities to better understand the reasons behind judder.

Self-excited vibrations

Engaging the clutch can be responsible for drivetrain oscillations. When the clutch is engaged, torsional vibrations are transmitted via suspension and engine mounts, leading to acceleration of the vehicle body, which can be felt by the driver. These clutch-induced drivetrain oscillations are called clutch judder. Depending on how it is caused, judder is generally classified as self-excited on the one hand, and forced excited on the other. Figure 1 shows the classical textbook model of a friction oscillator that becomes unstable at velocities in which the friction curve has a negative slope. Self-excited vibrations typically occur in systems in which considerable forces are transferred through friction, as is the case with clutches.

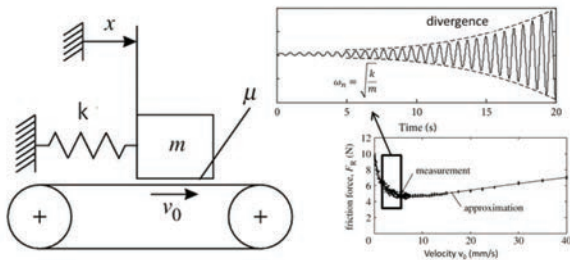

Figure 1: Judder measured at the transmission output shaft. We will now describe the typical process for analyzing the use of the torque converter and the lock-up clutch at an early stage.

1. Data acquisition

Noise, vibration and harshness-related measurements and data are acquired in order to conduct TPA and ODS analyses. These will give an accurate description of the as-is state of a vehicle. Traditional noise, vibration and harshness (NVH) data are acquired simultaneously with detailed measurements of torque, rotations-per-minute fluctuations and combustion pressure. The latter enables engineers to define the input and validation signals for the simulation models.

2. Transmission modeling

By using Simcenter™ Amesim™ software, Simcenter Engineering experts create a virtual transmission model. Figure 2 shows an example of such a model. The essential parts that need to be modeled for simulating judder are:

- Internal transmission parts
- Torque converter
- Lock-up clutch
- Lock-up clutch control

Internal transmission parts

When modeling the internal transmission parts, emphasis is put on the correct implementation of the gear stages using clutches and brakes. Such a focus allows simulation of the gearshifts during a run-up simulation. An accurate inertia representation is required in order to ascertain the powertrain's modal behavior.

Torque converter

The two typical curves, displaying the torque ratio (TR) and the capacity factor (K) as functions of the speed ratio (SR), determine the torque converter's characteristics. For the judder analysis, especially the capacity factor plays an important role as it determines the torque converter's equivalent damping, which depends to a considerable degree on temperature.

Lock-up clutch

The lock-up clutch is, by definition, the most important factor for lock-up judder. This is not only the case due to its friction characteristics, but also because it is attached to the lock-up damper, which has features that are especially crucial for the judder analysis. It is important to precisely model these damping characteristics (hysteresis, viscous damping, etc.) because this component can provide the positive damping that is needed to counter the negative damping caused by the friction characteristics.

Lock-up clutch control

Even if the clutch is designed perfectly, poor control software or hardware design can still cause instability. In this case, so-called control judder occurs. Designing an anti-judder control is an option here. However, this task is not always feasible, especially at higher frequencies. There will certainly be considerable delays in the hydraulic system when the transmission fluid is cold, thus limiting the controller's practical bandwidth. All models that have been described previously allow for an accurate transmission simulation.

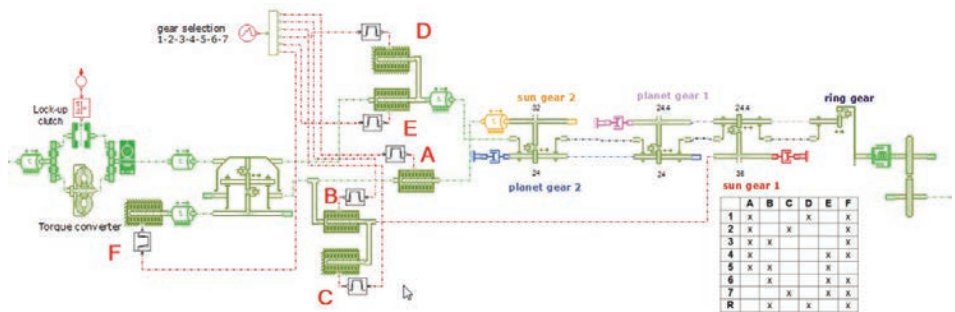

Figure 2: Example of a transmission simulation model.

3. Full vehicle modeling

Even when the transmission has not caused any judder on the test bench, it can still occur once the transmission has been installed in the vehicle. The vehicle's characteristics, such as driveshaft stiffness or tire damping, also determine the powertrain's resonance frequencies and damping. In order to forestall potential judder problems at an early development stage, full-vehicle simulations are absolutely necessary. In order to do that, the model from the previous step is extended to an engine model and a vehicle model.

Engine model

The engine model in Simcenter Amesim for analyzing judder is typically comprised of a map characterizing the torque as a function of engine speed and throttle. That is sufficient to perform several drive-cycle simulations. For self-excited judder, there is no particular need to accurately describe the torque fluctuations. The negative system damping will induce the judder, so there is no need for external excitations such as the engine harmonics.

Vehicle model

The vehicle model has to supply the correct impedance and damping to the transmission. The impedance is typically determined by the driveshaft's stiffness. Other important parameters include wheel inertia, tire stiffness and damping.

4. Sensitivity study

As mentioned above, the clutch friction characteristics influence the judder. In addition, the different driveline components' damping coefficients play a vital role as well. The simulation model has various components that include damping, such as the lock-up clutch, lock-up damper and tires.

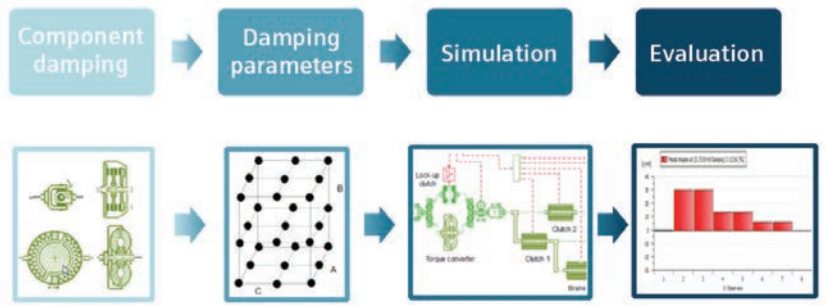

Figure 4: Process of sensitivity study.

Moreover, losses occur in the prop shaft, the differential and internal gears of the transmission. Quantifying the exact contribution of every driveline component to a particular driveline mode's total modal damping is especially significant from an engineering point of view since this information facilitates an accurate assessment of how much any contributor damps in each mode. This knowledge is not only crucial for adequate troubleshooting, but is also highly valuable in the early development phase.

The relevant contribution to damping is assessed as follows:

1. Put all damping in the model to zero
2. Attribute to one component its nominal damping
3. Run the simulation and linearize the system at a certain working point
4. Extract the eigenmodes and modal damping
5. Repeat previous steps for all components

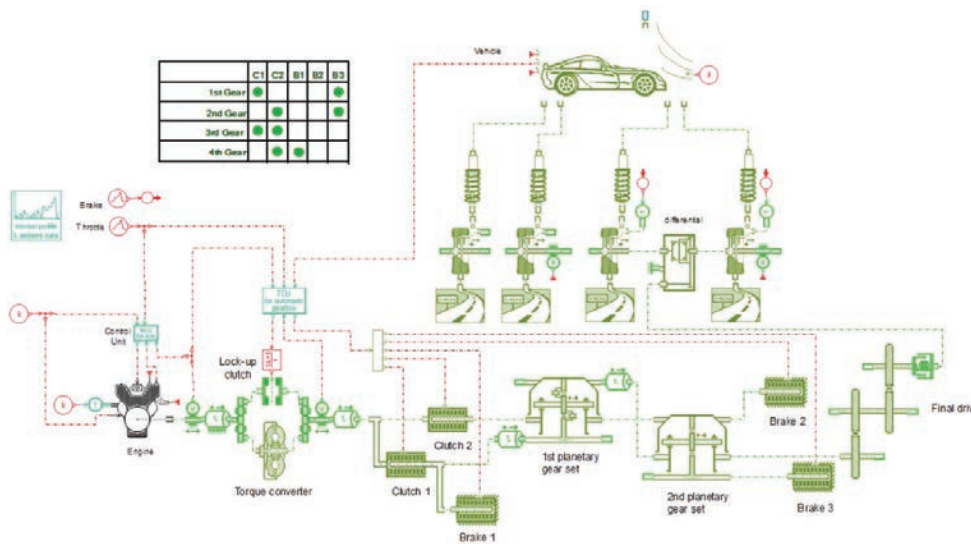

Figure 3: Example of a full-vehicle simulation model.

Conclusion

Transmission manufacturers need to be able to forestall judder problems as early as possible in the development phase. Simcenter Engineering enables such frontloading by using a four-step approach to optimize the transmission adjustment. After the necessary data is acquired, the transmission model is designed and validated. This model is extended by an engine and vehicle model to enable a full-vehicle analysis. Finally, a sensitivity study enables the engineer to pinpoint the components that damp the best. Thanks to this approach, engineers can immediately focus on the relevant parts.

References

1. Albers, A.; Stier, C.: "Analysis of Geometrical Deviations in Clutch Systems and Their Interdependencies in Relation to the Excitation of Judder Vibrations." Fisita World Automotive Congress, Budapest, Hungary, 2010
2. Krüger, A.: "Clutch judder – Causes, Effects and Countermeasures." Karlsruhe Institute of Technology, Karlsruhe, Germany, 2003
3. Albers, A.; Meid, M.; Ott, S.: "Avoiding Clutch Excited Judder by Using an Active Clamping Force Control." International Conference on Noise and Vibration Engineering (ISMA) 2010
4. Phillips, A.; Bai, S.: "Smooth Launch Control of an Integrated Friction Launch Automatic Transmission." Fisita World Automotive Congress, Yokohama, Japan, 2006
5. Lau, J. M. W.; Deblauwe, F.: "Advanced FRF Based Determination of Structural Inertia Properties." Society of Automotive Engineers (SAE) 2007

Siemens Digital Industries Software

Headquarters

Granite Park One
5800 Granite Parkway
Suite 600
Plano, TX 75024
USA
+1 972 987 3000

Americas

Granite Park One
5800 Granite Parkway
Suite 600
Plano, TX 75024
USA
+1 314 264 8499

Europe

Stephenson House
Sir William Siemens Square
Frimley, Camberley
Surrey, GU16 8QD
+44 (0) 1276 413200

Asia-Pacific

Unit 901-902, 9/F
Tower B, Manulife Financial Centre
223-231 Wai Yip Street, Kwun Tong
Kowloon, Hong Kong
+852 2230 3333

About Siemens Digital Industries Software

Siemens Digital Industries Software is driving transformation to enable a digital enterprise where engineering, manufacturing and electronics design meet tomorrow. Our solutions help companies of all sizes create and leverage digital twins that provide organizations with new insights, opportunities and levels of automation to drive innovation. For more information on Siemens Digital Industries Software products and services, visit [siemens.com/software](https://www.siemens.com/software) or follow us on [LinkedIn](#), [Twitter](#), [Facebook](#) and [Instagram](#). Siemens Digital Industries Software – Where today meets tomorrow.

[siemens.com/software](https://www.siemens.com/software)

© Siemens 2016. A list of relevant Siemens trademarks can be found [here](#). Other trademarks belong to their respective owners.
53142-C13 9/16 A