

Online-Seminar

Additive Manufacturing mit Werkzeugmaschinen & Robotern

Michael Meng & Helmut Zeyn

It's time to rethink

EVERYTHING

Industrialisierung der Additiven Fertigung

Unterstützte Druck-Technologien

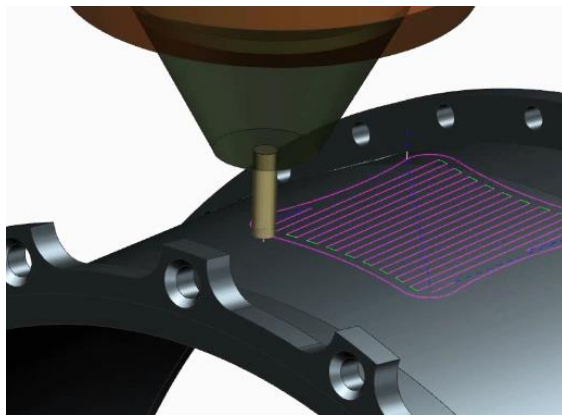

Hybrid additive
Directed energy
deposition

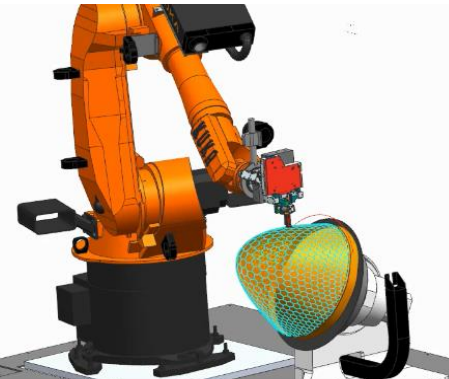

Multi-axis
Fused deposition
modeling



Powder bed fusion
material

DMG MORI
GEFERTEC

▲ Product Id	◆ Product Type	◆ Product Name
NX30629	Product	NX CAM UNIVERSAL URSCRIPT Posting Add-On
NX30641	Product	NX CAM RMR_SINUMERIK POSTING ADD-ON
NX30642	Product	NX CAM ABB Rapid Posting Add-On
NX30643	Product	NX CAM Fanuc RJ Posting Add-On
NX30644	Product	NX CAM Kuka KRL Posting Add-On
NX30647	Product	NX CAM Yaskawa Inform Posting Module Add-On
NX30648	Product	NX CAM STAUBLI VAL Posting Add-On
NX30649	Product	NX CAM NACHI SLIM Posting Add-On
NX30660	Product	NX CAM KAWASAKI AS Posting Add-On

Bauraten vs. Auflösung

(Beispiel Metall)

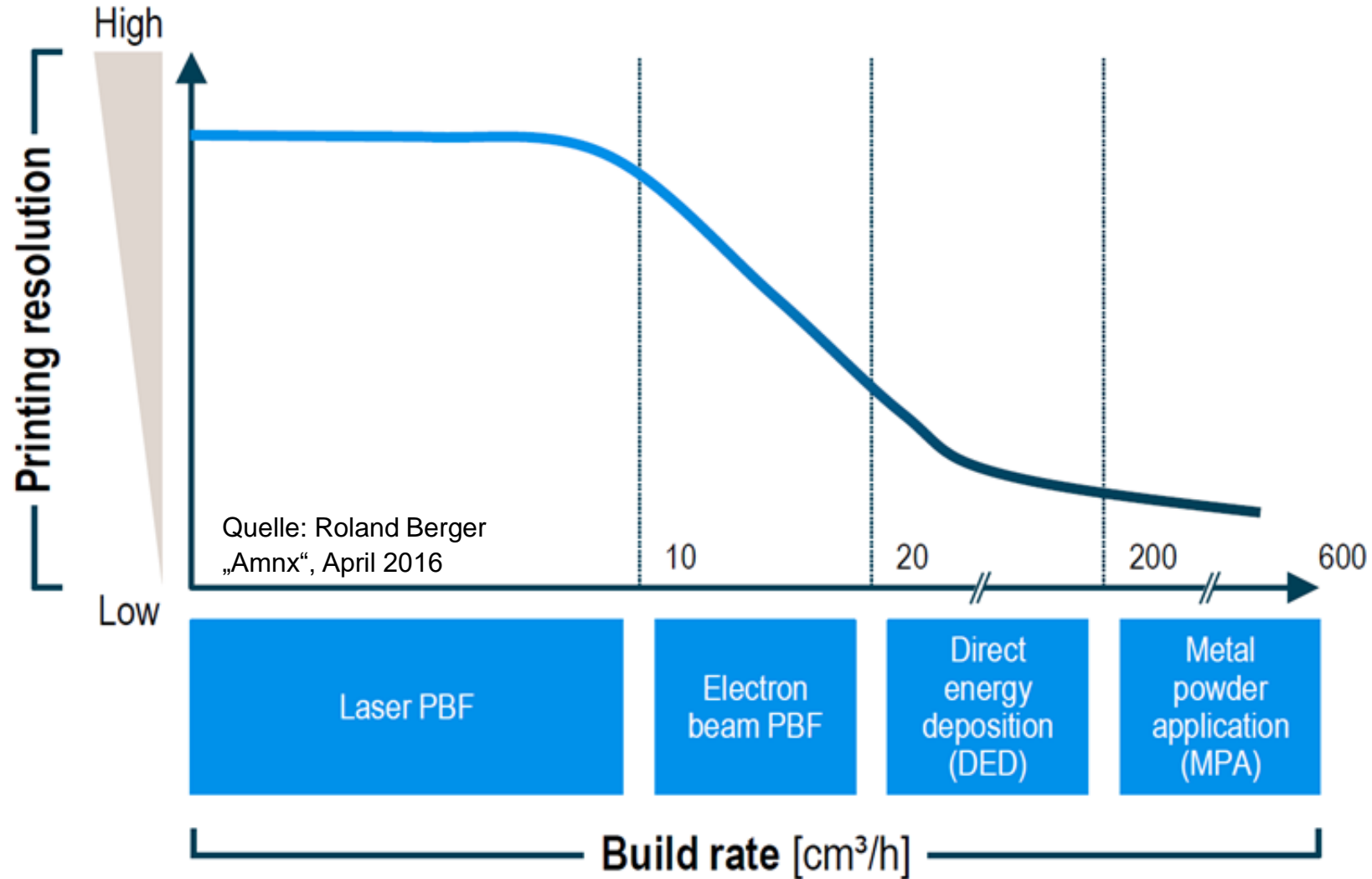

Laser / Schweisskopf

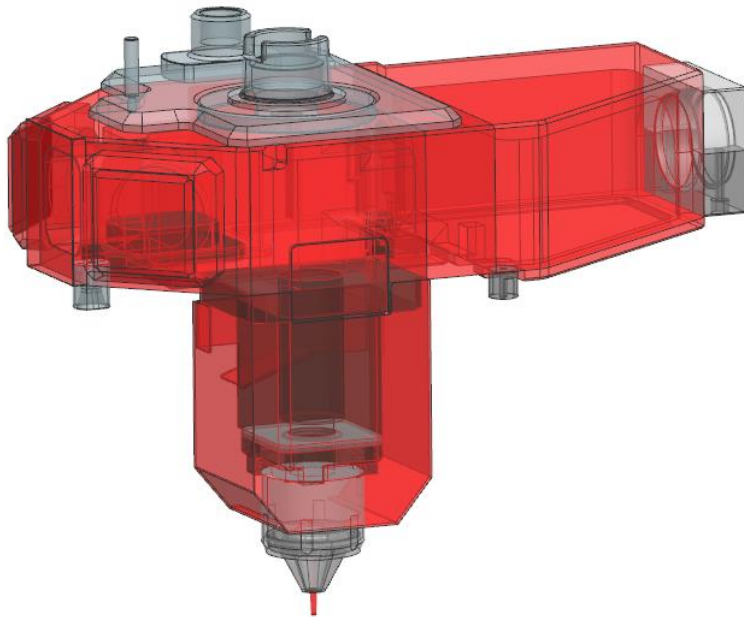

Laser Tool

Tool Holder

Legend

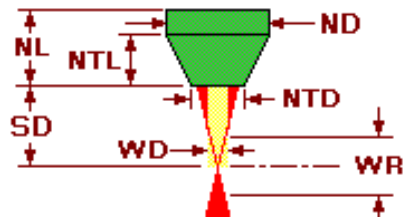

Beam Properties

(SD) Standoff Distance	14.0000
(WD) Working Diameter	3.0000
(WR) Working Range	4.0000
Minimum Power	200.0000
Maximum Power	600.0000

Nozzle Dimensions

(ND) Nozzle Diameter	34.0000
(NL) Nozzle Length	22.0000
(NTD) Nozzle Tip Diameter	12.7000
(NTL) Nozzle Taper Length	19.8000

Library Class Selection

Class to Search

- Tool
 - + Milling
 - + Drilling
 - + Turning
 - + Solid
 - Wire EDM
 - Wire
 - Laser
 - Trimming Laser
 - Deposition Laser
 - Robotic
 - End Effector (End Mill based)
 - End Effector (Ball Mill based)
 - Deposition
 - FDM Extruder
 - Deposition Laser
 - Wire Extruder

Extruder Düse

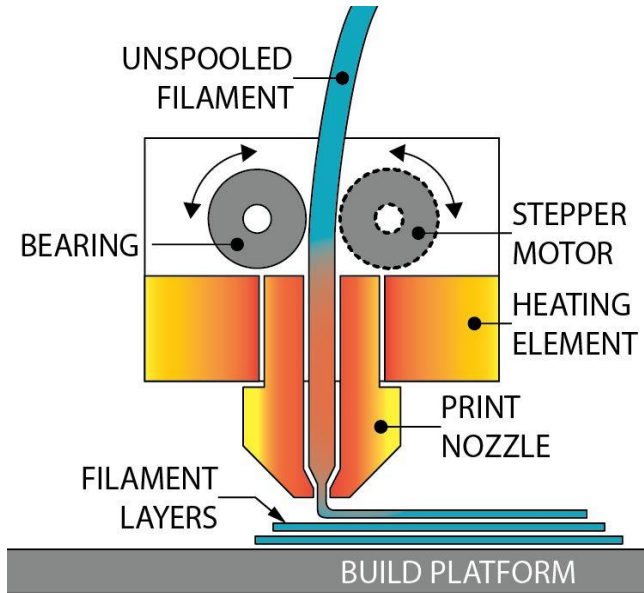

FDM EXTRUDER ASSEMBLY

FDM Extruder
✕

Tool
Holder

Legend

Extruder Properties

(SD) Standoff Distance	4.0000
(ED) Extrusion Diameter	1.0000

Tip Dimensions

(TD) Tip Diameter	34.0000
(TL) Tip Length	22.0000
(TOD) Tip Outside Diameter	12.7000
(TTL) Tip Taper Length	19.8000

Extrusion Settings

Minimum Bead Width	0.6000
Maximum Bead Width	1.4000
Minimum Bead Height	0.5000
Maximum Bead Height	1.5000
Minimum Extrusion Rate (mm ³ /s)	100.0000
Maximum Extrusion Rate (mm ³ /s)	200.0000

Library Class Selection
✕

Class to Search

Tool

- + Milling
- + Drilling
- + Turning
- + Solid
- Wire EDM
 - Wire
- Laser
 - Trimming Laser
 - Deposition Laser
- Robotic
 - End Effector (End Mill based)
 - End Effector (Ball Mill based)
- Deposition
 - FDM Extruder
 - Deposition Laser
 - Wire Extruder

Inkl. Hybrid Manufacturing

SIEMENS
Ingenuity for life

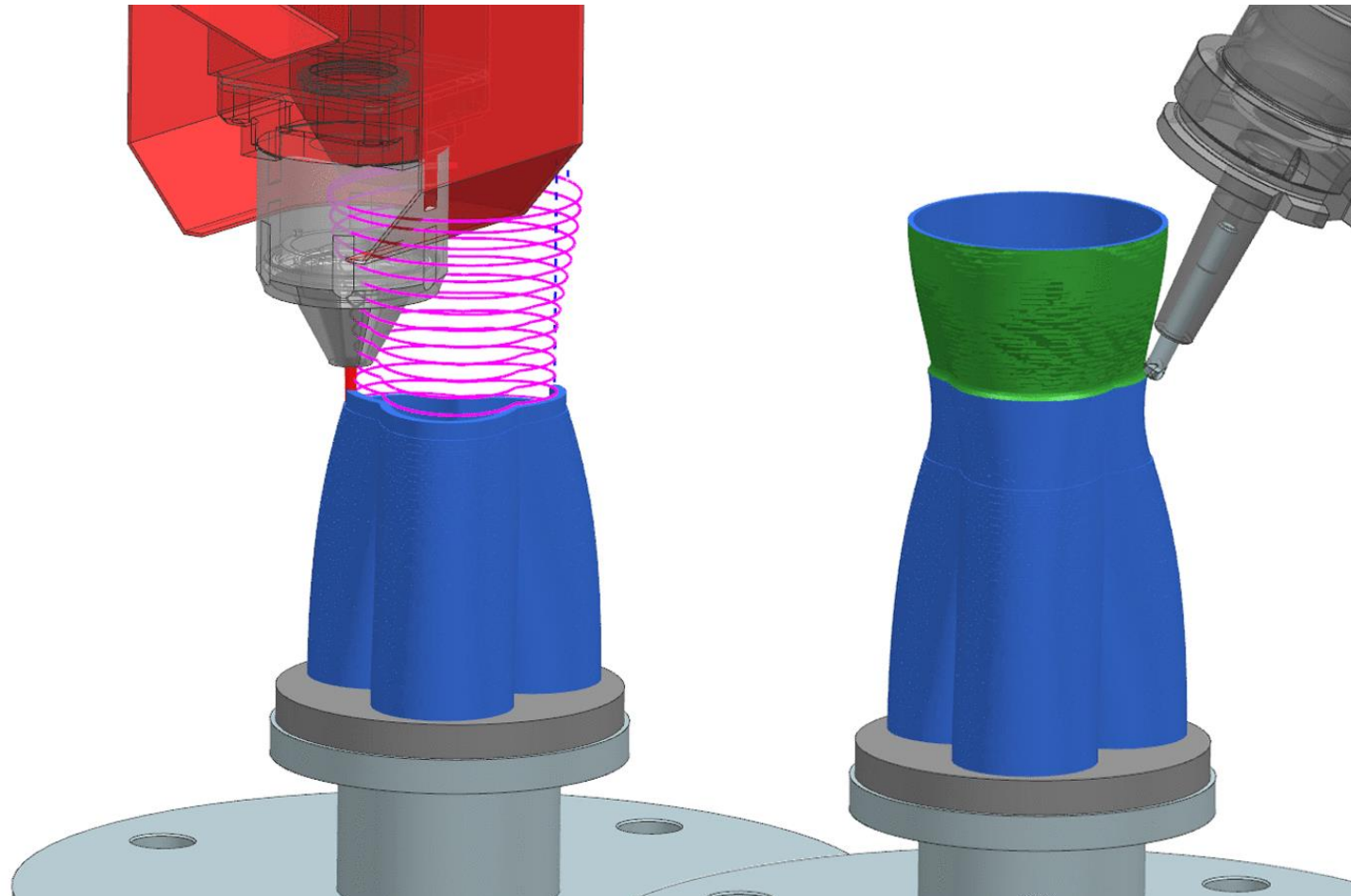

Multi-Axis Deposition – The 5 Axis platform for additive



The multi-axis deposition package is not a dedicated thermoplastic or Arc Welding or Wire Fed deposition package, it is rather a 5 axis additive platform that will help OEM developing their 5 axis deposition solution.



NXOpen API

Use API to optimize path, add process knowledge and pattern

```

While index <= thePath.NumberOfToolpathEvents
  If thePath.IsToolpathEventAMotion(index, motionType, moti

  Dim MotionTypeStr As String = [Enum].GetName(GetType(
  Dim motionShapeStr As String = [Enum].GetName(GetType(
  lw.WriteLine(" Item [" & index & "]")
  lw.WriteLine(" Motion Type =" & MotionTypeStr)
  lw.WriteLine(" Motion Shape =" & motionShapeStr)

  Select Case motionShape
  Case CamPathMotionShapeType.Linear
    'Get the linear motion
    Dim lMotionData As CAM.PathLinearMotion
    lMotionData = thePath.GetLinearMotion(index)
  
```

```

N58 CYCLE832(_camtolerance,_OFF,1)
N60 G500
N62 M52 ; Vibrator ON
N64 G700
N66 ;Atrans z=LayerOffset ; Ar
N68 G40 G0 PTP X203.128442 Y-135.10000
N70 X203.411536 Y-135.100000 Z71.49888
N72 G17 G94 G1 G90 CP X203.392741 Y-1
N74 X203.324226 Y-135.100000 Z71.2987
N76 X203.230430 Y-135.100000 Z71.2353
N78 X203.125801 Y-135.100000 Z71.1915
N80 X203.016359 Y-135.100000 Z71.1615
NR2 X202.904643 Y-135.100000 Z71.1414
  
```

Post-Processor

Create dedicate processor to control the deposition device

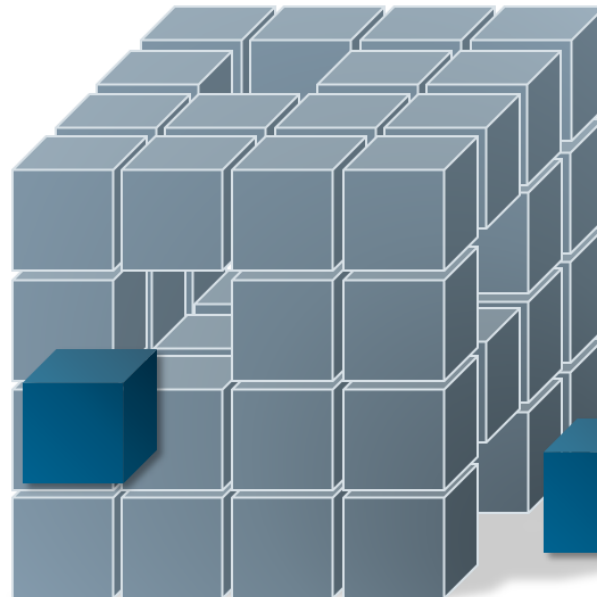

Machine Kit

Create accurate machine representation to visualize deposition process

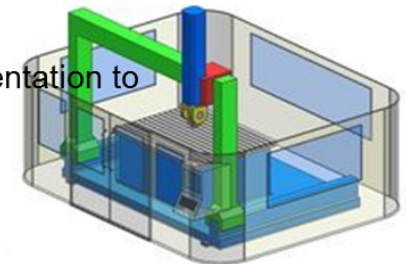

UDE

Create dedicated UDE to enrich the operation with dedicate process parameters

Dual Powder Feed Parameters	
Powder Feed 1 (mV)	400
Gas Feed 1 (mV)	600
Stirrer Speed 1 (mV)	500
Powder Feed 2 (mV)	0

Additive Geometrie Objekte

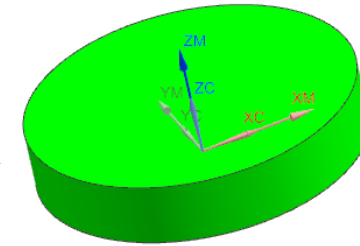
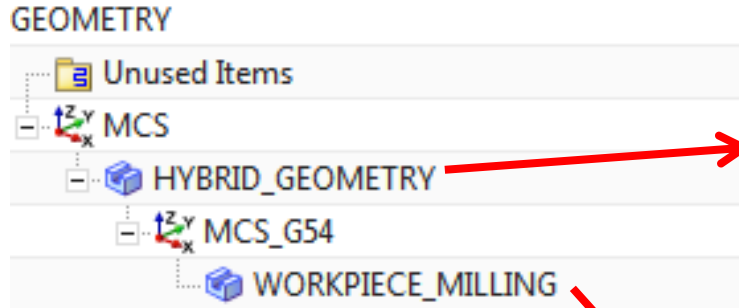

Initial Workpiece

Additive operations will go under the "HYBRID_GEOMETRY" group, as well as subtractive operations that work on the additive feature (truing up a surface before the next additive operation, for example)

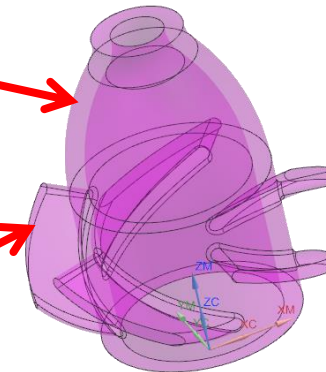

AM Raw Material

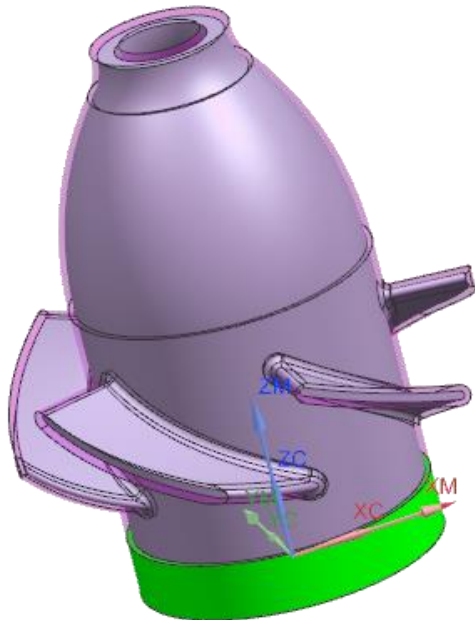

Finished Part Geometry

Subtractive operations on the finished part geometry will go under the "WORKPIECE" group (note that it is a milling group here, but there may be a turning geometry group on machines that support it)

Siemens ist einer der weltweit größten Anwender in 3D Druck

SIEMENS
Ingenuity for Life

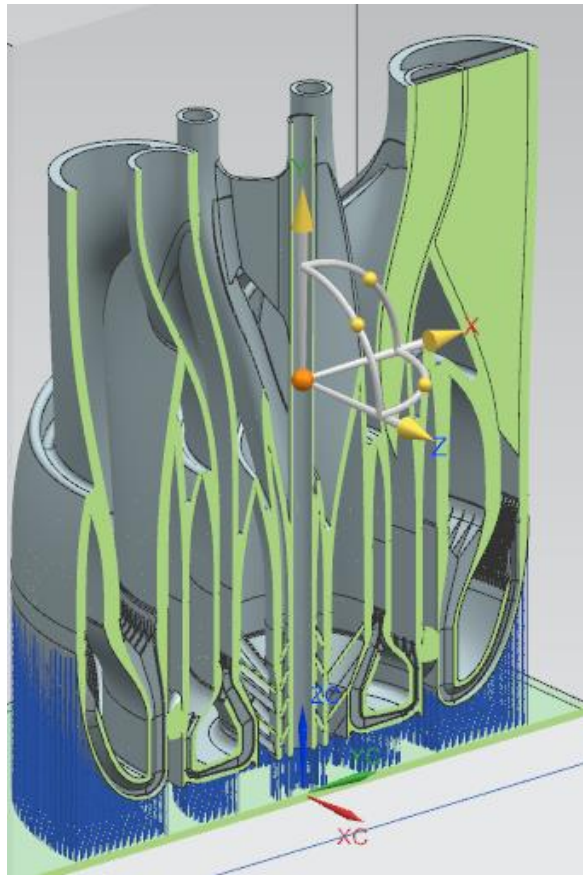

purmundus
challenge 2018
3rd prize

Jury:
„High efficient complexity of geometry“

Unrestricted © Siemens 2019

Page 10

Siemens is industrializing additive manufacturing

SIEMENS
Ingenuity for Life



Materials Solutions
A Siemens Business

Unrestricted © Siemens AG 2017
Page 4 2017.MM.DD

Siemens PLM Software

Fully operational serial production utilizing a digital end-to-end software chain has proven that industrialization of AM works

SIEMENS
Ingenuity for Life



Unrestricted © Siemens AG 2017
Page 5 2017.MM.DD

Siemens PLM Software

Siemens PLM Software

Consulting Module

Kombinierbar nach Ihren Bedürfnissen

Modular Consulting
portfolio

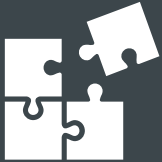



Key success
factors





Understand and ideate



- AM Awareness 
- Sense of Urgency 
- AM Vision 



Define and pilot



- Value Proposition 
- AM Parts Feasibility 
- AM Process Development 



Monetize



- Make-or-Buy & Value Stream 
- AM Business Models & Ecosystems 

Scale



- R&D Efficiency 
- AM Production Requirements 
- Production Planning 

Digitize



- Solution Landscape 
- AM Data Management 

Siemens is a world class AM user with long year experience

Siemens has excellent know-how in AM processes and materials

Siemens is the leading provider in industrialization of AM – from design to production

Additive Manufacturing Experience Center Erlangen

SIEMENS
Ingenuity for life





SIEMENS
Ingenuity for life

Michael Meng
Helmut Zeyn

