

# Thriving in a 2D to 3D to 2D world

## White Paper

Accelerate your move to 3D and unlock your design teams' true potential with the right technology. This white paper outlines how to best leverage both existing 2D drawings and design practices and utilize them in a 3D design process.

[www.siemens.com/plm](http://www.siemens.com/plm)

# Contents

<b>Executive summary</b> .....	<b>3</b>
<b>Introduction</b> .....	<b>4</b>
<b>Use 2D where it makes sense</b> .....	<b>5</b>
Creating 2D layouts .....	5
Optimizing 2D drawings .....	5
<b>Leveraging 2D into 3D design</b> .....	<b>6</b>
Creating 3D parts from 2D drawings.....	6
Define the parts list before 3D.....	6
Using 2D layouts to drive 3D assemblies .....	7
<b>3D with the simplicity of 2D</b> .....	<b>8</b>
3D model creation .....	8
3D editing .....	9
Handing imported 3D models.....	9
<b>Getting 2D from 3D</b> .....	<b>10</b>
You can get there from here .....	10
Making drawing refinements.....	10
<b>Conclusion</b> .....	<b>11</b>
<b>Further reading</b> .....	<b>12</b>

# Executive summary

Companies using 2D CAD follow a common path to 3D: use 2D while learning 3D, integrate 2D into 3D and phase out 2D except for the tasks for which it is best suited, such as schematic, layout and 2D drawing production. The challenge is how to adopt and integrate 2D into the 3D design process. Designing with 3D offers significant productivity gains, but the steep learning curve inherent in the need to preplan history based design is often barriers to entry.

This whitepaper discusses the capabilities of Solid Edge® software with synchronous technology and how it

accelerates adoption by leveraging 2D drawings and design methods. Users can create and optimize layouts in 2D, but later them use in 3D. Both 3D design and editing can utilize similar 2D concepts and 2D drawings be generated of the 3D models, providing comprehensive design capabilities. Because this design technology is feature-based and history-free, it is similar to the way that 2D systems work accelerating 2D to 3D to 2D.

# Introduction

Most companies see the need to move to 3D, but do not want to abandon their 2D skills and drawings. Without the ability to leverage both in 3D, users are left with a tough challenge.

The power of 3D CAD is known, but how to best adopt and utilize 2D isn't clear. Complete abandonment of 2D isn't realistic because 2D is still very capable for schematic and layout construction, while required for drawing generation. There needs to be a system that offers both a path to 3D and continued 2D use in a single system.

According to the Aberdeen Group's findings, most organizations mix 2D and 3D during the transition.

This white paper looks at how engineers can best make use of 2D, minimize the change during the move to 3D and leverage what they have and know afterwards.

This white paper discusses the key uses of 2D in a 3D design environment, how to best leverage 2D drawings and design concepts into 3D, and why 3D is the fastest way to 2D drawings. In essence, it describes the complete process in 2D to 3D and back to 2D.

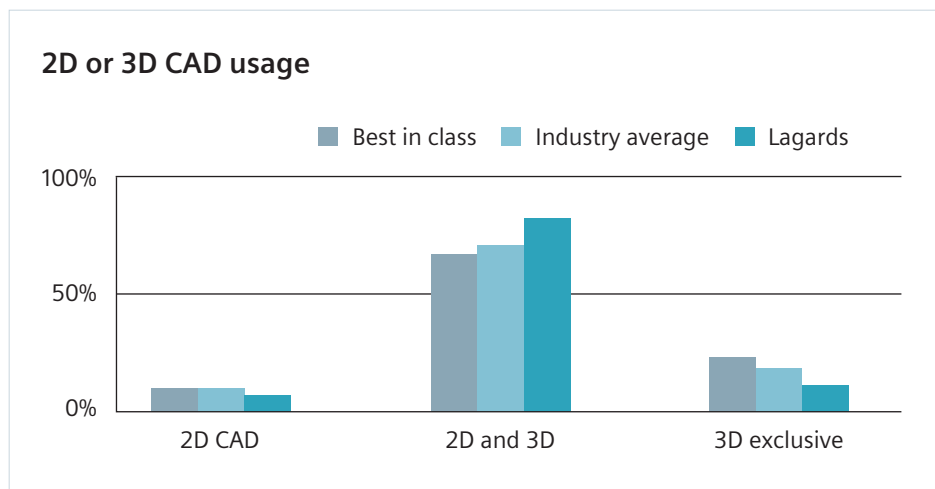

Figure 1: Most organizations use both 2D and 3D CAD systems during the transition to 3D. This strategy helps them learn new concepts and leverage 2D into 3D while keeping production going. Best in class 3D users are taking their process to the next level with automated manufacturing and analysis. Source: Aberdeen Group, May 2008

# Use 2D where it makes sense

While 3D is the technology of choice for product design, 2D still has its place in the designer's toolbox. Some design tasks are better suited for 2D, such as machinery or plant layout development. But any work done in 2D should be readily available for 3D design. Finding a 3D system that supports these requirements can be a challenge.

Solid Edge with synchronous technology is designed to do just that and in a single system. Existing 2D drawings can be opened, edited, optimized and be later used in 3D, while new 2D layout sketches can be easily generated.

## Creating 2D layouts

Layouts are often an initial step in outlining material routing through factories or machines. Using 2D at this stage gets concepts down quickly and facilitates fast change, playing a critical role later during 3D part design. Designers can use layouts to speed 3D component modeling while ensuring fit and position. As a result, your ability to use 2D directly in 3D becomes critical.

Solid Edge with synchronous technology offers both 2D and 3D design systems that work together. Drawings created in 2D (or imported from other systems through various 2D formats), can be edited or used directly in the 3D design process. A wizard improves imports by mapping drawing entities such as fonts and line-styles, and handling black/white background color conversion. Concepts such as model space/paper space and cross references to other drawings are also supported. After the import, drawings can be automatically constrained adding intelligence and predictability when changes are made. Layouts consisting of geometry, dimensions and layers can be brought into 3D at any time for component positioning and design.

## Optimizing 2D drawings

Almost all designs require multiple calculations ranging from computations that determine structural rigidity to optimize part locations. Many designers use free-body diagrams as a common practice for solving complex calculations. Drawing and solving 2D sketches greatly simplifies this process and if the results can drive 3D, design becomes more efficient.

Solving free-body diagrams can be done in Solid Edge through the use of the Goal Seek feature, a built-in utility that solves one unknown parameter by adjusting another. The user simply constrains a sketch that simulates a systems behavior and indicates both a goal value and what will float. Goal Seek then solves the variable parameter until the target value matches the goal. Typically, the Goal Seek feature is used to determine correct beam sizes given a specific load,

as well as to optimize pulley configurations given a fixed belt length, as shown in figure 2. An additional benefit from Goal Seek is that optimized 2D sketches drive component positions.

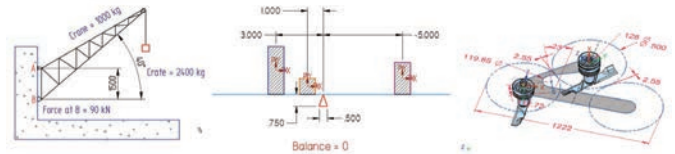

Figure 2: Goal Seek optimizes 2D sketches that simulate a mechanical mechanism, letting designers do "what-if" scenarios before committing to 3D design. As sketches can drive the fit and position of 3D components, Goal Seek provides a simplified way to optimize complex assembly designs.

Use 2D where it makes sense but it's imperative that drawings can be used in 3D. To help designers get started in optimizing 2D layouts, Solid Edge 2D Drafting can be downloaded from Siemens website free of charge. With Solid Edge, users can create and open 2D drawings, optimize with Goal Seek and feed the results into 3D.

### At a glance: Sparkonix India Pvt. Ltd.

Sparkonix India's primary business is manufacturing electrical discharge machining (EDM) machines, CNC wire cutting machines and metal arc disintegrators. For this company, design in 2D was no longer an option, but is still critical for shop floor documentation.

Using Solid Edge, Sparkonix is able to visualize movement and detect collisions, create drawings automatically and provide better customer sign-offs using CAD renderings resulting in a 30 percent reduction in design time and 40 percent cost savings in design, castings and prototyping.

"It was great to look at the 3D model of the machine. Preparing the layout for the machine was simple, giving us a clean view of the assembly – something we never had previously. Preparing the BOM is also easy, we just select the view and 'boom,' the BOM is ready."

Anand Atole  
Senior Executive Designer  
Sparkonix India Pvt. Ltd.

# Leveraging 2D into 3D design

It shouldn't matter if a design is in 2D or 3D, if it exists – use it. The challenge is how to best re-use 2D in 3D. Moving drawings of parts into 3D can be straightforward, but assembly layouts tend to be more complicated because they can contain envelopes, parts lists and component details. Finding a system that can leverage 2D for 3D part creation, parts list development and assembly definition is a challenge.

Solid Edge with synchronous technology's tools facilitate the re-use of 2D drawings for part creation, parts lists development and assembly design.

## Creating 3D parts from 2D drawings

Many companies wish to convert 2D part drawings to 3D models. This process is assisted by Create 3D, a tool that copies and aligns 2D drawing views into 3D parts. Once the sketches are created, a simple drag transforms the 2D geometry into 3D and any 2D dimensions become editable 3D driving dimensions. Figure 3 shows the main parts of this process, including a drawing, the created 3D tool and the completed 3D part. Unlike traditional 3D CAD systems, the created 3D geometry that Solid Edge produces is not dependent on each other. As a result, users do not have to plan the modeling steps. While this topic will be discussed in detail later in the white paper, it is important to realize that eliminating these design steps both eases and speeds most companies' adoption of 3D.

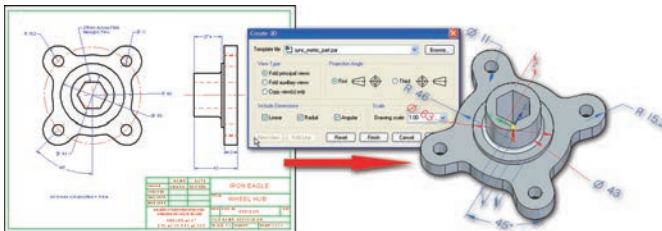

Figure 3: Create 3D transforms 2D drawings into editable 3D parts, without requiring the user to learn and manage a history-based design approach.

## Define the parts list before 3D

Defining the parts list of a new product early in the process enables companies to estimate their design costs before expensive design time is spent. Outlining key components in 2D is a well known practice, but doing the same in traditional 3D generally requires physical parts. However, a unique Solid Edge approach enables designers to define a complete assembly structure with "virtual components". Figure 4 shows how users can define the assembly structure using these components. Manufacturing, purchasing and management teams can leverage this feature to quickly size up the scope of a new product. Part sketches can also be linked to each virtual component and later pushed into each 3D part to assist in the modeling process.

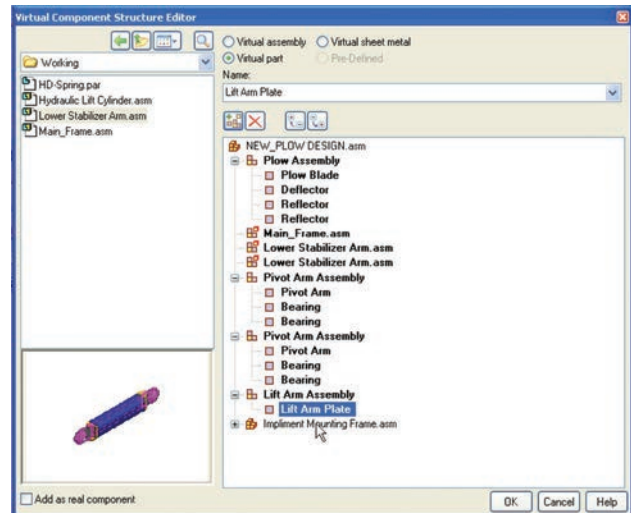

Figure 4: A complete assembly can be created without physical components. Defining the assembly structure with virtual components lets changes be made faster in the conceptual development stage.

### Using 2D layouts to drive 3D assemblies

Companies know the importance layouts play in assembly design. Regardless of industry, it's common practice to define in 2D, the fit and position of 3D parts, as well as complete machines. A hybrid approach in Solid Edge lets users mix and match 2D layouts with 3D components. Layouts can be created or imported from other systems, optimized with Goal Seek, used as a guide part positioning and then used to create the actual 3D components. Figure 5 shows a factory floor layout that defines the locations of the machinery. Should the location of a machine need to be moved, the 2D sketch is simply edited.

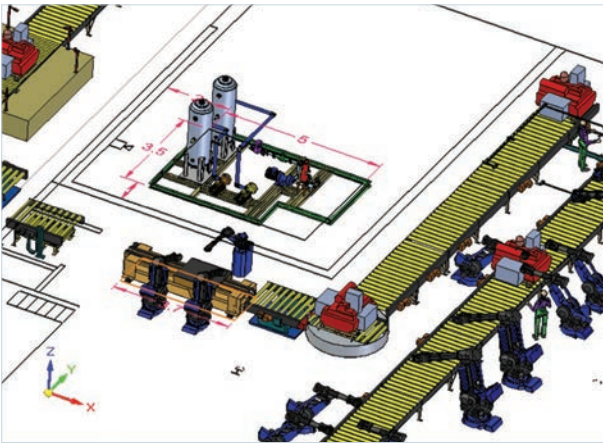

Figure 5: Solid Edge uses a hybrid 2D/3D design process that links 2D layouts and 3D components. Should changes be made to the flow detailed by the layout, the machine locations can update to reflect the new design.

By leveraging 2D drawings in the 3D design process, companies are better positioned to re-use existing data. Solid Edge offers methods to assist 3D modeling using both parts and assembly drawings.

### At a glance: Triumph office furniture

Triumph is one of the UK's leading designers and manufacturers of steel office furniture and storage solutions. To keep up with customer demands, 3D design tools were required.

Triumph learned that Solid Edge enabled users to continue working on existing 2D drawings and later leverage them into 3D models. This hybrid 2D/3D design approach resulted in a 50 percent reduction in time required to develop a new line of steel office storage products.

"The software was picked up and implemented within a week of receiving a copy; we did not believe any of the other systems could be up and running so quickly, making the decision easy for us."

Nick Wilding  
Senior Designer  
Triumph

# 3D with the simplicity of 2D

Engineers using 2D are familiar with how to design and edit and while 2D systems may not be as powerful as 3D, at least the design principals are known. History-based systems utilize constraints to control what happens to the model during edits and requires careful planning or “programming” during creation. Users are concerned with the downtime spent learning a completely different way of designing, editing and handling imported data.

Solid Edge with synchronous technology uses a new innovative approach that combines the speed and flexibility of explicit modeling systems (which includes 2D), with the precise control of parametric 3D CAD. Figure 6 shows how the best of both technologies has been brought into a single system while leaving the negative aspects out.

## 3D model creation

Because synchronous technology is history-free, Solid Edge 3D features can be created without planning how they interact – much like 2D, where lines, arcs and circles are created in any order. Without specific modeling commands, sketches can be immediately dragged into 3D shapes and geometric conditions such as concentric faces, tangent horizontal and vertical faces are maintained without having to define that behavior. Relationships and 3D driving dimensions can be added at any point during design, and to virtually any part of the model. This approach lets users create parts quicker because less time is spent manipulating commands and determining the order in which to use them.

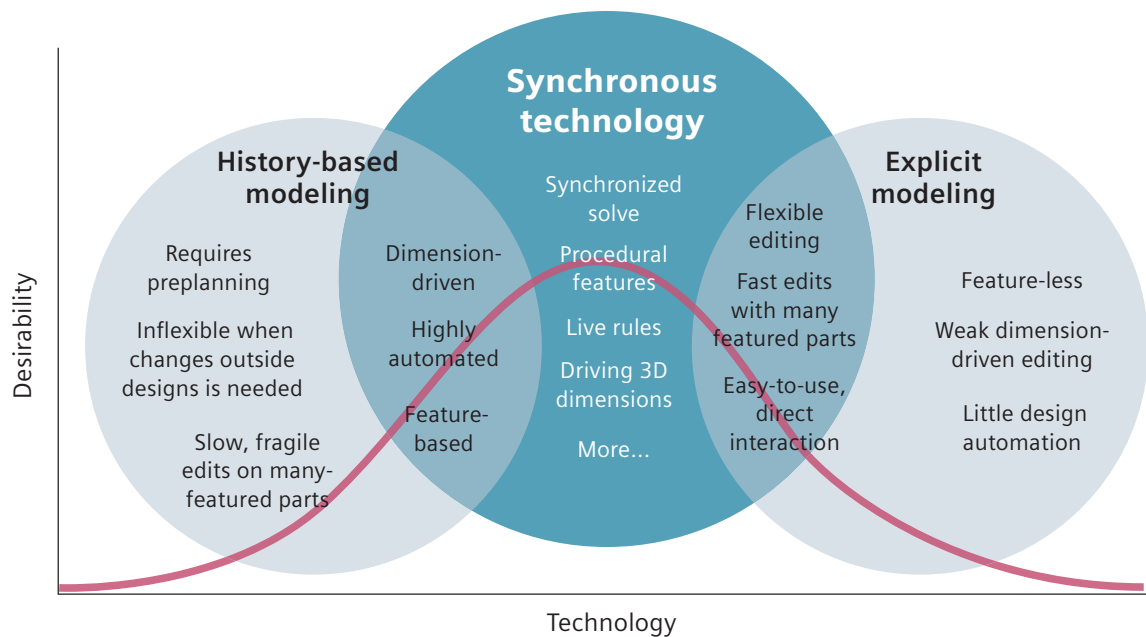

Figure 6: Solid Edge with synchronous technology combines the speed and flexibility of explicit modeling systems (including 2D) with the precise control of feature-based parametric systems – all while omitting the undesirable side effects of each.



### 3D editing

Models created using synchronous technology support automated design changes, so a modification to one feature can affect another without regenerating unrelated geometry as with traditional systems. Because features are independent of each other, more flexible changes can be made with a fence stretch or by editing a 2D cross section placed at will. Figure 7 shows a part with edit results superimposed where the mounting hole, highlighted in blue, is moved and the overall part changed to maintain concentric and tangent model conditions. A unique concept called Live Rules keeps the model together as concentric, tangent and vertical or horizontal faces are automatically maintained.

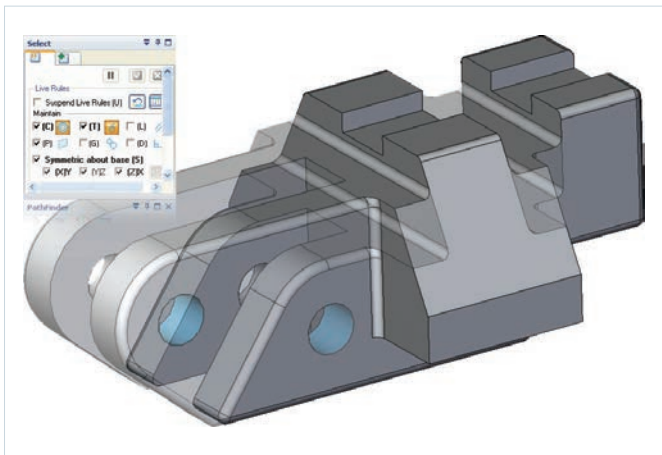

Figure 7: A unique concept in synchronous technology, called Live Rules finds and maintains geometric conditions such as tangent, coplanar and concentric conditions, without explicitly defined constraints. This gives tremendous edit flexibility in making unplanned changes – a similar approach in how 2D is edited.

### Handling imported 3D models

Most drawings can be used between different 2D systems because there is no design history to convert. That's not the case with history-based 3D because the model steps aren't portable, hence edit capabilities of imported or supplier data is sacrificed. Edit operations in Solid Edge with synchronous technology are designed to work equally well on imported data. Edits can be made with added 3D driving dimensions or by dragging faces or groups of faces recognized by function. During the change, strong geometric model conditions are kept with Live Rules. The part in figure 7 could be either a native design or imported from a supplier, but a change would yield the same results.

#### At a glance: Razor USA LLC.

Razor USA LLC rapidly grew from a company with a single product (the popular Razor kick scooter) to more than 30 human and electric-powered toys.

Staying innovative is tough and being able to narrow down hundreds of ideas down to a few is critical. Finding a system that would allow quicker design iterations but easy for its 2D users to adopt were the key requirements. Solid Edge with synchronous technology let Razor to just that.

"I just turned our last AutoCAD user loose on Solid Edge with synchronous technology. Since there are no complex history rules or modelling strategies to learn, he picked up Solid Edge very easily. In just a few weeks, he's already cranking out designs left and right. He's just incredibly excited about finally joining the 3D club!"

Bob Hadley  
Product Development Manager  
Razor USA LLC

# Getting 2D from 3D

In most companies, 2D drawings are the primary deliverable. They are used to communicate critical design details such as dimensions, tolerances and parts lists. In order to reduce misinterpretation by different departments, drawings must be accurate and understandable. While most 3D CAD systems can create 2D drawings from the 3D model, the main challenge is being able to create and manipulate 3D designs.

Because of the importance on accurate drawings, the capabilities offered by synchronous technology become more necessary to 2D users. Because of faster 3D model development, designers can begin to create drawings sooner in the design process. Similarly, drawing changes can happen faster because users don't need to be system experts.

## You can get there from here

Creating 2D drawings automatically requires a 3D model but the difficulty 2D users face is model development. Creating and extruding sketches is a simple process to learn, but in most systems a separate command is required for each operation. Interacting with multiple commands and establishing how they work together can result in slow model development – and a delay in drawing creation.

Synchronous technology in Solid Edge incorporates a more direct way to create 3D models where sketches and model faces are pushed and pulled into shape. Editable 3D dimensions can be added to the completed model and are more useful when retrieved in drawings. Feature dimensions used in history-based systems often don't capture the end result and aren't helpful on drawings. Synchronous technology enables companies to create drawings earlier in the design process.

## Making drawing refinements

When it comes to drawings derived from 3D models, drawing changes originate in 3D. As with most 3D CAD systems, once a change is made, 2D drawing views update accordingly and any applied dimensions reflect new sizes. The process is fairly automatic, but 2D users familiar with moving lines and stretch editing, are wary about how to manipulate history-based models to achieve a specific result.

Edits in Solid Edge with synchronous technology aren't bound to the limitations of history, so flexible changes can be made more intuitively. For example, figure 8 shows a 3D component during an edit, where the user simply drew a fence and stretched geometry into shape – a similar approach used in 2D. As changes only affect related geometry, there is less chance that undesirable effects will cause inaccurate drawings.

When creating 2D drawings, it's important to consider the time it takes to create and refine 3D models. Having a system

that offers the automation and accuracy of 3D but leverages some of the simplistic approaches used in 2D can expedite the overall drawing process.

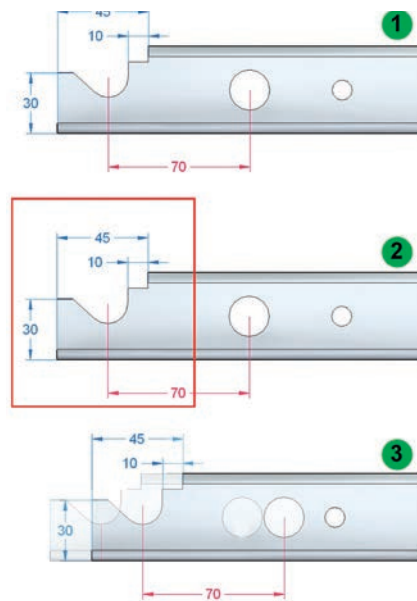

Figure 8: Edits in Solid Edge with synchronous technology are fast and flexible using fence stretching. Step 1: a part or assembly is opened, step 2: a 2D fence is drawn around a set of 3D parts and geometry and step 3: the geometry is dragged to key points or with dimension precision.

## At a glance: L.S. Starrett Company

The L.S. Starrett Company has a reputation for manufacturing high quality precision tools, gauges, measuring instruments and saw blades for industrial, professional and consumer markets worldwide.

Since Starrett heavily relies on 2D drawings, it needed to keep the ability to use them during and after its move to 3D. With Solid Edge, the company was able to transition to 3D without disrupting its 2D design process. The ability to maintain 2D and leverage into 3D, resulted in more product documentation in less time.

"We bring our old 2D files into Solid Edge and use its tools to turn curves and lines on the drawings into 3D models with a few clicks."

Jim Woessner  
Design/drafting supervisor  
L. S. Starrett

# Conclusion

Moving from 2D to 3D is not a difficult proposition; every-day, companies are making the transition. While the benefits of 3D are well known, the most effective pathway to 3D has not been as well documented. This white paper outlines some of the key areas where companies can best leverage existing 2D drawings and describes how to utilize them in a 3D design process. While there are 3D design tools available, the underlying history-based technology can yield only marginal results. Leveraging 2D drawings and techniques offered by Solid Edge with synchronous technology will help companies accelerate the move to 3D and maximize its full potential for thriving in the 2D to 3D to 2D world.

## Further reading

Goal Seek: An automated approach to solving 2D free body diagrams

Hybrid 2D/3D Design: How to best leverage 2D into the 3D assembly design process

Diagramming in Solid Edge: Details a dedicated approach and library of parts

Plant equipment design and layout: How to design 3D plants from 2D layouts

Product Demonstrations: See Solid Edge with synchronous technology in action

L. S. Starrett Co: A use case in leveraging 2D into 3D

Triumph Office Furniture: A use case in for Hybrid 2D/3D design

Razor Scooter: A use case in adopting 3D faster

## Siemens PLM Software

### Headquarters

Granite Park One  
5800 Granite Parkway  
Suite 600  
Plano, TX 75024  
USA  
+1 972 987 3000

### Americas

Granite Park One  
5800 Granite Parkway  
Suite 600  
Plano, TX 75024  
USA  
+1 314 264 8287

### Europe

Stephenson House  
Sir William Siemens Square  
Frimley, Camberley  
Surrey, GU16 8QD  
+44 (0) 1276 413200

### Asia-Pacific

Suites 4301-4302, 43/F  
AIA Kowloon Tower, Landmark East  
100 How Ming Street  
Kwun Tong, Kowloon  
Hong Kong  
+852 2230 3308

## About Siemens PLM Software

Siemens PLM Software, a business unit of the Siemens Industry Automation Division, is a world-leading provider of product lifecycle management (PLM) software, systems and services with nine million licensed seats and 77,000 customers worldwide. Headquartered in Plano, Texas, Siemens PLM Software helps thousands of companies make great products by optimizing their lifecycle processes, from planning and development through manufacturing and support. Our HD-PLM vision is to give everyone involved in making a product the information they need, when they need it, to make the smartest decisions. For more information on Siemens PLM Software products and services, visit [www.siemens.com/plm](http://www.siemens.com/plm).

## [www.siemens.com/plm](http://www.siemens.com/plm)

© 2014 Siemens Product Lifecycle Management Software Inc. Siemens and the Siemens logo are registered trademarks of Siemens AG. D-Cubed, Femap, Fibersim, Geolus, GO PLM, I-deas, JT, NX, Parasolid, Quality Planning Environment, Solid Edge, Syncrofit, Teamcenter and Tecnomatix are trademarks or registered trademarks of Siemens Product Lifecycle Management Software Inc. or its subsidiaries in the United States and in other countries. Nastran is a registered trademark of the National Aeronautics and Space Administration. All other logos, trademarks, registered trademarks or service marks belong to their respective holders.

19071-Y1 8/14 C