

# NX I-deas Master Drafting

## Benefits

- Changes to the three-dimensional geometry drive updates to the two-dimensional geometry and dimensions
- The two-dimensional geometry creation tools and Dynamic Navigator user interaction model provide maximum user productivity for creating standalone drawings
- Creation of drawings from NX I-deas Master Notation model views prevents duplicate effort when some down-stream users require the two-dimensional drawing
- Comprehensive set of translators allows easy exchange of drawings with suppliers and OEMs who are using different drafting tools

## Features

- Automated and associative drawing view creation using three-dimensional geometry from Master Modeler and Master Assembly
- Bottom-up two-dimensional geometry creation tools for standalone drawings
- Dynamic Navigator sketching tools

## Summary

NX™ I-deas™ Master Drafting – an add-on module within NX I-deas software – is a powerful two-dimensional documentation environment for creating detailed production mechanical drawings. Master Drafting can be used to create associative two-dimensional documentation of three-dimensional product geometry created in NX I-deas Master Modeler and NX I-deas Master Assembly; or it can be used to create standalone drawings using a complete set of 'bottom-up' two-dimensional geometry creation tools. In either scenario, Master Drafting provides a complete and robust set of documentation tools that follow the latest industry standards.

## For documenting NX I-deas designs

Master Drafting is used by engineers, designers, drafters and detailers to create detailed production mechanical drawings. It can be used as a tool for documenting solid models created in Master Modeler to create associative drawings, or as a standalone, high-performance 2D drafting system to create standalone drawings.

Master Drafting uses the Dynamic Navigator style of user interaction. Orthographic, section, detail and auxiliary views are easily created from the master model geometry along with dimensions and geometric dimensioning and tolerancing (GD&T) symbology. Drawings are associative to the master model, and the integrated data

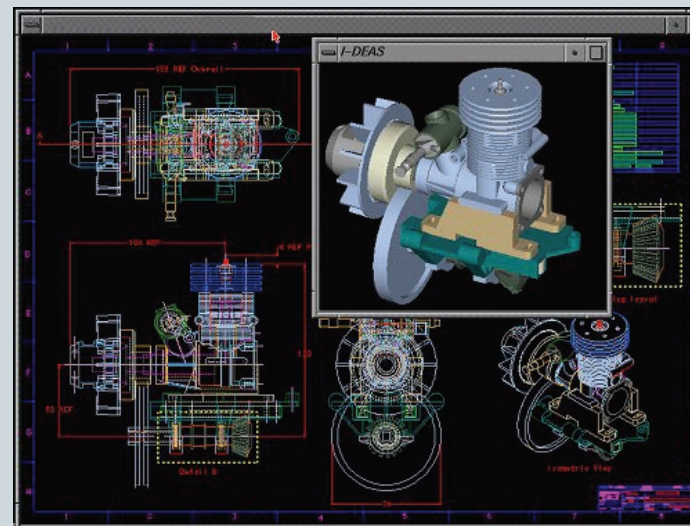

*Master Drafting is used by engineers, designers, drafters and detailers to create detailed production mechanical drawings.*

NX

[www.siemens.com/nx](http://www.siemens.com/nx)

SIEMENS

# NX I-deas Master Drafting

## Features *continued*

- Associativity to Master Notation model views for consistent three-dimensional and two-dimensional dimensions and annotation
- Comprehensive data input/output capabilities including IGES, DXF, CADAM and AutoCAD
- Comprehensive plotting tools

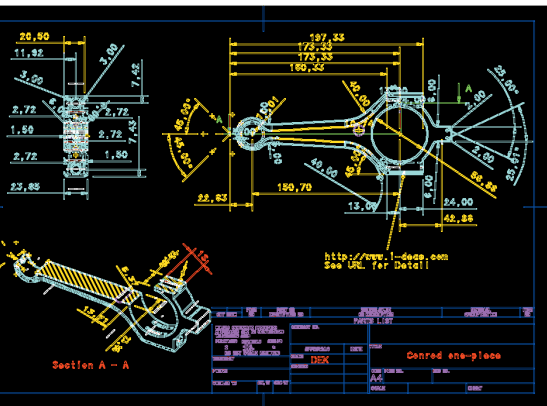

Master Drafting includes both documentation tools which are associative to 3D geometry, as well as bottom-up 2D drawing tools.

management system tracks drawings and maintains relationships to the models from which they were created.

As a standalone system, Master Drafting not only provides complete detailing capability, but functions effectively for concept design as well. Variational sketching provides broad capability for geometry creation and captures design intent to ease design change. A dynamic icon palette and the Dynamic Navigator make Master Drafting easy to learn. It is a good starting point for organizations transitioning to solids-based design from traditional systems. Users can rapidly become proficient with Master Drafting, and achieve measurable productivity gains over previously used tools. As appropriate, these users can grow directly into solid modeling without losing data.

## Solids-based associative drawings

For organizations that use a solids-based approach to design, Master Drafting provides many advantages, including the integration with Master Modeler, Master Assembly and Master Notation. Master Drafting provides capabilities in several areas:

- A model window assists users with creating new views, and provides a means to see the master model and understand its topology and documentation requirements, without the need to access other modules
- Concurrent associativity allows a drafter to start a drawing from the master model while the designer continues working on the same design. Subsequent design changes to the master model can be used to update the drawing
- An independent drawing is created that can be accessed, modified and completed without the need to retrieve the solid model or assembly
- 3D model views created in Master Notation can easily be placed on any drawing, providing one of the fastest ways to create a drawing that documents the solid design. Subsequent changes to the 3D model views can be used to automatically update the drawing
- Knowledge of the solid is embedded within the drawings that document solid models. This allows the drawing to extract precise dimensional information directly from the solid geometry, and to track the geometry through any changes it may undergo

## High-performance detailing

Master Drafting provides you with many tools to fully document your solid designs. All geometry details don't need to be modeled in the Master Modeler; additional geometry can easily be added to adequately detail the design for such characteristics as tapped threads, screw head types, etc. Geometry can be created in Master Drafting, incorporated from user-defined symbol catalogs or retrieved from the optional Master Drafting symbols catalog.

Master Drafting offers a wide variety of dimensioning techniques which use the

Dynamic Navigator style of user interaction. As you traverse the drawing, geometry entities are highlighted. Appropriate icons are displayed next to the cursor that represent the dimensions that can be added to entities simply by picking with the cursor. This innovative approach reduces menu selection and picking, and significantly improves the productivity of the dimensioning function. Dimensioning within Master Drafting supports the international standards ANSI, ISO, DIN, BSI and JIS. Notes and text needed to complete your drawing are easily added with an integrated paragraph text editor. A local language editor can be integrated so that notes in international character sets can be created directly in the Master Drafting session.

- A full complement of geometry creation capabilities for adding design detail not created in the master model, including cutting plane lines and break marks; associative crosshatching with the ability to recognize internal holes and islands; and standard and user-defined symbols with dynamic placement and the ability to nest, scale, rotate and mirror
- Comprehensive associative dimensioning capabilities, including dynamic dimensioning; dimensions automatically inherited from Master Modeler or Master Assembly; dynamic repositioning, editing and automatic respacing; intelligent witness-line breaks; and single or dual tolerances
- Geometric dimensioning and tolerancing (GD&T) may be inherited from the master model or master assembly, or easily created in Master Drafting
- Complete view creation capabilities allow you to choose view direction, or choose from common layout types such as "front," "top," etc., or set up orthographic views in first or third angle projection, isometric, auxiliary or true views. Multiple views of one or more parts or assemblies can be placed on one drawing or multiple drawings, or on multiple sheets

## Drawing management

Master Drafting includes the Team Data Manager integrated drawing management capabilities. You can start by searching for a drawing by its file name, any title block

information that the user sets (title, part number, part name, drafter's name, etc.) or project name. You can manage all of your drawings, whether associated to a solid model, or just a standalone 2D drawing. You can determine which master model every drawing came from, or see all of the drawings that came from a particular master model. Team Data Manager also allows you to configure a project's drawing access privileges, track revisions and versions and track drawing states (in-design, check, released, etc.) as a drawing moves through your design process.

### Standalone drafting

Master Drafting functionality is available for standalone implementation without the requirement of any other NX I-deas module. This allows you to tailor your software acquisition to meet your specific needs. The integrated drawing management, combined with extensive geometry creation capabilities, is available with the standalone system to make Master Drafting a substantial design tool in its own right:

- The variational sketching with Dynamic Navigator allows rapid geometry creation; geometric and dimensional constraints; real-time, dimension-driven drawing changes; equational relationships between constraints; complete 2D geometry creation and editing; and dynamic dragging
- Create entities by projecting multiple geometric entities from a view into all other views and automatically providing the silhouette lines and connecting the edges. This extremely powerful technique virtually removes the need for most construction geometry and can save hours of drawing time

- Extensive measurements and properties calculations include distance and angle; perimeter; area; moments and products of inertia about centroid, XY axis and origin; radius of gyration; polar moment of inertia; and generate point entity at centroid

### Customization

Master Drafting provides capabilities for modifying the system to company requirements. It lets you customize the icons to better fit your needs, set site-definable defaults, set up company-specific standard drawing formats, create macros to automate tasks, or build application programs.

### Translators

Master Drafting includes functionality to allow you to exchange data with other CAD and CAM systems via 2D IGES and 2D DXF translators. These translators provide accurate bi-directional exchange of data between Master Drafting and these two industry standards. Optional modules also provide direct translation to and from CADAM, and to and from AutoCAD dwg. These capabilities allow Master Drafting to co-exist with other CAD systems or to be used by organizations transitioning from other systems, but wanting to retain the investment already made in CAD data:

- Growth to solids-based, team-oriented mechanical automation, using the translators as an initial step in the evolution from an existing CAD toolset to the engineering solution provided by NX I-deas. Once translated, the Master Drafting user has the opportunity to migrate to Master Modeler where existing 2D data can be directly used to create solid models

- Exchanging data with suppliers and other vendors using other CAD products may provide new opportunities for Master Drafting customers to work with prime contractors or leverage subcontractors who already perform their drafting and design tasks using another CAD product

### Drafting Symbols Catalog

The Drafting Symbols Catalog may be purchased as an optional module, with Master Drafting being a prerequisite. The catalog is a comprehensive mechanical and electrical symbols catalog used as an extension to Master Drafting, containing more than 20,000 symbols. The catalog is based on ANSI, JIS and ISO standards which are currently in use throughout the industry. It consists of mechanical fasteners, electrical and electronic symbols, HVAC, fluid power, heat power, piping symbols, welding symbols and standard drawing borders for complete production-quality drawings.

The catalog conforms to international standards, but you may still modify any of the symbols to conform to your specific company requirements. You may also add your own custom symbols to the library. To aid in the creation of your own specific standards, symbols may be nested, scaled, rotated, mirrored or globally changed in Master Drafting.

Contact  
Siemens PLM Software  
Americas 800 498 5351  
Europe 44 (0) 1276 702000  
Asia-Pacific 852 2230 3333

[www.siemens.com/nx](http://www.siemens.com/nx)

© 2011 Siemens Product Lifecycle Management Software Inc. All rights reserved. Siemens and the Siemens logo are registered trademarks of Siemens AG. D-Cubed, Femap, Geolus, GO PLM, I-deas, Insight, JT, NX, Parasolid, Solid Edge, Teamcenter, Tecnomatix and Velocity Series are trademarks or registered trademarks of Siemens Product Lifecycle Management Software Inc. or its subsidiaries in the United States and in other countries. All other logos, trademarks, registered trademarks or service marks used herein are the property of their respective holders.  
X3 2805 2/11 B