

Solid Edge OEM supply chain collaboration

SIEMENS

White Paper

Fostering innovation and supply chain synchronization through an open data model that enables collaboration and interoperability between design systems.

Contents

- Introduction.....3
- Design collaboration challenge4
- Visualization and collaboration using JT data5
- PMI – Improved design reviews8
- XpresReview10
- XpresReview interface and features12
- Interoperability – Solid Edge, NX and I-deas14
- Edit outsourced CAD data faster than the vendor who supplied it.....15
- Using NX data in Solid Edge.....16
- Conclusion.....17

Introduction

Globally distributed partner networks are no longer the sole domain of large OEMs. It is now common for small and mid-size companies to participate in or even drive multiple, highly competitive supply chains, each placing rigorous demands on product development speed, quality and costs.

Collaboration is critical to successful product design, and with Solid Edge® software, OEMs and suppliers can improve and manage collaboration across design teams, regardless of location. By reducing design revisions and communication delays, our customers enjoy better time-to-market and increased profitability.

Solid Edge built-in data sharing, design communication and interoperability capabilities deliver cost effective, collaborative design tools throughout the entire OEM and supplier value chain. By delivering complementary technologies, communication between customers and suppliers – using easy-to-visualize, accurate and up-to-date information – reduces misinterpretation across all points of the value chain to successfully convert raw ideas into new business and respond quickly to emerging risks and opportunities.



Road to innovation

If you want your company to be a market leader, you need to innovate relentlessly. Today's most forward-thinking companies are continuously optimizing and improving products and processes – and organizing their value chain so that innovation can flourish.

By allowing distributed value chains to work together as a single enterprise, these “innovation networks” drive today's crucial business imperatives. To achieve this level of collaboration companies must find new sources of innovation that extend well beyond in-house invention. Therefore more and more best-in-class companies are choosing new roads to innovation. Solid Edge is the most cost effective, complete and open solution for 2D and 3D design and collaboration, helping you meet these key business requirements:

- Accelerate top-line growth
- Contain costs
- Reduce time-to-market
- Optimize resources
- Leverage globalization
- Innovate more

Design collaboration challenge

Many product development processes rely on a frequent exchange of information among different stakeholders. Organizations pass information back and forth between internal engineering and manufacturing groups, as well as with supply chain partners. Unfortunately, data communication and information exchange are often hampered by differences in the product development systems used by the partners.

Bringing together different organizations across a supply chain is good for business, but from a design and collaboration standpoint it is not without its challenges. Many companies will more than likely use disparate CAD systems or have a generic means to share and collaborate on design projects. Without efficient collaboration tools, companies can lose business, find they are unable to compete, or design or manufacture around out-of-date information. To eliminate these issues, all parties throughout the supply chain need to be able to collaborate and share data directly from their design systems – utilizing higher levels of collaboration and data exchange to reduce project cycles, speed up communication and eliminate errors. Siemens PLM Software understands these challenges and provides several ways for companies to share data and collaborate, depending on the level of information required. From JT™ lightweight data transfer to tight interoperability between Solid Edge and NX™ software, Siemens PLM Software's open business and data models enable:

- Communication between customers and suppliers using easy-to-visualize, accurate and up-to-date information that reduces misinterpretation as designs pass through the supply chain
- Collaboration tools for shortened and more decisive design reviews, helping cross-departmental and cross-functional teams make faster decisions to meet shrinking delivery cycles and customer expectations
- Faster evaluation of design options early in the design phase, so changes can be incorporated while costs are low

Making collaboration easier

Siemens provides collaboration enablers (tools) that help companies efficiently share data and collaborate within their supply chain at a level appropriate for each scenario. JT files provide a CAD-neutral, lightweight method of exchanging data between disparate CAD systems, and allow companies to share an appropriate level of intelligence that protects intellectual property. Product manufacturing information (PMI) is used to relay manufacturing details with 3D design data. PMI can be included with native Solid Edge/NX data and included with JT files, reducing the need for drawings in design reviews. Solid Edge XpresReview delivers free design collaboration including view and markup. For companies working close together with a need to exchange native CAD data for collaborative design and manufacturing, Solid Edge and NX associatively exchange native data using PLM XML interoperability capabilities built into each product.



Visualization and collaboration using JT data

Global companies require efficient tools for exchanging design data, even when their partners are using disparate design tools. JT provides global partner networks with a product design collaboration workflow to improve designs and deliver products to market faster. With more than 4 million users worldwide, JT is proven technology and widely accepted as the standard for collaboration, allowing anyone in the value chain to share intelligent 3D data regardless of the CAD system used to create the file. JT files contain all the important design data needed to collaborate in today's engineering world. Different combinations of geometric information, assembly structure and attributes allow OEMs and suppliers to share a level of "intelligence" and security that is appropriate to each shared project. Communicating with customers and suppliers using easy-to-visualize, accurate and up-to-date information reduces misinterpretation as designs pass through the supply chain.

Solid Edge has the capability to open JT (part or assembly) files directly including the assembly structure, either through File Open or Insert Part Copy. JT files can contain either facets or Parasolid® B-Rep software or both. When Solid Edge reads in a JT file, it uses the highest intelligence rep it can find: Parasolid B-Rep (solid) is first and then if no B-Rep is found, it reads the JT facets to be used as a reference part. The import export wizard provides full manual overrides should users need that extra bit of control. Additional attribute, property and PMI information can be added, communicated and exchanged between (to/from) JT and Solid Edge files.

Physical properties and interference checking are also supported, including a mix of B-Rep and faceted parts, allowing Solid Edge to be used as a "CAD neutral" assembly tool without having to recreate parts that already exist in other 3D systems.

JT technology in use

JT is a mature lightweight data format that already enjoys widespread use in the automobile and aerospace industries and is equally suitable for all manufacturing industry applications. The success of JT and applications that exploit it is such that JT has become the preferred common data format for many large end-users. The JT data representation is:

- A rich data model with robust entity support
- A high-performance, compact persistence archive format for graphics data
- The best-in-class for supporting large assembly/model interactive capabilities
- CAD-neutral supporting all major MCAD applications
- Supported in many free viewers including XpresReview and the Solid Edge Viewer

Software product development organizations have developed translators from the popular MCAD systems into JT. It is nearly always the only format common to the major applications that might be used in an enterprise.

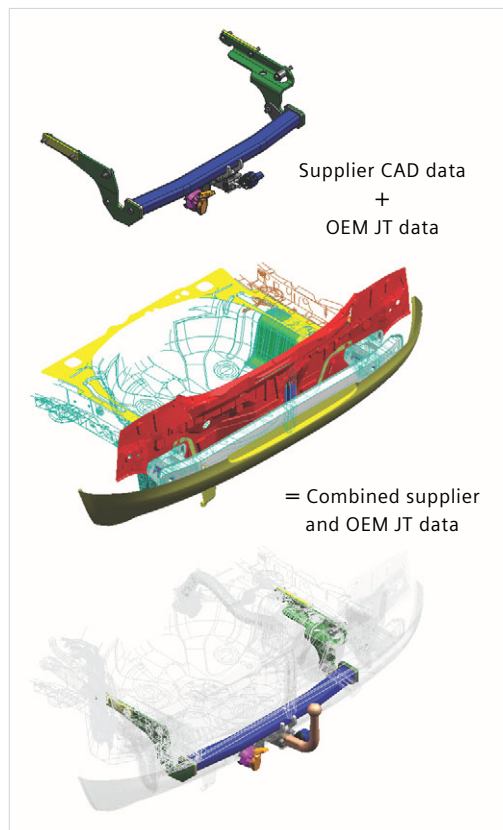

Robust entity support

JT files provide a versatile container for many different entity types, allowing companies to include all the important design data needed to collaborate in today's engineering world, which allows OEMs and suppliers to share a level of "intelligence" and security combinations that are appropriate to their shared projects. JT files can contain precise or faceted geometry, surfaces and construction curves as well as part property information. The next paragraphs describe how they can be used.

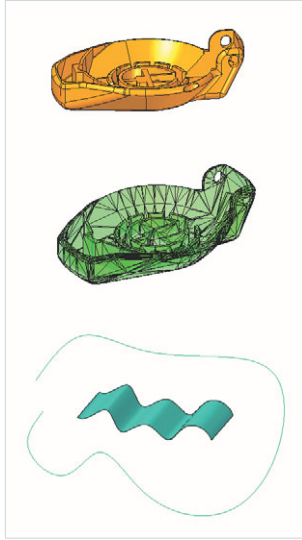

- Lightweight faceted body (tessellated representations)
- Support of precise geometry
 - Both Parasolid (X_T) and JT B-Rep
 - Solid bodies
 - Construction surfaces
 - Construction 3D curves
- PMI
- Attributes/file properties

"With JT, we can do things with less work. We can use standard assemblies from suppliers. JT can be used with links in Solid Edge. JT saves us money... we can measure modeling in hours now."

Jürgen Niesner
CAD System Manager
Maschinenfabrik Reinhausen

JT document structures

JT has a variety of supported document structures for parts and assemblies depending on how the data is to be used and the level of detail required. Assembly files can be exported into a monolithic, or single JT document, that stores only the space envelope, removing individual components and assembly structure to protect intellectual property and reduce file size. Assemblies can also be saved as a single JT assembly document with all individual parts within separate JT files. When imported into Solid Edge you will see a flat assembly structure. A third option creates a single JT file that contains all of the parts and subassemblies, which preserves the assembly structure; all parts and subassemblies are as they were in the original CAD system.

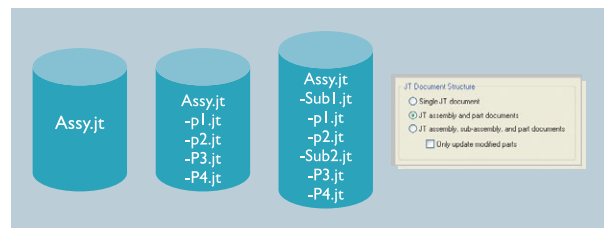

Using precise geometry

JT files can contain two types of precise geometry. Parasolid (X_T) B-Rep geometry is the default standard that Solid Edge uses. JT files can also contain JT B-Rep data which may be exported from other systems. When importing JT data, Solid Edge first looks for the Parasolid representation but if none exists it can read JT B-Rep data.

Importing JT files that contain precise geometry allows full reference of the data contained within the JT file. Using precise data you are able to create assembly

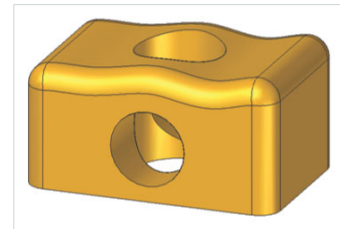

constraints (mates, alignments etc.) to the imported JT data to create associativity with adjacent components or use-in-motion studies. Physical properties are maintained and can be used in mass or volume calculations. Full interference checking capabilities are supported. Parts can be used to create high quality drawing views; you can integrate exact dimensions and create PMI data with precise dimensions to the imported JT data.

Using faceted bodies

Lightweight faceted bodies contain only tessellated representations of parts which very closely approximate the components' size, shape and volume.

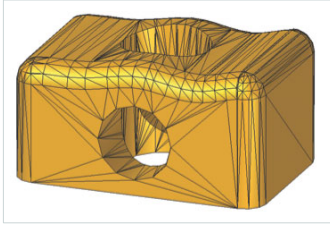

Facets are for viewing and are also used as reference while working on assemblies. You can calculate physical properties for faceted bodies, locate them when checking for interference in assemblies and create draft quality drawing views. Faceted bodies in JT files contain the least amount of data and deliver the smallest file size.

Importing JT documents

There are two workflows for directly importing JT files into Solid Edge. Both offer their own merits, depending on what you want to achieve. First 'interpart copy' (insert part copy) allows you to import a single JT file or assembly into a single Solid Edge part or sheet metal template. This method is beneficial when assembly structure and construction elements (surfaces and curves) are not as important as the overall geometry – for example, in mold tool design when you just need to subtract the JT data from a mold base. There are other useful options when you use 'interpart copy' to import JT files into Solid Edge that provide even more control, such as the ability to scale the design in the X, Y, Z direction, apply a shrink factor (mold tooling) and copy colors. You are also able to copy the design body or copy it as a construction body, choose a family of parts member (if one exists) or attach it to a coordinate system to further control placement within the Solid Edge file. As with the second method (opening a JT file



directly), interpart copies can be linked back to the original JT file to provide associativity.

The second method uses the Solid Edge 'File Open' command. By directly opening the JT file you are able to open single parts or assemblies into Solid Edge. A single part can be opened into a Solid Edge part/sheet metal file or as the initial part in a Solid Edge assembly. With this method, options for feature recognition are also available to add parametric features not included in the JT file.

JT files that contain multiple bodies and assembly structures can be opened directly into a Solid Edge assembly template, with all the relative component positions being

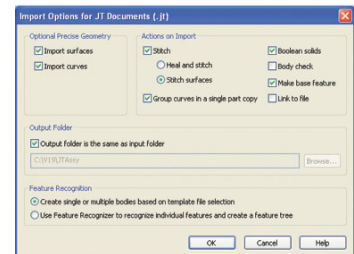

maintained and, if included, the assembly structure is maintained. JT files with multiple bodies can also be opened into Solid Edge part files, effectively creating a new part with all the bodies fused together into one new solid. The direct open method always imports solids if they are available, with further options to allow you to import any surfaces or curves that may be present.

Maintaining associativity

Whichever workflow you use to import JT files into Solid Edge, choosing the 'Link to File' option maintains associativity with the imported JT documents. This allows for an iterative design process when the original JT documents are constantly changing. Notification is provided when JT part data changes, with options to update the part document (note this is not supported in monolithic JT files). Associativity is maintained for both precise geometry and faceted bodies.

Best-in-class

JT provides best-in-class data format for design collaboration between customers and suppliers, with many options available in the workflow that:

- Protect intellectual property information
- Store JT data in a variety of formats
- Allow for an iterative design process

PMI – Improved design reviews

The American Society of Mechanical Engineers standard for 3D product definition (ASME Y14.41) legitimizes the use of 3D models for conveying product and manufacturing information (PMI). Siemens PLM Software has been a member of the Y14.41 committee since its inception, playing a key role in helping define the new standard.

PMI information in Solid Edge is in compliance with ASME and other world standards, supporting initiatives with global partners. Advanced 3D annotation tools mean PMI is captured and stored within Solid Edge 3D models and assemblies. These “smart” models reduce the need for drawings in design reviews and can be used for many downstream purposes, supporting lean initiatives and manufacturing. The inclusion of 3D product definition in a single digital file improves productivity, ensures the 3D information is accurate and in sync, and removes the need to keep multiple documents up-to-date.

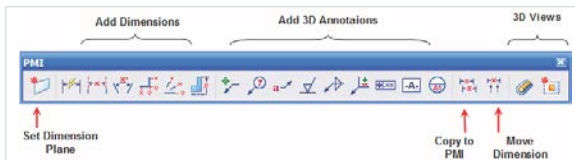

Solid Edge provides a full suite of tools for adding PMI data to your designs. The PMI toolbar provides a collection of tools for all your PMI requirements, including positioning PMI data, adding dimensions and 3D annotations, editing and a 3D section tool when additional clarity is required on internal components.

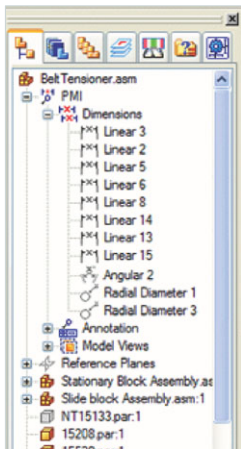

Solid Edge uses the intuitive SmartStep approach, which guides you through the process of adding PMI data to your models. Simply choose a plane to set the orientation for the PMI, and then choose the dimension or annotation type you require. Next select an edge, face or endpoint (or any other node) to snap to, where you want to position your annotations.

To provide efficient management and quick access when editing, Solid Edge collects all the PMI data in a separate entry in the Assembly and Part Feature Pathfinder under a top-level PMI node.

Adding dimensions to different D&A (dimension and annotation) planes coupled with the ability to add notes and annotations enable you to add complete PMI details to your 3D models. When you rotate the view the text stays on the plane. Text auto-rotates so that it is never upside down or displayed backwards. PMI dimensions and annotations can be printed from the 3D view if they are first displayed in your view.

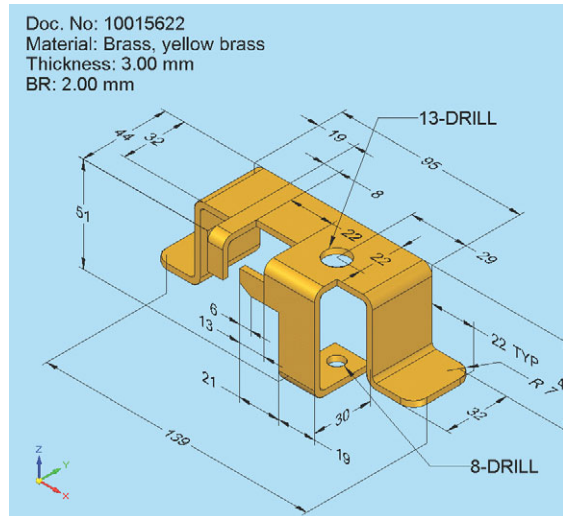

“PMI offers a good way to improve communication with technical departments such as the assembly line and shop floor. PMI allows us to better explain dimensions and texture with callouts. PMI reduces the number of drawings or eliminates the need for a drawing, which saves time. Intelligent 3D files can be sent for review.”

Olivier Pellerin
Project Manager
SEB

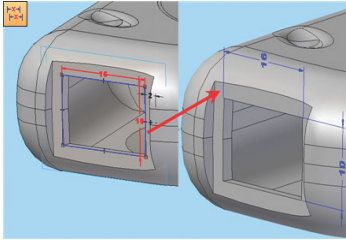

You can copy selected 2D sketch/profile dimensions and annotation objects and create equivalent PMI objects. All formatting and parameters of the selected dimension and annotation object are copied to the new PMI object (dimension style settings, tolerance, etc.)

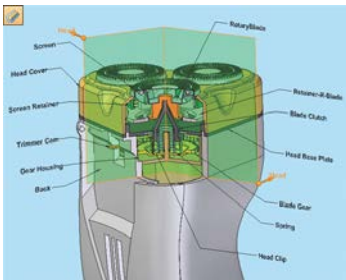

3D section views provide you with the ability to create a 3D section through your parts or assembly files. These can be used in conjunction with PMI to add information and clarity for internal components.

because PMI is supported in the Solid Edge free viewer, XpresReview and JT files, anyone with the relevant security access can see and use the information included in 3D files. No other vendor is offering this level of support.

As more and more companies need to collaborate and exchange data, PMI can reduce the amount of 2D drawings required and make them much easier to read. ANSI 14.41 allows the use of 3D models to transfer manufacturing information. Just like other commands in Solid Edge, PMI is intuitive and easy to use. Don't let this powerful new feature slip by you – discover the benefits of PMI in Solid Edge.

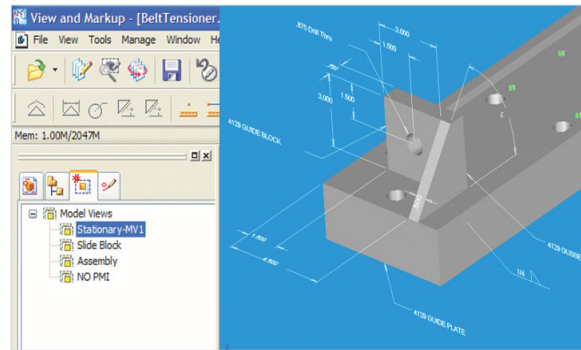

Send PMI to View and Markup

PMI provides seamless transfer to the Solid Edge View and Markup application. The files can also be viewed in Insight Connect, Teamcenter® software and the Solid Edge free viewer. The command will send all PMI in the document to Solid Edge View and Markup.

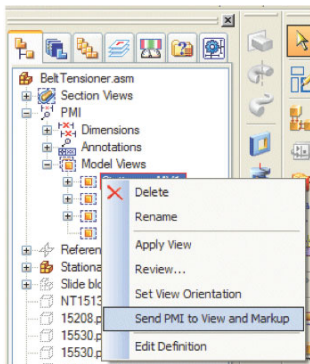

PMI can be viewed by shop floor assembly workers or maintenance engineers to reduce assembly time and serve as training aids, deliver better maintenance and support documentation with products. And

XpresReview

Fully supporting both JT and PMI data, XpresReview is a no-cost, easily downloadable electronic design review solution that allows companies to easily share multiple documents in a collaborative environment. XPresReview can be used independently with Solid Edge or NX unmanaged, or managed in conjunction with Insight or Teamcenter Express (v2.0).

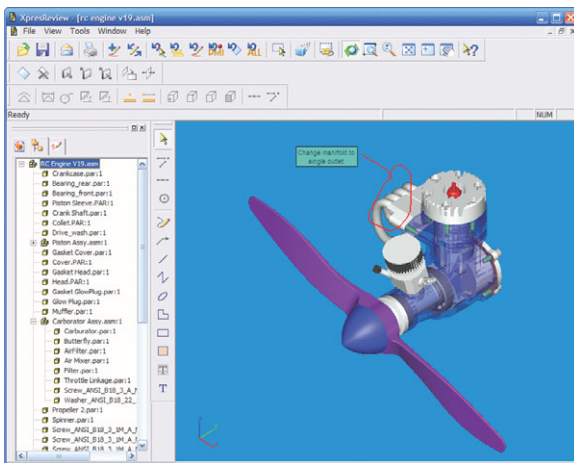

At the heart of and enabling the managed collaboration vision are packaged collaboration files (PCFs). PCFs elegantly solve the problem of how to share multiple documents, in a collaborative environment, while ensuring that users are never working with information that is out-of-date. Recipients of the package can use XpresReview to quickly and easily interrogate its contents – viewing, measuring and marking up the data.

A PCF is a portable, intelligent binder that contains lightweight representations of Solid Edge or NX CAD files, 2D drawings, Microsoft Word documents, Adobe PDFs, or virtually any other file and enables customers to conduct PLM processes such as sending a complete design review package or a supplier bid package with requirements, terms and conditions and schedules.

Package files, created using NX, Solid Edge or Insight Connect, can contain a broad range of documents, including:

- 3D models, including product manufacturing information (PMI)
- 2D drawings
- Microsoft Office documents (e.g. Word, Excel, PowerPoint)
- Adobe PDFs
- Image files (e.g. TIF, JPG, BMP)
- AVI movie files (e.g. AVI, MPEG, WMV)

The PCF container can be emailed to external users who do not use Insight or Teamcenter Express but who are involved in the review, markup and approval of design data. (For added security the author may also choose if the PCFs are for view only or if the recipient can also measure, view and markup). Rather than the cut-and-run approach of less sophisticated “email only” applications, the PCF retains original links to CAD documents in the managed database and contains all the information required to execute and manage any changes resulting from the collaborative process, including sending alert notifications of change to appropriate parties. External recipients can view, interrogate and redline documents within the PCF, and then the files can be repackaged for return to the originator or the next person in the review process, keeping your projects on time and avoiding late surprises.

Recipients of the package can use XpresReview to quickly and easily interrogate its contents. XpresReview includes intuitive tools for:

- Viewing – navigate 2D drawings and 3D models
- Measurements – check dimensions for 2D drawings and interrogate 3D models
- Markup – use highlights to draw attention to specific areas and add text comments
- Section views – create interactive clipping planes to view the interior of 3D models

The modified PCFs can be encapsulated back into Insight or Teamcenter Express when they are returned, ensuring that the most up-to-date information is available and everyone is notified.

For more information about XpresReview visit:
<https://www.plm.automation.siemens.com/forms/xpres.shtml>



XpresReview interface and features

XpresReview provides commands that allow you to change your display. The commands available depend on the type of file you are viewing. With 3D models, you can do such things as rotate, apply named views, zoom in or out on the model and create cross sections of the model. With 2D drawings, you can fit views, pan views, zoom in and out on views or rotate views. Once you have the display set the way you want it, you can add measurements, text markups or print it.

Full design interrogation (viewing)

XpresReview uses a structured interface that allows you to intuitively navigate around the PCF and provides neatly laid out tool sets that allow you to interrogate your design. XpresReview consists of command toolbars, XpresReview EdgeBar and a viewing window.

The top portion of the interface contains toolbars of commands you need to

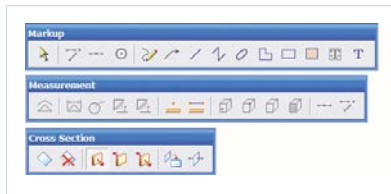

manage, view and markup documents. Access to the commands on these toolbars depends on the type of document that is open. For example, commands used to rotate a 2D image are not available for 3D documents. The XpresReview EdgeBar contains three nested tabs for:

- PCF contents
- Assembly PathFinder for convenient assembly structure navigation
- Various 2D and 3D markup tools

The PCF tab allows you to manage the package collaboration file, which contains a graphical representation of the active file, any markups made to the file, along with any other files that you may want to include, such as a Word document or Excel spreadsheet.

The tab displays a list of all files stored in the PCF. By default, the first file in the packing list is opened in the viewing window. All other files in the list are not graphically opened by default. You can select files in the packing list to display a preview image of the file.

You can right-click a PCF to display a shortcut menu that allows you to:

- Add documents to the PCF
- Delete documents from the PCF
- Manage the preview window
- Delete the file from the PCF

The Assembly PathFinder tab is available when you work in an assembly or a subassembly within the active assembly. It helps you work with the components that make up your assembly. It provides alternate ways to view the composition and arrangement of the assembly, besides looking at the graphics in the viewing window.

The Assembly PathFinder tab allows you to do such things as turn the display of assembly components on and off, and copy an assembly structure as text to the clipboard.

Measurement

XpresReview contains commands that allow you to add markups and measurements to your documents. The types of markups you can place depend on whether the active document is a 2D or 3D document. The originator of the PCF controls access to the various commands in XpresReview, so the availability of these commands may vary from file to file.



Dynamic sectioning

XpresReview provides tools that allow you to create and manipulate cross-section planes of a 3D model.

You can use the Create Section command to create the cross-section plane. The command allows you to specify the orientation of the cross-section plane to position the plane with respect to the X, Y and Z axes. After you create a cross-section plane, you can use the Position Plane command to move the cross-section plane around the model to display cross-sections at different locations in the model.

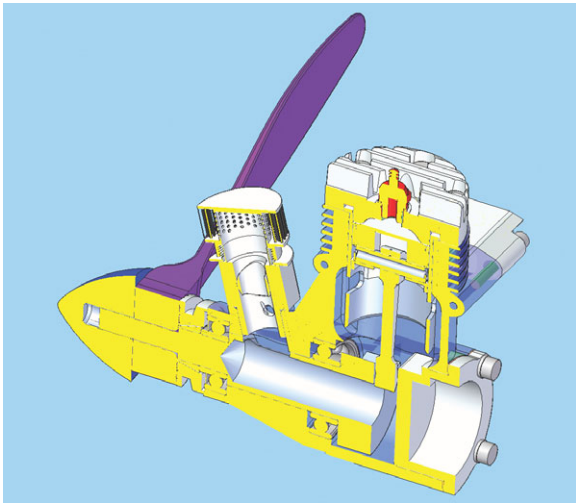

You can use a cross-section plane as a clipping plane. A clipping plane is a planar boundary that cuts away the objects it intersects, allowing you to view the interior of the model. Any part of the object that is on the other side of the clipping plane is not displayed. You can clip the near side of the plane, the far side of the plane or both sides of the plane.

You can use the Sectioning command to customize the appearance of cross-section planes to suit your needs. You can do such things as change colors and the width of lines and borders.

Text, annotation and redlining (Markup)

The Markup tab displays a list of markup groups for the PCF. A markup group contains a collection of markup objects. You can think of a markup group as a snapshot of everything the user has turned on, such as markups, measurements, sections, PMI and visibility of part. Initially, no markup groups exist for a PCF. When you create the first markup object, a new markup group is added to the tab. Click the top level markup group and click the Create New Markup button on the main toolbar to create additional markup groups.

Markup groups are based on a user name. In other words, each user who adds markups to the PCF will have their own markup group that cannot be modified by any other user. You can view and respond to the markup groups of other users, but you cannot edit them. If you respond to or create a markup while viewing another user's markups, a new markup group is automatically created.

Interoperability – Solid Edge, NX and I-deas

Translating geometric models of complex products is an imperfect, error-prone process that reduces the content and value of the information to the lowest common denominator. Repairing or recreating product data can impose uncertainties, errors and delays in progress from concept through manufacturing – delays that, in today's highly competitive marketplace, can mean the difference between winning and losing business.

With this in mind, software developers are continually working to break down the barriers of working with disparate data, with the result that three traditional levels of data exchange are commonly available.

- Intermediate translators that use a well defined standard to describe how to represent and exchange digital product information. The originating product saves a file into this standard, which is then accessed by a secondary translation process from the receiving product. Common examples of these standards include IGES, STEP and DXF. Most CAD products include one or all of these translators at no additional cost
- Direct translators that work in the background to allow one product to open native files from another without any visible intermediate step. These translators are often provided by third-party companies, who reverse-engineer a product's proprietary file format to gain access to the relevant data. They can be relatively expensive and are vulnerable from release to release due to changes that may occur in the source data structure
- Direct open technologies that allow products built on the same modeling kernel to exchange geometry without translation. The core modeling capabilities of Solid Edge and NX are built on the Parasolid modeling kernel. Developed by Siemens PLM Software, Parasolid is the world's leading production-proven component geometric modeling software, used as the geometry engine in hundreds of different CAD/CAM/CAE applications. Because of the Parasolid modeling core, users of Solid Edge and NX can readily exchange precise 3D geometric model data with more than a million seats of Parasolid-based applications without data translation

While each of these options is progressively better than the one before it, they do not solve the inherent problem of how to exchange native information between systems while still maintaining the full integrity of the original information. In other words the ability of one application to share disparate information with another in a manner that is non-destructive to any of the information being shared, whether it be geometry, structure, attributes or associativity.

Siemens PLM Software is the only company that can provide this level of interoperability.



Edit outsourced CAD data faster than the vendor who supplied it

Solid Edge with synchronous technology is the most complete feature-based 2D/3D CAD system available on the market today. It combines the speed and flexibility of direct modeling with precise control of dimension driven design, to provide the fastest, most flexible design experience possible. One key aspect of synchronous technology is the ability to edit feature – less imported geometry from other systems such as Inventor, Pro Engineer, SolidWorks, Co|create and more.



Most CAD systems can interchange data through neutral data exchange formats. The most common ones are JT, X_T, STEP and IGES. Simplifying the translation, some systems read CAD data directly, skipping the Save As step. However, that's where the simplicity ends. Because synchronous technology also works on featureless imported data, no system can work with imported data as effectively as Solid Edge. The same levels of edit

capabilities are available for imported models as for native files. Faces or complete face sets can be copied, moved, rotated or deleted. For precise control, dimensions can be used. Even though imported geometry is "dumb," meaning there are no stored relationships or features, Live Rules recognizes geometric relationships (tangency, concentricity, parallel etc.) within the geometry to ensure predictable edits. Procedural features can be added at will and the same synchronous solve technology manages the changes to any geometric element. Imagine adding dimensions between mounting holes in an imported model and, by entering the desired value, the correct hole spacing is obtained. Solid Edge with synchronous technology cuts through these barriers and lets you edit outsourced CAD data faster than the vendor who supplied it.

Fast edits begin with robust selection with or without a feature tree. A single selection tool for both 2D and 3D geometry allows you to choose elements, geometry or components without switching commands. Suggestive selection techniques in Solid Edge uses geometry recognition technology to infer the function you want to perform and can be used to find complex cutouts, bosses or ribs automatically, directly from the geometry. Results can be saved as user-defined features to be re-used later if desired.

"Synchronous technology breaks through the architectural barrier inherent in a history-based modeling system."

Dr. Ken Versprille
PLM Research Director
CPDA

Solid Edge provides the unique ability to detach and attach selected geometry simplifies complex edits. You are able to cut complex sections of geometry, add new features or make changes to the existing model, then simply paste the detached geometry back to complete the edit. While this technique works on either native or imported data, the intelligence happens during the attach process in that geometry adapts to the model and rounds reblend along any newly created edges. This capability greatly simplifies making complex edits to imported geometry; it further eliminates the need to preplan designs.

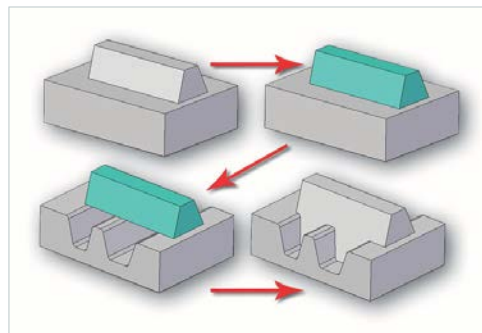

Using NX data in Solid Edge

An application for Solid Edge utilizing NX parts is in downstream tooling processes. Solid Edge is used for the creation of jigs and fixtures, like this one developed for an automated welding process.

Solid Edge powerful assembly design tools are used to build components around the NX part – using unique systems design capabilities to ensure accurate fit and function of the welding fixture before any parts are manufactured.

Solid Edge provides users with the ability to access the NX part without any translation. As a result, tooling work can be carried out in parallel with product design and part notification for updates to all team members; and the fixture can be changed accordingly without having to start from scratch.

Using Solid Edge helps you recognize and work with NX parts and assemblies, automatically generating the correct data, even though both types of file have the same extension (.PRT) in NX. Both solid and sheet bodies can be utilized, even when a file contains multiple solid bodies, and the NX designer can define which geometry will be transferred to Solid Edge.

Delphi Corp. case study

Manufacturing engineers at Delphi Corp. Energy and Chassis Systems Division use Solid Edge to open 3D product geometry (NX models) directly into their CAD software. They either access the product data directly using Delphi's corporate product lifecycle management (PLM) system, based on Teamcenter Engineering or have it sent via the Delphi network from the product designers. Opening product geometry directly is 50 to 80 percent faster than the previous method that required data translation from 3D to 2D. It is also highly accurate because the product designer's model data is used directly in Solid Edge. Because the previously non-associative 2D tool designs are now associative in Solid Edge, similar savings occur each time there is a product change that results in a tool change. In addition to using NX product data into Solid Edge, machine designers can directly incorporate NX machine models and assemblies into their Solid Edge assembly. This makes it possible to utilize data from those suppliers that use NX for machine design.

For NX assemblies, Solid Edge will recreate the assembly structure – occurrence names, colors, file names – even when the original assembly files do not reside in the same folder. The level of interoperability is such that Solid Edge can find the NX part files related to a given assembly and recreate an accurate view of the assembly.

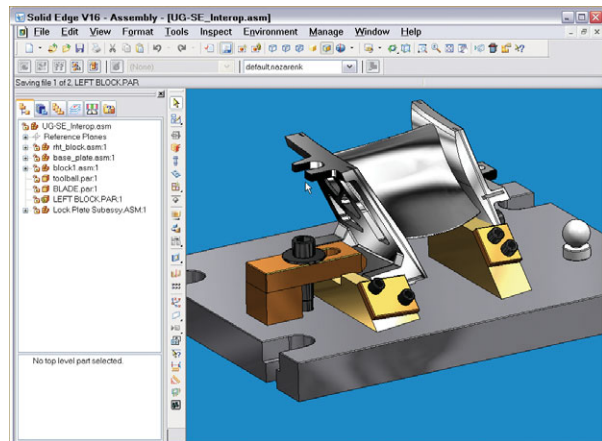

The NX files present in the Solid Edge assembly will remain associative back to the NX application, and can still be opened and worked on. If the original part is modified, Solid Edge will clearly show that the geometry is out-of-date with respect to the original, and the user can update as necessary. This can be either a manual or automatic process.

Because synchronous technology works directly on 3D geometry you are able to use Solid Edge with synchronous technology edit 3D files that were originally designed in NX.

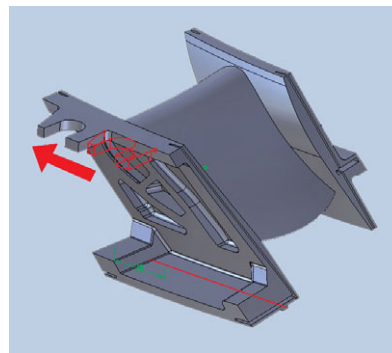

NX model, direct edits carried out in Solid Edge.

Conclusion

Interoperability is a core vision for Siemens PLM Software, and one that has been proven in production to eliminate waste and shorten the process of change. Some of this waste is obvious, such as time and money spent on intermediate translation files and checking for inaccuracies. Others are not so obvious. Immediate and accurate access to data leads to faster design reviews between departments, customers and suppliers. Siemens customers can leverage intellectual capital created with either NX or Solid Edge and suppliers can win more business by demonstrating their ability to utilize native data from the system their customer is using, and comfortably manage any downstream changes.

And, whether you use NX, Solid Edge or both, you enjoy the direct benefits of a dual product strategy. Both products share continual advances in innovation, while providing access to the best and most relevant technology for your business for now and the future.

“Design time is reduced by at least half because we have the critical data from the original NX native part files. And the calls from the manufacturing floor, reporting design errors, have dropped to zero.”

Richard Pickering
Senior Product Design Engineer
Q3 Industries

Design collaboration across all points of the value chain

With Solid Edge, organizations can implement a cost-effective collaborative design solution throughout their entire value chain – while enjoying the advantage of single-source support from the PLM leader – Siemens PLM Software. These essential design and collaboration capabilities enable OEMs and suppliers to transform their process of innovation and get on a fast track to the strategic benefits offered by PLM.

About Siemens PLM Software

Siemens PLM Software, a business unit of the Siemens Industry Automation Division, is a leading global provider of product lifecycle management (PLM) software and services with 7 million licensed seats and more than 71,000 customers worldwide. Headquartered in Plano, Texas, Siemens PLM Software works collaboratively with companies to deliver open solutions that help them turn more ideas into successful products. For more information on Siemens PLM Software products and services, visit www.siemens.com/plm.

www.siemens.com/plm

All rights reserved. Siemens and the Siemens logo are registered trademarks of Siemens AG. D-Cubed, Femap, Geolus, GO PLM, I-deas, Insight, JT, NX, Parasolid, Solid Edge, Teamcenter, Tecnomatix and Velocity Series are trademarks or registered trademarks of Siemens Product Lifecycle Management Software Inc. or its subsidiaries in the United States and in other countries. All other logos, trademarks, registered trademarks or service marks used herein are the property of their respective holders.

© 2012 Siemens Product Lifecycle Management Software Inc.

X7 10202 1/12 C

Siemens Industry Software

Americas

+1 800 807 2200

Fax +1 314 264 8922

Europe

+44 (0) 1202 243455

Fax +44 (0) 1202 243465

Asia-Pacific

+852 2230 3308

Fax +852 2230 3210