

NX for Tooling and Fixture Design

Transforming today's processes for designing and manufacturing injection molds, dies and fixtures

Benefits

- Accelerates design-to-manufacture job turnaround by reducing design lead time, minimizing manufacturing and machining time and cutting design change time/effort
- Reduces tool cost by enabling tooling companies to understand the cost to manufacture, eliminating both human and design errors and removing traditional cross-discipline disconnects
- Improves tool design quality by enabling tooling companies to achieve first-time quality on increasingly complex parts
- Improves NC programming time by facilitating faster toolpaths
- Reduces machining time by enabling tool designers to implement high-speed machining processes that decrease electrode manufacturing, as well as reducing total mold manufacturing time
- Improves quoting accuracy by enabling tooling companies to deliver faster more informative and more accurate quotes to their customers

Summary

The NX™ software for Tooling and Fixture Design provides tooling companies with a series of tiered solutions for automating and improving their mold, die and fixture design and manufacturing processes. NX enables toolmakers to reduce their design-to-manufacture cycle time, improve first-time product quality and minimize cost to manufacture. Ultimately, you can use NX to enable tool designers to seamlessly work with product and part designers, manufacturing engineers and NC programmers in a fully integrated part manufacturing environment.

NX provides a series of tiered solutions that tooling companies of all sizes can use to seamlessly establish the right level of tool and fixture design capabilities for their operations. You can start with a tooling design solution that addresses your mold, progressive die, stamping die and fixture design requirements. Or you can expand this solution with CAM integration, as well as engineering process management capabilities, in step-by-step increments or in a single integrated deployment at your discretion.

Ultimately, you can use NX to enable all of the disciplines that participate in a tool design through production process to work seamlessly together.

NX provides the following tooling and fixture design solutions founded on the comprehensive NX technologies that deliver advanced design, simulation and manufacturing solutions:

- *Fixture Design solution*, which enables you to rapidly design, configure and simulate the most complicated fixtures
- *Tool Design solution*, which enables you to automate and manage your mold, progressive die and stamping die design processes

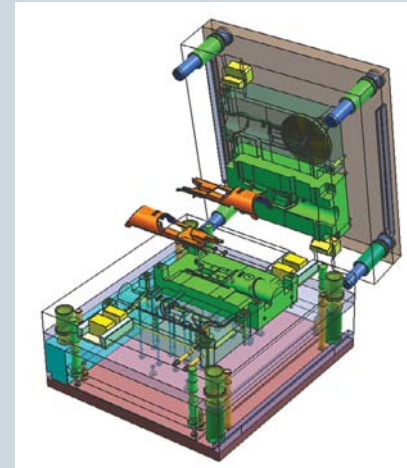

NX accelerates mold design through its automation capabilities and embedded process expertise.

NX

NX for Tooling and Fixture Design

Benefits *continued*

- Improves entire tool design process by reducing new product time-to-market
- Improves teamwork across the entire part manufacturing process by facilitating early validation from engineering and manufacturing, tight supply chain integration and regional implementation of global processes

Features

- Comprehensive mold design
 - Mold base design capabilities, including out-of-the-box standard parts and mold base libraries, easy to define and easy to re-use standards presented in spreadsheets and a standard parts registration wizard
 - Core/cavity design capabilities, including tools for quickly designing shut-offs, parting lines and core/cavity split, as well as for automating parting surface design
 - Molded part validation for product design validation and interference clearance checking tools
- Progressive die design
 - Part preparation for simple and complex parts, including one-step unforming and formability analysis and direct unforming for straight break parts
 - Process design capabilities, including tools for design nests, scrap and strip layout
 - Die structure design capabilities, including standard parts, insert groups and die base libraries

- *Tool Design and CAM Integration solution*, which enables tool designers to work in the same environment as manufacturing engineers and NC programmers, thereby eliminating the inefficiencies that arise as your tool designs move to machining and manufacturing
- *Tool Design, CAM Integration and Engineering Process Management solution*, which enables your tool designers to participate in a comprehensive part manufacturing environment that includes product and part designers as well as manufacturing engineers and NC programmers

Today's tooling and fixture design challenges

Tooling companies of all sizes are driven by the need to perform "better-faster-cheaper" in a highly complex marketplace characterized by global competition. Toolmakers are expected to reduce their cycle times by compressing the process required to design and manufacture their tools. Minimizing design lead time and reducing manufacturing, machining, and design time are crucial to these efforts.

Equally important, tooling companies are pressured to reduce tool cost by eliminating both human and design errors, and removing rework and inefficiencies from their processes. At the same time, toolmakers understand the importance of achieving first-time quality even while they are required to accommodate increasingly more complex parts.

These demands are compounded by the need for toolmakers to participate in widely dispersed supply chains, where teamwork, tight communication, continual alignment of design intent and the need to integrate disparate technology is extremely important.

NX state-of-the-art tooling and fixture design solutions

NX injection mold, progressive die, stamping die and fixture design capabilities are built on comprehensive NX modeling, assembling modeling and drafting technology. NX technology enables you to develop effective tool

designs faster and with fewer errors and corrections. NX represents a radical departure from conventional tooling design systems.

NX provides a powerful set of automated capabilities for mold and die design. NX enables users to complete the task of moving from part design to finished tool design in far less time than traditional CAD applications.

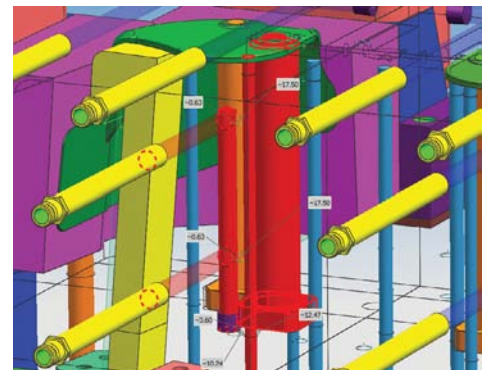

You can leverage NX to avoid interferences and validate your designs for proper clearances.

NX improves speed and efficiency while eliminating wasted work by providing unique technologies and methodologies, including:

Knowledge-enabled design NX automates and simplifies design by enabling you to leverage the part, tool and process knowledge that your company has gained from its experiences as well as from industry best practices. NX enables designers to capture knowledge in the form of wizards, company standards, templates, frequently used design features, engineering rules, formulae and validation checks. Knowledge-enabled design helps your company reduce design costs, compress the design cycle and improve design quality.

You can manage your entire design process with Siemens' Teamcenter® software, which lets you establish and seamlessly integrate a single source of

Features *continued*

- Stamping die design
 - Ability to determine formability-related issues early in the design cycle
 - Process design capabilities, including die face, die lineup and detailed die structure
 - Detailed analysis and optimization of the full press line
- CAM integration capabilities, including CAM automation from tool design and feature-based machining
- Electrode design capabilities, including tools for expediting the design, validation, documentation and manufacturing phases of the entire EMD process
- Engineering process management capabilities, including Teamcenter capabilities for knowledge management, requirements management, revision control, change management and visualization
- Extendable Teamcenter capabilities for community collaboration, program and project management and advanced BOM/BOP

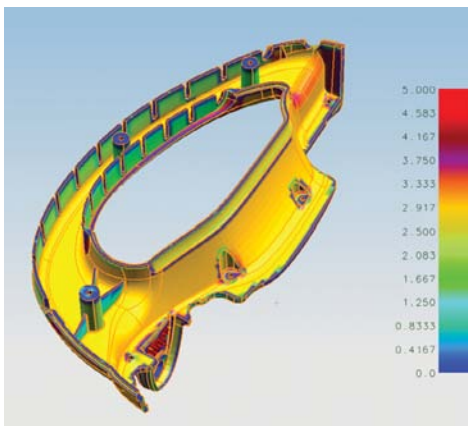

You can use NX to validate molded part manufacturability by analyzing draft and wall thickness.

product, part, tool and process knowledge into your design environment. This enables you to coordinate your design chain, standardize your design processes and accelerate decision making throughout the design cycle.

Process innovation NX tooling design solutions come out-of-the-box equipped with embedded process expertise. As a result, these NX solutions are not ordinary CAD applications but solutions that include predefined and streamlined processes with features for designing molds. These processes enable less experienced designers to be more productive. They also shorten tool design time, reduce errors and increase tool design repeatability.

NX also includes design validation features to ensure that your parts, tools and manufacturing processes have been properly defined to eliminate costly physical rework. Special NX features enable you to identify common problems and errors faced throughout your design and manufacturing processes.

More specifically, NX addresses the tooling and fixture design process directly through its:

- Tier 1 solution for tool design
- Tier 2 solution for tool design and CAM integration
- Tier 3 solution tool design, CAM integration and engineering process management

Tier 1 solution

NX provides a tier 1 solution for tool design that enables you to automate and optimize your mold, progressive die, stamping die and fixture design processes.

Mold design NX provides design validation features to enable users to analyze a part for manufacturability and automatically generate information about its draft angles, undercut areas and sharp corners (all of which determine whether a part is difficult or impossible to mold) – as well as check the tool design for interferences. NX optimizes core/cavity design by enabling users to automate parting surface design and quickly design shut-offs, parting lines and the core/cavity split. NX

streamlines mold base design by providing out-of-the-box standard parts and mold base libraries, easy to define and easy to re-use standards-based spreadsheets and a standard parts registration wizard.

Progressive die design NX guides users through all of the stages required to construct a progressive die, automating the most tedious tasks and streamlining the most complex processes. To expedite part preparation, NX provides a one-step process for validating formability and creating unformed and blank profiles for complex freeform parts. NX streamlines the preparation of straight break parts through feature recognition and a process for defining prebends and overbends. NX improves die structure design by enabling users to work with standard parts, insert groups and die base libraries. In addition, NX provides special process design features to nest designs, minimize scrap and lay out strips.

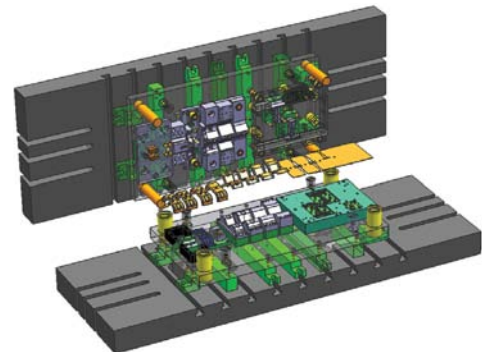

NX enables you to capture and re-use design knowledge to speed progressive die design.

Stamping die design NX provides a single solution for designing stamping dies that includes capabilities for formability analysis, die planning, die face design, detailed die structure design and die validation. NX enables you to design dies by leveraging built-in best practices. NX can generate detailed process models for each station of the press line. NX determines the areas of the part to be formed, flanged, trimmed, the location of the holes and then tips the part into the die position.

You can easily create additional geometry needed in the draw stage for binder and addendum. NX compensates for springback by utilizing surface deformation functionalities such as overcrown, overbend and wall deformation. And finally, you can use NX to automate the creation of detailed die structures.

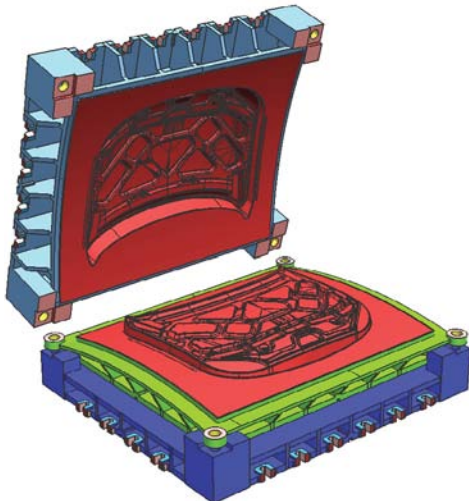

NX stamping die design solution enables you to leverage built-in best practices.

Fixture design NX enables you to design fully associative fixtures that rapidly and accurately update to product model changes. You can leverage the power of NX Assemblies to position and mate components within a design context. Your designers can store and easily access commonly used components by employing NX knowledge libraries. NX kinematic



You can use NX fixture design capabilities to verify fixture performance in various positions and arrangements.

Image courtesy of J.S. McNamara Inc.

simulation tools enable you to display and check mechanism motion. You can validate performance by visualizing multiple fixture arrangements under different conditions, including open and closed positions.

Tier 2 solution

You can add NX CAM integration capabilities to your tier 1 tool design solution to enable your tool designers to seamlessly work with manufacturing engineers and NC programmers in a single integrated environment.

CAM integration NX allows tool designers to seamlessly move their tool designs to the CAM phase of the part manufacturing process. NX eliminates the need for data translations, enabling the tool design, machining and manufacturing disciplines to share information through a process that is both faster and more efficient. Design changes can be implemented more easily and with fewer errors since NX maintains associativity between your tool designs and the CAM process. Equally important, NX facilitates concurrent design and manufacturing by enabling these disciplines to take advantage of a single geometry master.

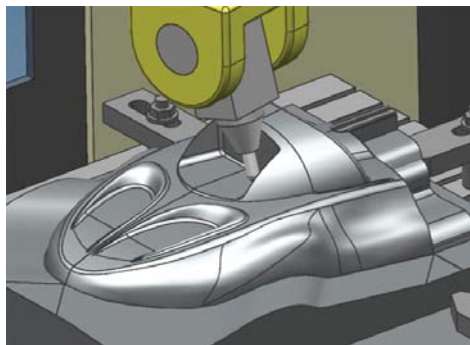

You can integrate NX CAM into your solution to facilitate high-speed machining and automation of your downstream manufacturing definition.

Electrode Design NX enables you to integrate the process used to model and design electrodes of any tool project that requires electrode discharge machining (EDM) into your integrated tool design and CAM extended environment. NX incorporates numerous industry best

practices and automated processes into these electrode design capabilities. These enhancements enable you to manage the most complex and challenging electrode designs using a time-saving, step-by-step approach that automates the design, validation, documentation and manufacturing phases of the entire EDM process.

Tier 3 solution

You can extend your tier 2 solution with engineering process management to enable your tool designers to work in a comprehensive part manufacturing environment. This environment enables product and part designers, as well as manufacturing engineers and NC programmers, to share their product and part definitions and align both the upstream and downstream processes in a product lifecycle.

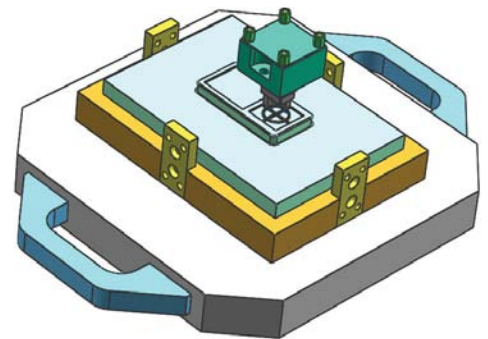

You can achieve associative electrode design with NX Electrode Design, a process-based add-on application.

Engineering process management NX leverages Teamcenter engineering process management capabilities to enable all of the participants in the part manufacturing process to align their work and synchronize their job tasks. Engineering process management enables you to bring all of your product, part, tool design, manufacturing engineering and CAM data in to a single source of knowledge. You can drive all of downstream processes off the master geometry model.

You can establish concurrent design processes to enable tool designers, NC programmers and manufacturing engineers to begin their work even before product and part designs are complete. You can establish revisions and intermediate versions controls over all of this information. You can leverage standards-based processes to initiate, review, approve and execute design changes. And you can use JT™ visualization capabilities to enable multiple participants in the part manufacturing process to share the same 3D data.

Other Teamcenter extensions You can extend any of your tiered solutions with three key Teamcenter capabilities:

- Teamcenter community collaboration capabilities enable multidisciplinary teams to share and track rich product, process, tool design, machining and manufacturing data. Your tool designers can work with your suppliers, allied partners and trusted customers in a collaborative community that facilitates concept studies, program reviews, design reviews and engineering change reviews.

- Teamcenter manufacturing process management capabilities enable companies to manage manufacturing data, process, resource and plant knowledge in the same environment they use for product, part and tool development. You can use Teamcenter advanced BOM/BOP management capabilities to associatively relate essential bill of material (BOM) information with the manufacturing bill of process (BOP). A comprehensive part management environment can leverage this associativity and Teamcenter configuration management capabilities to represent the physical decompositions of all activities related to manufacturing assembly. This approach makes certain that all disciplines are using the right product configurations in the right working context.

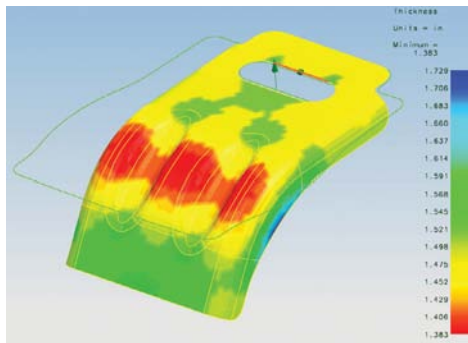

NX enables you to perform one-step formability analysis to verify sheet metal manufacturability.

Contact
Siemens PLM Software
Americas 800 498 5351
Europe 44 (0) 1276 702000
Asia-Pacific 852 2230 3333

www.siemens.com/nx

© 2011 Siemens Product Lifecycle Management Software Inc. All rights reserved. Siemens and the Siemens logo are registered trademarks of Siemens AG. D-Cubed, Femap, Geolus, GO PLM, I-deas, Insight, JT, NX, Parasolid, Solid Edge, Teamcenter, Tecnomatix and Velocity Series are trademarks or registered trademarks of Siemens Product Lifecycle Management Software Inc. or its subsidiaries in the United States and in other countries. All other logos, trademarks, registered trademarks or service marks used herein are the property of their respective holders.
X5 14546 4/11 B