



SIEMENS

www.siemens.com/nx

NX Tooling

NX software delivers advanced automation, process simulation and integrated technology to improve productivity and ensure first-time quality in tooling development.

www.siemens.com/plm

The demand for speed

Tool design and manufacture is on the critical path for the development of many products. The demand for much shorter product delivery times, faster turnaround on design enhancements, lower supplier costs and increasing global competition have dramatic impacts on the toolmaking business.

The need for skills

The complexity of tool design and manufacture traditionally requires highly skilled people applying knowledge learned over years of practice. These resources are difficult to obtain or replace. Companies can gain competitive advantage by effectively leveraging specialized, best-practice knowledge in tooling development.

Improving quality

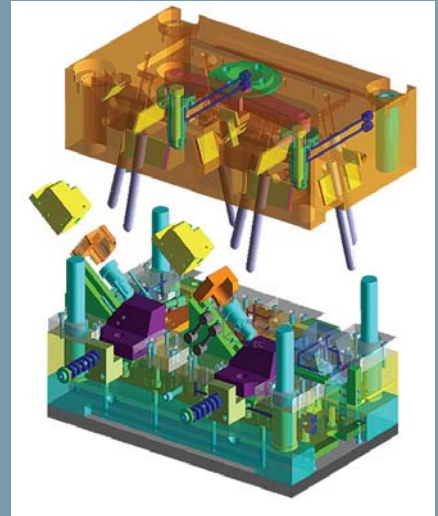
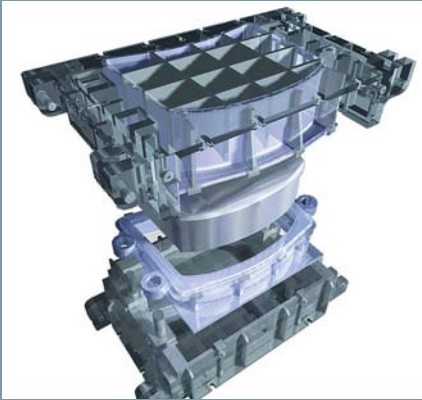
Quality of the end product depends directly on high-quality tooling. To achieve quality, tool designers and manufacturers must integrate their work with the product development effort. By dynamically linking tooling designs with product designs, companies can automatically propagate design changes to production tooling, achieving first-time quality.

Reducing waste

To achieve speed and cost objectives, tool designers and manufacturers must eliminate wasted time, effort and resources – not only between product development and tooling development, but also throughout the tooling design, optimization and manufacturing process.

Transforming the process

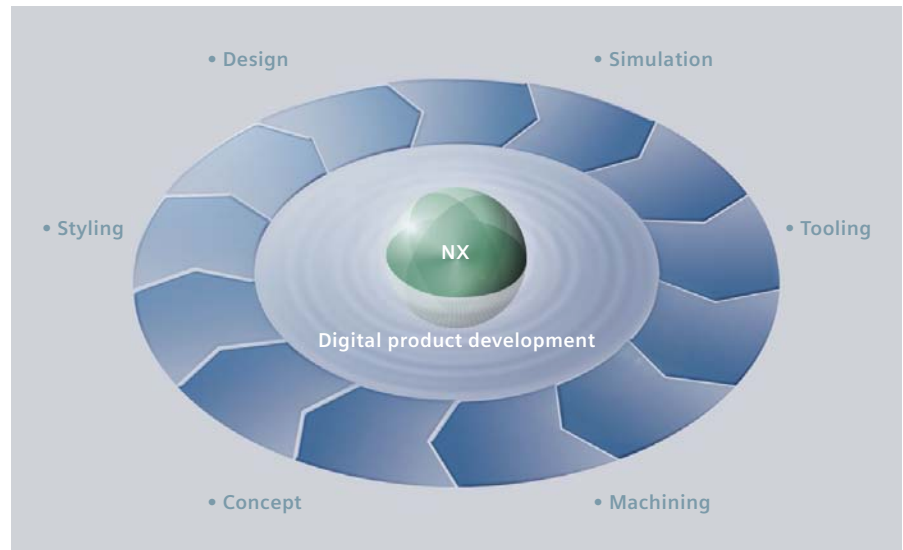
NX™ software from Siemens PLM Software is a next-generation solution that transforms the tooling development process with advanced automation. Knowledge-driven applications for tooling design and manufacturing are fully integrated with the overall product development process in a managed environment that improves productivity, accelerates the process, reduces waste and cost and improves quality.



The NX Tooling advantage

A complete solution

With NX, tool designers can share the same software environment as product and part designers and NC programmers. This enables the overall process to be faster and more efficient. Changes can be implemented more easily and with fewer errors. Wasteful re-entry of data is eliminated and multiple users can share the same 3D data. The tool designer, NC programmer and manufacturing engineer can begin work even before the product design is complete.



Highly automated tool design

NX offers a powerful set of automated applications for mold and die design. These applications enable the user to complete the task of moving from part design to finished tool design in far less time than with the use of traditional CAD applications.

Maximizing productivity

Mold and die tool design in NX is driven by the knowledge of experienced designers built into the functions. The applications guide the user through each step of the process, multiplying the capability and maximizing the productivity of every tool designer.

Based on the premier foundation

The NX applications for injection mold, progressive dies and transfer dies are built on the comprehensive NX design software. This means that the very best in modeling, assembly modeling and drafting technology is providing the foundation for these high-performance applications.

Delivering business efficiency

NX Tooling delivers a much higher level of business efficiency, leading to reduced cost, increased activity and higher margins. It helps achieve these results by developing effective tool designs faster and with fewer errors and corrections.

Working with other systems

At the core of NX is the Siemens Parasolid® software modeling foundation, an industry standard in 3D modeling technology developed by Siemens PLM Software and widely used in CAD/CAM and CAE applications. This foundation provides unmatched compatibility for working with 3D data.

In addition to reading Parasolid geometry, NX can use a wide range of data from other CAD systems in their native formats and translate a variety of other formats with data conversion tools.

In fact, NX tool design applications can work with almost any type of 3D input data. NX makes it easy to build 3D models from 2D drawing data.

Automated mold design with NX Mold Wizard

NX Mold Wizard applies Process Wizard technology to optimize the mold design process, delivering levels of productivity that dramatically outperform traditional CAD software. Providing a structured workflow based on expert best practices, automation of mold-specific design tasks and libraries of standard mold components, NX Mold Wizard provides a step-by-step process that promotes the most efficient workflow, while integrating complex elements of design technology into automated sequences.

Mold Wizard is built on NX, the industry's most powerful product development system. As a result, the tools for working with part geometry, creating parting surfaces and enabling automatic updates are among the most robust available. Less capable systems may handle basic parts and molds, but Mold Wizard can tackle the most demanding tasks.

Stepping through the process with NX Mold Wizard

At each stage the power of NX adds value, making the task easier, the mold better and the job faster.



NX mold design: key features

Some key capabilities in NX Mold Wizard

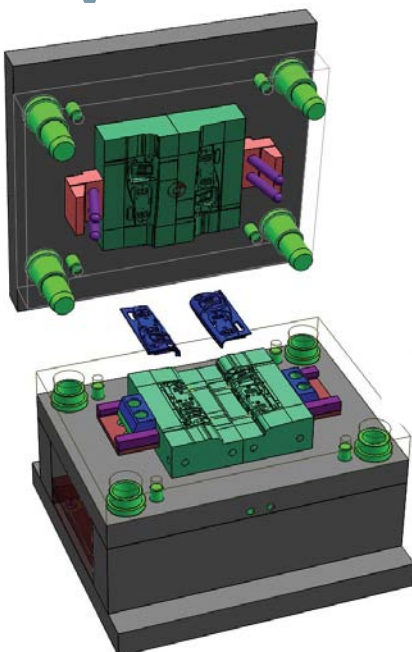
- Full NX part design capability for "one-stop" customers
- Comprehensive data import, with translators or native format read to bring in third-party design files
- Manufacturability checking for molded parts
- Advanced parting tools driven by the power of NX
- Automatic core and cavity insert creation
- Model swap for automatic updates, compare new versions
- Shrinkage calculation and adjustment
- Mold base and standard part catalogs
- Ejector pin post, sliders and lifters
- Cooling layout, tubes and fittings
- Automatic bill of material (BOM) creation
- Automatic drawing creation where required



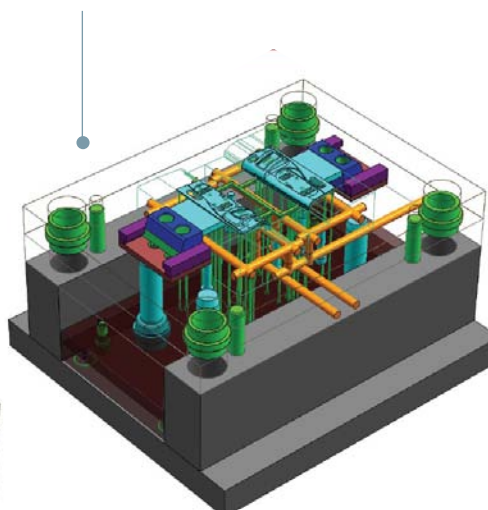
NX Mold Wizard includes a structured series of commands for all tasks in the mold design process.



Libraries of standard mold bases and components accelerate modeling of the complete mold assembly, including lifters and risers.



NX provides a catalog of standard cooling components that is flexible and customizable.

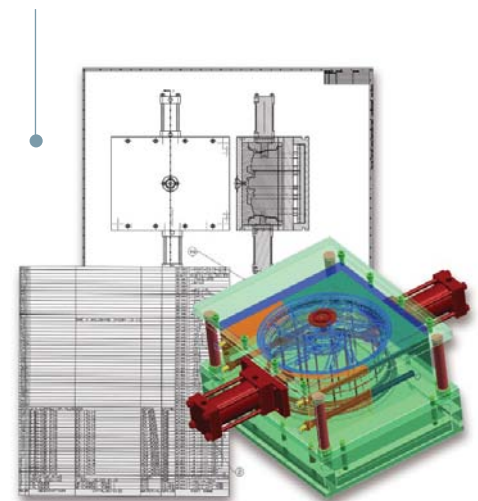


Proven results

"Siemens' NX is one of the most established and reliable 3D CAD/CAM solutions available today. It helps us make changes faster and reduce errors."

Shen Zhi Gang
Assistant Engineering Manager
Omni Mold

NX accelerates mold manufacturing by documenting the mold design with automated drawing and bill of materials creation.



Molded part validation

Can the part be molded?

The sooner a design is checked for manufacturability the sooner problems can be fixed. NX design validation tools enable the user to analyze the part and automatically obtain information about draft angles, undercut areas and sharp corners – elements that would make the part impossible or difficult to mold.

NX can also provide the designer with an easy visual check of core and cavity sides that doesn't require any special analysis or knowledge of mold design. By catching problems early, designers can avoid the wasted time and effort that occurs when the tooling department or supplier discovers that a part can't be molded as designed.



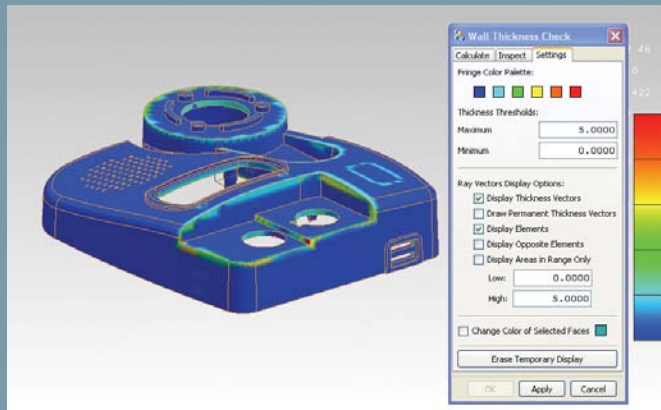
Toward Six Sigma

Using NX Mold Wizard, The Tech Group not only achieved a 20 to 25 percent gain in productivity but also achieved a 50 to 75 percent gain in quality.

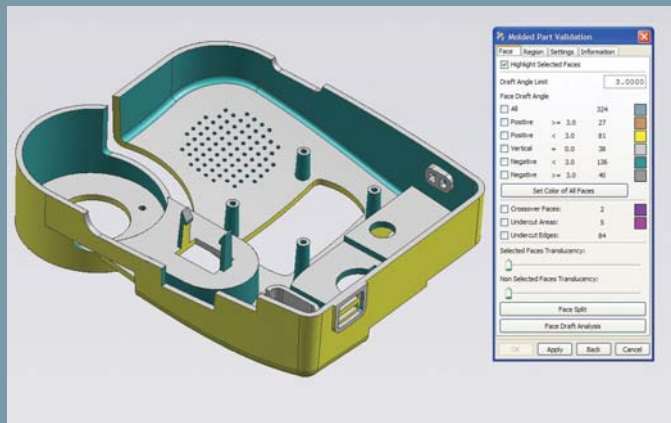
The company believes that NX Mold Wizard's contribution to automation, accuracy and consistency will help them achieve Six Sigma goals.

Molded part validation

- Wall thickness check
- Draft angle display
- Plastic feature check (corner radius, feature distance, etc.)
- Find manufacturing features
- Colored region-based parting line definition



NX validates molded parts by checking wall thickness. Results are displayed in easily interpreted color-coded areas on the part model.



NX ensures part and tooling design quality by evaluating draft angles, undercuts and crossover faces that affect moldability.

Mold design to manufacture

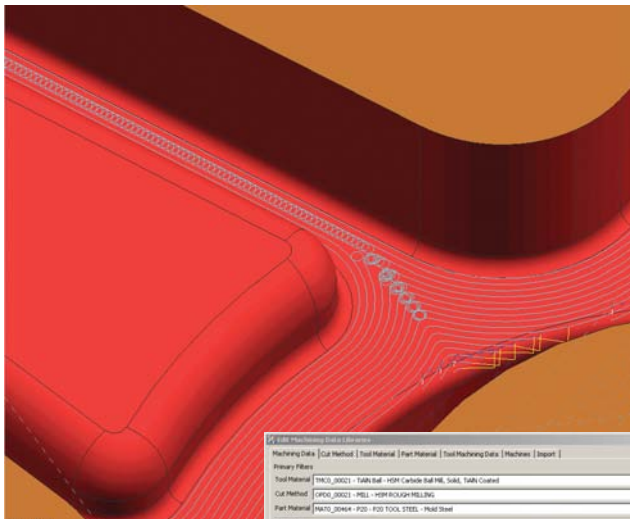
Design and machine the mold in NX

Not only does NX offer Mold Wizard to design the complete mold assembly, NX also offers an excellent NC programming solution to set up the machining of mold faces and mold structure components.

Feature data added to the model by Mold Wizard can be read directly by NX Machining. This makes the process of transferring information to the NC programmer much faster and more accurate.

When part and tool revisions occur, it's easy to see the areas changed and to update toolpaths. Because NX includes both design and manufacturing capabilities, the NX programmer can begin before the mold design is completed.

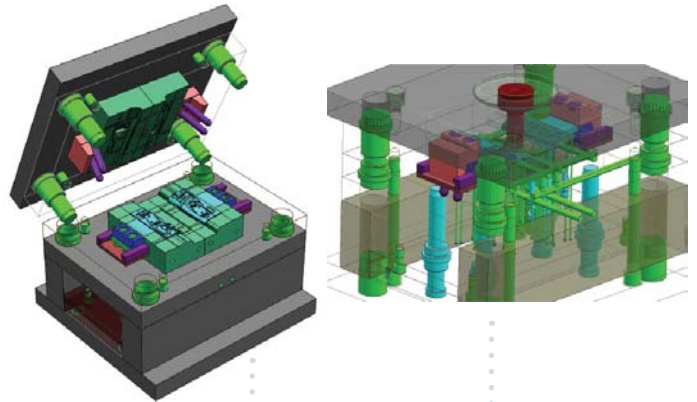
> All in NX



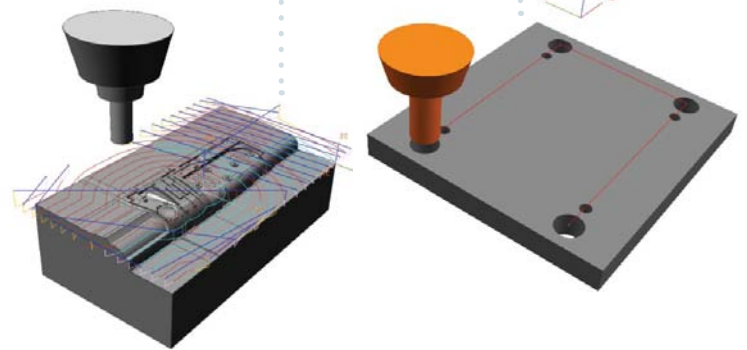
NX offers advanced toolpath technologies for mold and die machining, including automatically invoked trochoidal toolpaths that effectively reduce tool loading.

Machining Feature	Operation	Length	Cut Depth	Strokes	Surface Speed	Feed per Tooth	Approach %
THRO_00206	1.0000	0.0000	0.2000	0.2000	60.0000	0.0200	0
THRO_00207	2.0000	0.0000	0.1000	0.3000	60.0000	0.0400	0
THRO_00208	3.0000	0.0000	0.2000	0.4000	110.0000	0.0700	0
THRO_00209	4.0000	0.0000	0.3000	0.6000	160.0000	0.1200	0
THRO_00210	5.0000	0.0000	0.5000	0.8000	180.0000	0.1500	0
THRO_00211	6.0000	0.0000	0.6000	1.0000	220.0000	0.1900	0
THRO_00212	8.0000	0.0000	0.8000	1.4000	220.0000	0.1900	0
THRO_00213	10.0000	0.0000	1.0000	1.8000	220.0000	0.1900	0
THRO_00214	12.0000	0.0000	1.2000	2.4000	240.0000	0.1900	0
THRO_00215	14.0000	0.0000	1.4000	2.7000	240.0000	0.1900	0

Mold design



Mold machining



High-speed machining in NX

NX Machining offers excellent NC toolpath generation for mold and die manufacture. Key capabilities are provided for high-speed machining or hard milling, applying special toolpaths and optimum cutting parameters. These allow users to maximize the productivity of their high-performance machine tools.

Automated feature-based programming is ideal for mold base machining. Feature-based hole-making automatically recognizes holes in mold plates, sorts them by size and type and creates optimized toolpaths that minimize tool changes and cycle time.

> Value added in mold design, multiplied in manufacture

Progressive die design

NX Progressive Die Wizard maximizes productivity through intelligent automation of industry-specific processes. Beginning with the receipt of the customer's sheet metal design, NX Progressive Die Wizard guides the user through all of the stages required to construct a progressive die, streamlining complex processes and automating tedious tasks for remarkable time savings.

Progressive Die Wizard functions for blank creation, blank layout, scrap design and strip layout support a range of progressive die designs including multiple sheet metal parts, multiple rows, multiple strip layouts and custom strip layouts.

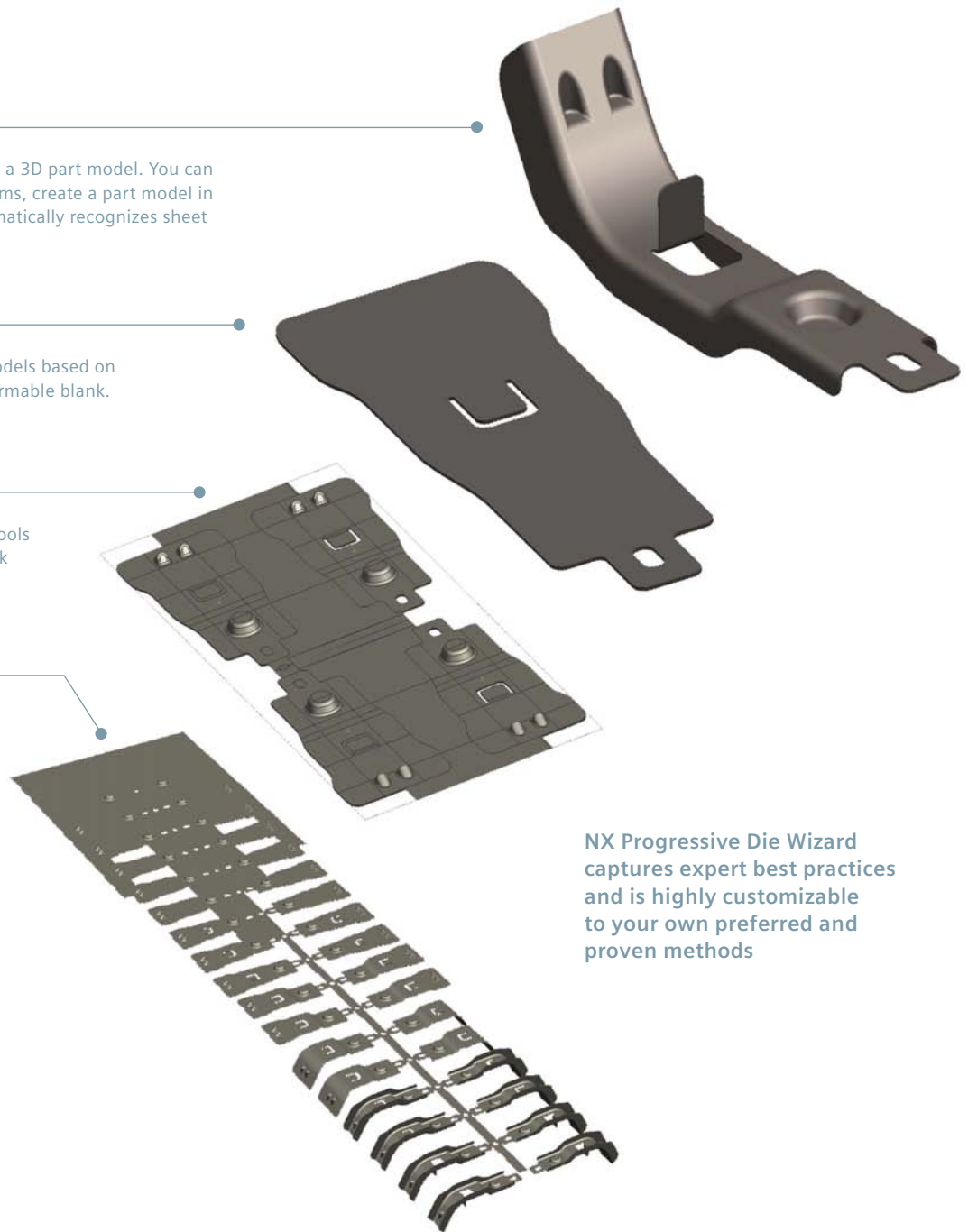
Phase 1: Process design

Progressive design in NX begins with a 3D part model. You can import CAD models from other systems, create a part model in NX, or select an NX model. NX automatically recognizes sheet metal features in imported models.

NX automatically unfolds 3D part models based on straight break features to create a formable blank.

NX Progressive Die Wizard includes tools for nesting part blanks on sheet stock to minimize scrap.

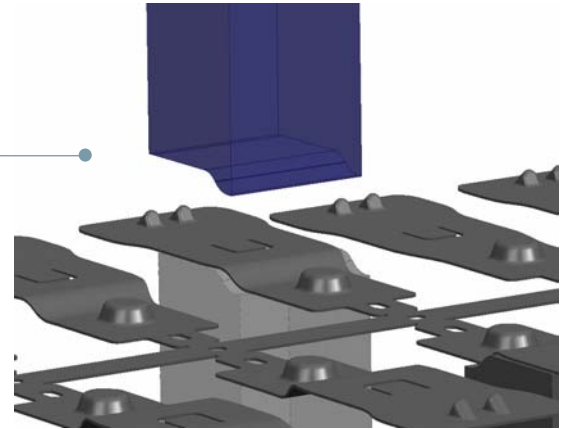
Die designers can quickly develop a skeleton strip with automated tools that rebend the blank models to simulate the forming operation at each die station. NX Progressive Die Wizard also calculates force center



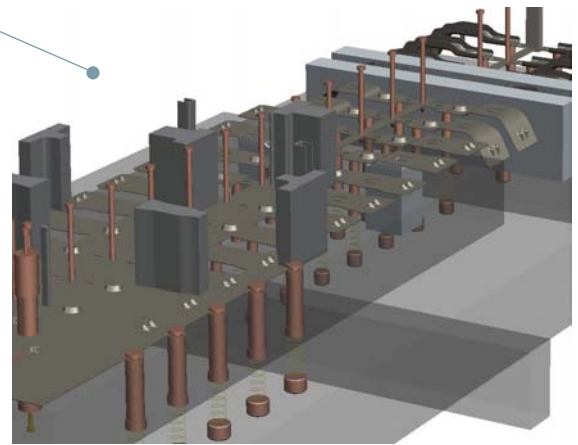
NX Progressive Die Wizard captures expert best practices and is highly customizable to your own preferred and proven methods

Phase 2: Die base design

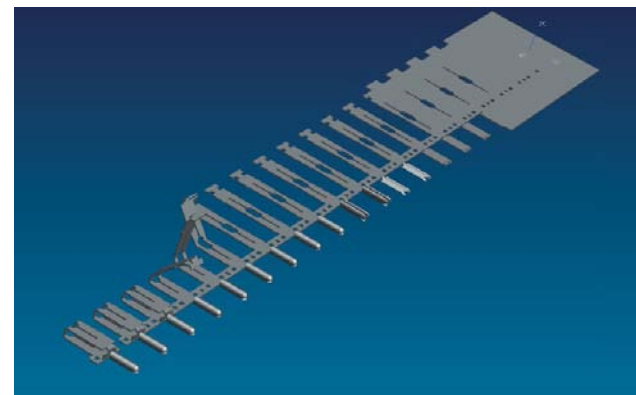
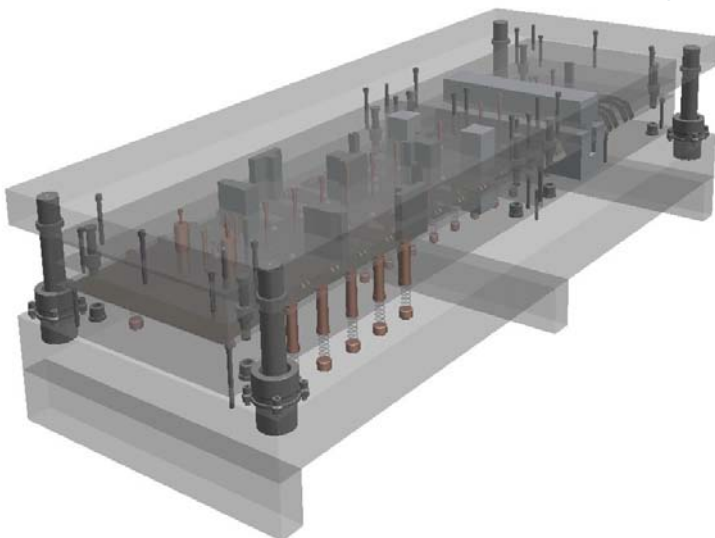
The die structure, stations and inserts are developed directly from the strip model, using preconfigured die bases, advanced die base design tools and more than 10 kinds of standard inset groups to accelerate the process.



NX provides a built-in standard part library that includes most suppliers' catalogs. Customizable die base libraries, standard part libraries and insert group libraries expedite the die structure design and ensure the entire process is handled effectively.



Once the model of the die is complete, it takes very little additional time to generate as many drawings as needed to help shop floor personnel understand what they are going to build. Highly accurate and detailed drawings are fully associative to the die design. NX Progressive Die Wizard also maintains associativity with the part design through the entire die design process, carefully controlling part design changes through all die components.



Proven results

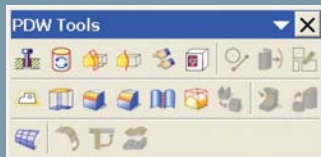
"Our purpose was to speed up die design without sacrificing quality. NX Progressive Die Wizard gave us that plus the ability to be innovative with our die designs and readily address today's more complex die requirements."

Marty Wiegel
President
Wiegel Tool Works

Progressive die design: key features

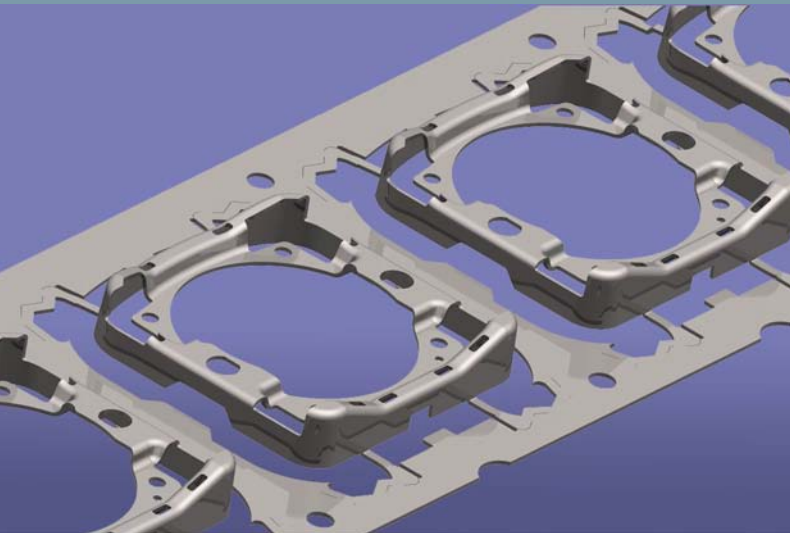
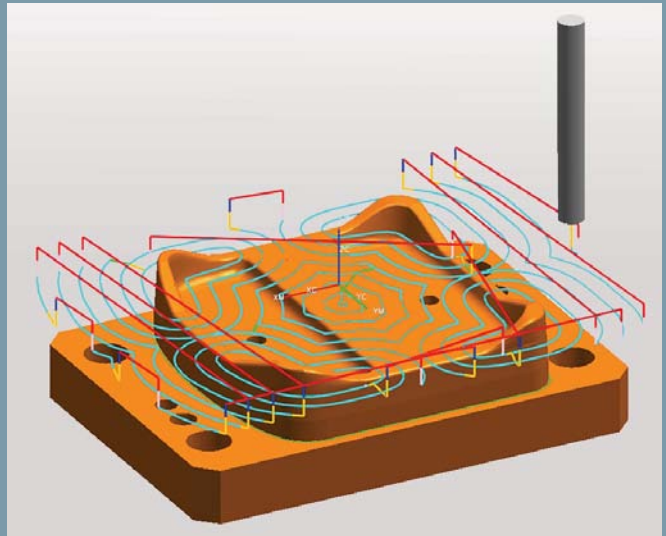
Key capabilities in NX Progressive Die Wizard

- Die design project initialization
- Automated sheet metal feature recognition
- Blank shape generator, includes formed shapes
- Blank layout
- Scrap design
- Strip layout and 3D operation simulation
- Force center calculation
- Die base design
- Die preference setting
- Punch/die insert design
- Standard part library
- Relief design
- Pocket creation
- BOM output
- Assembly drawing creation
- View manager



NX Machining for die insert and structure machining
NX offers robust milling programming with high-speed machining functions – ideal for fine finish on detailed dies in hard materials.

Easy-to-use planar and cavity milling as well as automated hole making are productive tools for NX programming on die structures.



Proven results

“To truly automate the design of progressive dies, you need two things: an intelligent wizard and highly advanced modeling technology. NX is the only software that has both elements. The competition doesn’t even come close.”

Michael Molina II
President

Progressive Design Technologies

Jig and fixture design

NX offers the most powerful capabilities in geometric and large assembly modeling, making it ideal for all types of fixture design.

Easy, fast updates

Full associativity between the product model and the fixture can ensure fast, accurate updates. When the fixture design is dynamically associated with the part or product model, the fixture model can be updated automatically if the design changes.

Simulation

Easy-to-use kinematic software can be employed to display and check mechanism motion. NX also offers a wide range of tools for stress analysis to help optimize structural performance.

Complex configurations

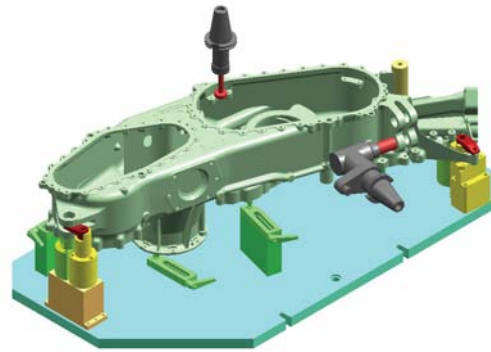
Using Teamcenter® software extensions to the NX Managed Development Environment, tool designers can define, store and re-use an unlimited number of alternative fixture configurations.

Automatic part positioning

The NX assembly mating conditions allow new or updated part of the same type to be positioned in the fixture automatically.

Multiple arrangements

NX can display multiple arrangements of fixtures that have different conditions, for example, opened or closed positions.

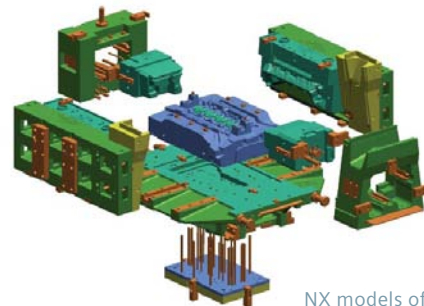


Fixturing designed in NX for a complex part ready for tool paths to be generated in NX Machining.

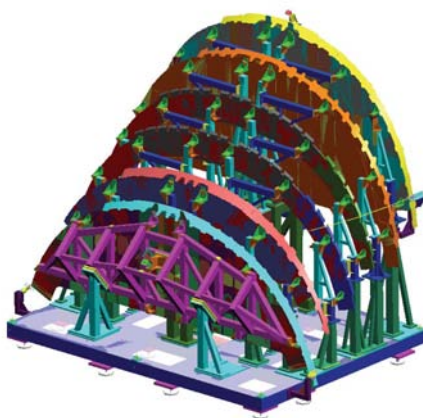


Image courtesy of J.S. McNamara Inc

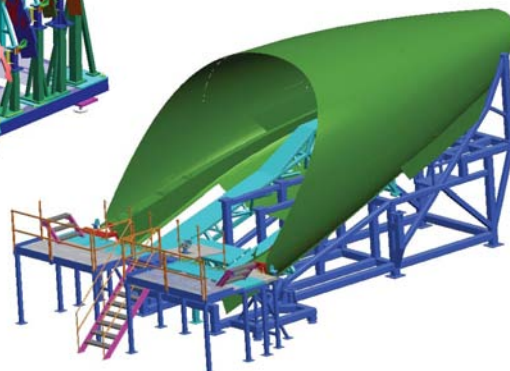
Welding fixture complete with clamps and welding guns for an automotive assembly.



NX models of sand casting molds and associated equipment for automotive engine components.



Large aerospace fixtures combine complex product shapes with large assemblies and human access considerations.

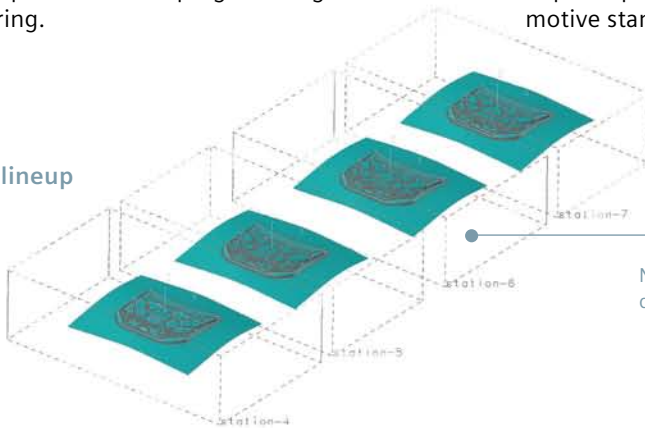


Automotive sheet metal stamping

Siemens delivers a comprehensive solution for automotive dies – from sheet metal design, through stamping process design and optimization, die face design, die structure design to a complete set of NC programming tools for die manufacturing.

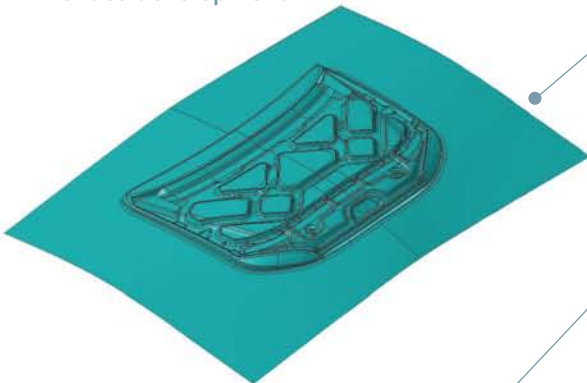
NX, in combination with Tecnomatix® software and Teamcenter applications, addresses the complete die design, engineering and manufacturing workflow to improve process efficiency and part quality for automotive stamping.

Die operation lineup



NX Die Engineering provides tools to determine the die operation across a complete press line.

Die face development



NX can produce a representation of the sheet metal for the draw, trim and flange elements of the die process.

Formability analysis

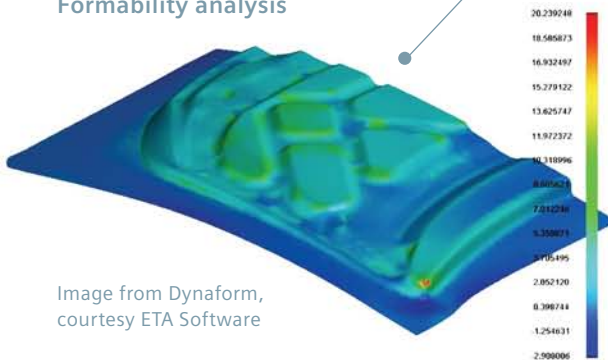
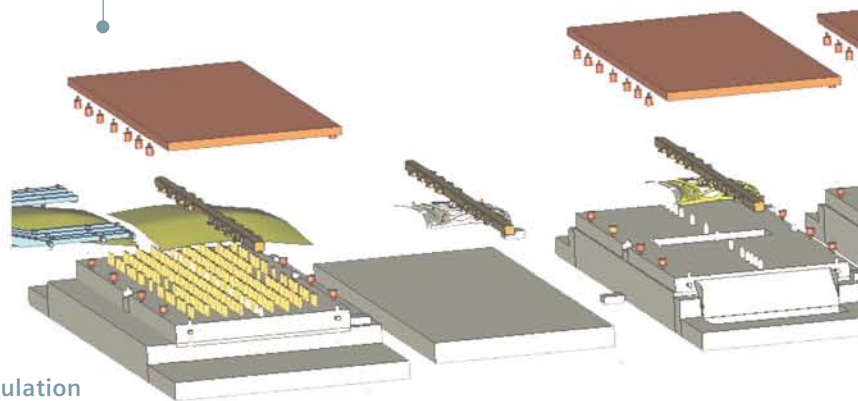


Image from Dynaform, courtesy ETA Software

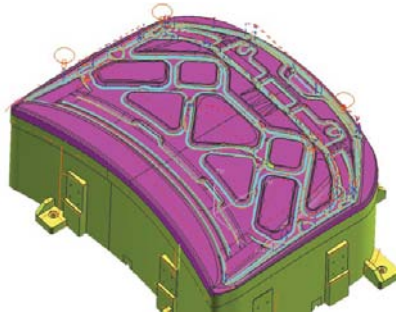
NX can interface to a number of analysis applications to check formability.

Tecnomatix Stamping application allows the designer to simulate the intended operation of the press line, individual press elements and inter-press handling equipment.

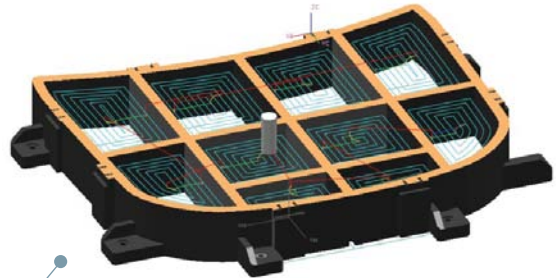
Initial press line simulation



> From design to manufacture – the complete process



Die machining

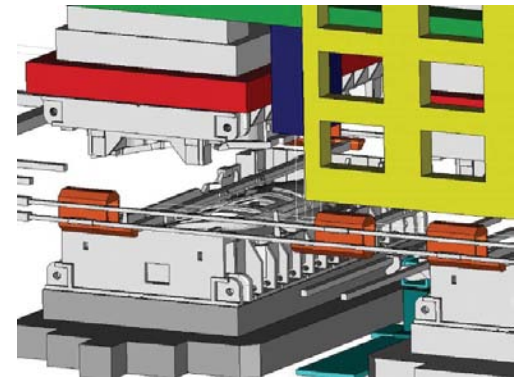


Casting pattern machining

NX Machining provides first-class capability in die face machining with the latest techniques in high-speed machining.

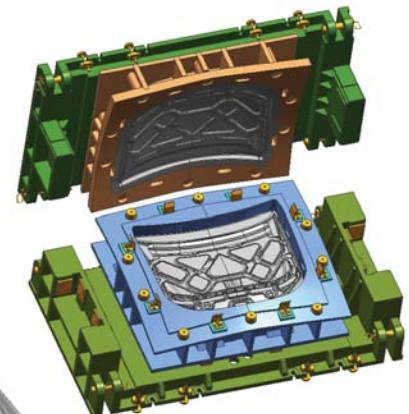
Highly productive milling applications in NX Machining enable fast NC programming for die structure components.

Detailed analysis and optimization by full press line simulation

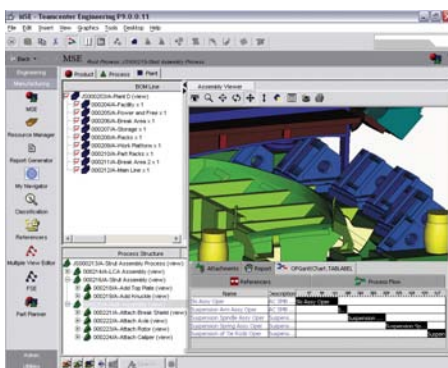


NX Die Design provides a range of capabilities for the detail design of the die structure.

Teamcenter Manufacturing provides powerful process planning, data management, configuration control as well as flexible reporting.



Completed die design

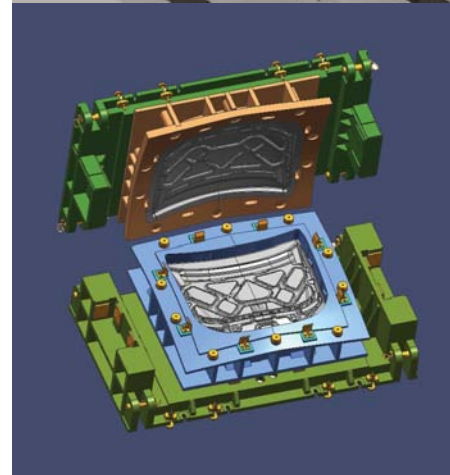
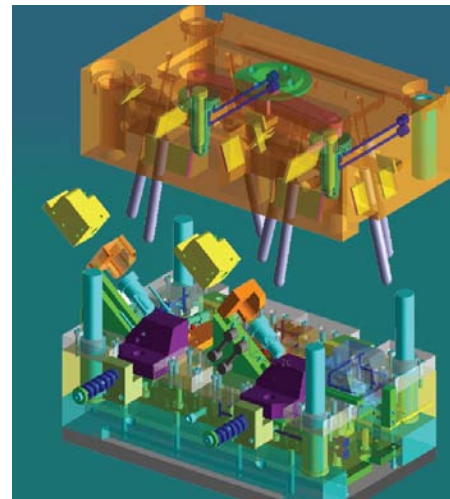
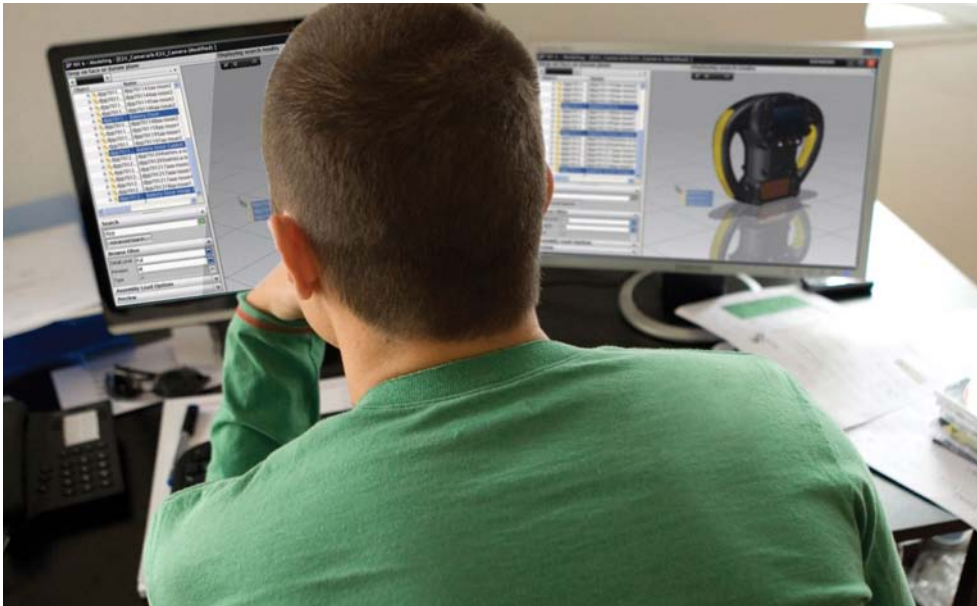


Process planning shop floor documents



Die structure design

Tool design within the NX Managed Development Environment



The NX Managed Development Environment provides tool designers with the ability to access the right data at the right time for the right job. Single parts to complete assemblies can be loaded into NX, shared in real time with other users and kept under full revision control. This saves time looking for data, reduces errors caused by using the wrong data and makes it easier and faster to share data.

The tool designer can access part designs, store tool and fixture designs in the NX Managed Development Environment. With comprehensive part and tooling data management, tool designers can quickly access part designs and store and re-use tool and fixture designs. A complete library of design and process knowledge promotes standardization through design re-use and reduces waste, errors and unnecessary rework.

Extensions to the managed development environment can offer comprehensive libraries for standard parts and subassemblies with powerful classification and search functions.

The NX Managed Development Environment is built on Teamcenter technology and is fully compatible with Teamcenter Engineering and Manufacturing.

The NX advantage

Throughout its broad product application suite, NX leverages key attributes that help companies achieve business objectives of waste reduction, quality improvement, shorter cycle times and greater product innovation. These unique attributes directly support business process initiatives aimed at transforming product development:

Managed development environment

NX solutions include fully integrated, synchronized management of all product data and process knowledge to transform product development with a structured collaborative environment.

Unified product development solution

Seamless integration of NX applications rapidly propagates changes of product and process information, replacing point solutions with a unified development system, from concept to manufacturing.

Knowledge-driven automation

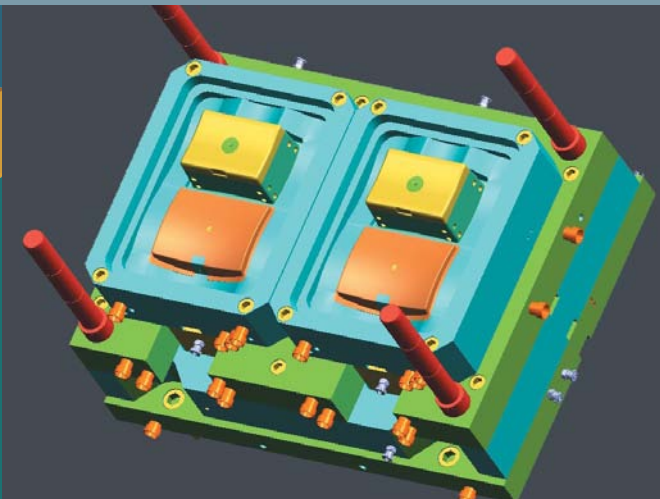
With NX, companies can apply product and process knowledge across all elements of product development to automate processes and maximize re-use.

Simulation, validation and optimization

Comprehensive simulation and validation tools in NX automatically check performance and manufacturability at every step of the development process for closed-loop, continuous, repeatable validation.

System-based modeling

NX structured conceptual models standardize design practices and allow rapid creation of variants, transforming development from component-based design to a systems engineering approach.



Siemens PLM Software

Headquarters

Granite Park One
5800 Granite Parkway
Suite 600
Plano, TX 75024
USA
972 987 3000
Fax 972 987 3398

Americas

Granite Park One
5800 Granite Parkway
Suite 600
Plano, TX 75024
USA
800 498 5351
Fax 972 987 3398

Europe

3 Knoll Road
Camberley
Surrey GU15 3SY
United Kingdom
44 (0) 1276 702000
Fax 44 (0) 1276 702130

Asia-Pacific

Suites 6804-8, 68/F
Central Plaza
18 Harbour Road
WanChai
Hong Kong
852 2230 3333
Fax 852 2230 3210

About Siemens PLM Software

Siemens PLM Software, a business unit of the Siemens Industry Automation Division, is a leading global provider of product lifecycle management (PLM) software and services with nearly 6.7 million licensed seats and 69,500 customers worldwide. Headquartered in Plano, Texas, Siemens PLM Software works collaboratively with companies to deliver open solutions that help them turn more ideas into successful products. For more information on Siemens PLM Software products and services, visit www.siemens.com/plm.

© 2011 Siemens Product Lifecycle Management Software Inc. All rights reserved. Siemens and the Siemens logo are registered trademarks of Siemens AG. D-Cubed, Femap, Geolus, GO PLM, I-deas, Insight, JT, NX, Parasolid, Solid Edge, Teamcenter, Tecnomatix and Velocity Series are trademarks or registered trademarks of Siemens Product Lifecycle Management Software Inc. or its subsidiaries in the United States and in other countries. All other logos, trademarks, registered trademarks or service marks used herein are the property of their respective holders.