

# The PLM Components Newsletter

## CONTENTS

Welcome to the second edition of *The PLM Components Newsletter*. PLM Components are software tools developed by UGS for product design, manufacture, engineering, simulation, visualization and collaboration that are made openly available to other application developers in the CAD/CAM/CAE/PLM industry. Readers that are new to PLM Components will find more information on [www.ugs.com/products/open](http://www.ugs.com/products/open).

### PLM Components drive profitability in new markets

New communities of software vendors are now driving revenue growth and keeping costs under control by accelerating their development of innovative solutions using UGS' PLM Components.

Applications for our software tools have moved beyond the mechanical field into areas such as architectural, civil and structural design. Many application developers whose main focus is not CAD, such as CAM, CAE, CMM, Reverse Engineering and Sales Configuration, are supplementing their core business with modeling components developed by UGS that are optimized to the needs of their users and seamlessly integrated with their core product line. Our flexible licensing arrangements and a simple integration process have enabled these organizations, large and small, to bring innovative capabilities to their applications quickly and economically. Many examples are given in this newsletter.

### Two new releases of Parasolid software make 3D modeling easier and more efficient

Since the previous newsletter there have been two major releases of Parasolid®, the world's leading modeling kernel.

Parasolid V17.1 (December 2005) included new tools for efficient 3D model construction, editing, refinement and for CAM applications. Also featured was support for advanced Microsoft technologies including Visual Studio 2005 and .NET.

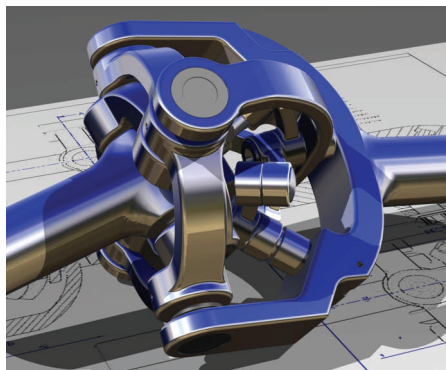

Parasolid V18.0 (May 2006) introduced enhanced levels of user control over 3D model construction, editing and interrogation, as well as numerous improvements in application support functions. More details about these releases are on page 2.

### Leading 3D JT file format to be published

In January 2006 UGS announced its intention to publish the widely adopted JT file format demonstrating its commitment to providing open software solutions for the benefit of Product Lifecycle Management application users. More on page 4.

*"All the big PLM vendors like to talk about how open they are; only UGS has been willing to make the hard decisions that give users control of their data."*

*- Evan Yares, Open Design Alliance*

PLM Components .....	1
Parasolid releases .....	1
JT to be published .....	1
Parasolid product news .....	2
CMM performance .....	3
CAM accuracy .....	3
Motion simulation .....	3
Parametric modeling .....	4
PLM Vis .....	4
New brochure .....	4
Contact details .....	4

### Business news

**Adobe Systems**, USA, joined the JT Open Program supporting the growth and proliferation of UGS' leading 3D JT data format.

**TDCI**, USA, licensed the D-Cubed 2D DCM for its BuyDesign sales configuration product line. The 2D DCM supports the rapid design and modification of highly configurable products, such as doors and windows.

**CD-adapco**, USA, a global provider of simulation software and services for fluid flow, heat transfer and stress, licensed the Parasolid Bodyshop, IGES and STEP interoperability components, further extending their long-standing relationship with UGS.

More business news on pages 2 and 3.

### Readers' Choice Award from Desktop Engineering



In the June 2006 issue of Desktop Engineering magazine, Parasolid was named winner of the latest Readers' Choice Award. The award was made after an article about Parasolid version 17.1 was published in the March 2006 issue of the magazine.

## Parasolid product news ...continued from page 1

Some of the new features in Parasolid 17.1 and Parasolid 18.0 are listed below. For further details, please visit [www.ugs.com/parasolid](http://www.ugs.com/parasolid).

- New manufacturing support functionality for solid tool-path simulation and hole identification, including perforated, open or trimmed blended holes.

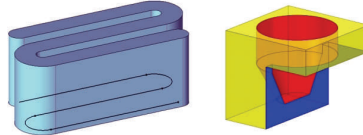

- Extended functionality for local editing with new patterning capabilities across multiple faces, and new face patching controls for fast local modifications.



- Finer user control of thickening, tapering and embossing operators, including retention of protruding features during tapering.

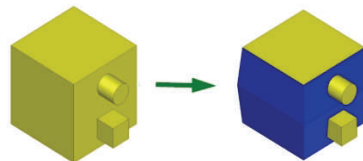

- Improvements in partition management, rollback efficiency and data tracking to boost application performance.

Further recent enhancements have been made in the following areas:

- Blending in tightly-curved regions
- Blend limiting and capping
- Blending in complex configurations
- Efficient sheet modeling and construction
- Local hidden line rendering and non-destructive sectioning

### Parasolid Interoperability Components news

In June 2006 UGS released Version 9.0 of Parasolid Bodyshop, a toolkit that repairs, optimizes and validates data imported into Parasolid in order to maximize the success of downstream modeling operations. This latest release features significant performance improvements in both data cleaning and error recovery, supplemented by enhanced post-processing of B-spline geometry and new platform support for 32-bit MAC OS X on PowerPC and Microsoft Visual Studio 2005 on Windows.

At the end of July 2006 UGS will be shipping a new release of the Parasolid Translator toolkits. UGS recently acquired rights to the source code for the IGES, STEP, Catia V4 & Pro/Engineer Translator toolkits from its 3rd party supplier, and with the new release we have added support for Microsoft Visual Studio 2005 for the above formats. Other changes to the Parasolid interoperability portfolio include the addition of a bidirectional Parasolid Translator toolkit for Catia V5, and discontinuance of the Parasolid Translator toolkit for VDA-FS.

### Parasolid and D-Cubed components: Microsoft environment support

Parasolid and D-Cubed components support the new technologies released in Microsoft Visual Studio 2005. In particular, the 64-bit Windows platform is now fully supported using the latest X64 compilers, enabling applications to utilize these components with very large data sets to achieve unparalleled performance and scalability. The components have also been built on 32-bit Windows, including an upgraded Pentium 4/SSE2 build for Parasolid (scheduled August 2006 for D-Cubed), using the compilers from Microsoft Visual Studio 2005 to deliver improved performance and reduced code size.

Parasolid also now ships with a .NET binding, allowing customers to integrate Parasolid into applications based on the latest Microsoft .NET technologies with a minimal performance overhead.

## Business news

**Numeca International**, Belgium, a provider of computational fluid dynamics (CFD) software and consulting services, licensed Parasolid Editor for use in their HEXPRESS and AutoGrid grid generation software.

**NC Graphics (Cambridge)**, UK, a developer of CAD/CAM software for the precision engineering industries, licensed Parasolid Communicator to provide enhanced interoperability for their DEPOCAM high-speed CAM system.

**HAAS Schleifmaschinen**, Germany, manufacturer of the Multigrind series of high-precision multi-axis grinding machines, licensed Parasolid Designer for use in their companion machine simulation software system.

**CoMeT Solutions**, USA, a developer of software used to enable simulation-driven engineering, licensed Parasolid Editor for use in its CoMeT product for multi-CAE solver assembly simulations, adding the ability to analyze Parasolid-based models.

**Thermwood Corporation**, USA, licensed the 2D DCM to increase the parametric functionality in eCabinet Systems, a CAD/CAM application for the wood working industry. As well as the software, eCabinet Systems is a cooperative that connects custom cabinet and furniture shops, industry vendors and furniture designers.

## Business news

**AVL List**, Austria, licensed the 2D DCM to enhance the modeling capabilities in their FIRE (computational fluid dynamics) and EXCITE (flexible Multi Body Systems) solutions for powertrain simulation.

**DataSolid**, Germany, licensed and released the 3D DCM to add assembly capabilities to its CADdy++ mechanical CAD product line.

**ABAQUS, Inc.** USA, released the 2D DCM in ABAQUS/CAE. The 2D DCM supports a constraint-based sketching environment, enhancing the parametric modeling capabilities in the pre-processor environment of the ABAQUS suite of finite element analysis (FEA) software.

**FAST AG**, Germany, licensed the 3D DCM for use in the GraphiteONE Linux based CAD system. The 3D DCM brings 3D parametric sketching capabilities to the GraphiteONE modeling environment.

**IronCAD**, USA, released the 3D DCM in IronCAD 8.0. The 3D DCM enables IronCAD users to assemble parts using a wide range of geometric constraints and to simulate the kinematic behavior of the assembled parts.

**CAD Systems**, Belgium, released the 3D DCM in Parabuild. The 3D DCM supports a novel application of geometric constraint based 3D modeling for steel construction.

**ATK Launch Systems**, USA, licensed the 2D DCM to enable the company to add new parametric design capabilities to FemBuilder, its proprietary CAE solution for the design and analysis of solid rocket motors.

## D-Cubed product news

### Boosting Coordinate Measuring Machine performance

Metris UK used the latest release of the D-Cubed Collision Detection Manager (CDM) to boost off-line simulation performance in its Camio Studio Coordinate Measuring Machine (CMM) application.

*"We can now determine potential collisions between measuring probes and work pieces more quickly than ever without any compromise on accuracy,"* said John Wootton, Director, Software Engineering, Metris UK.

The new CDM functionality enables applications to find the first collision, if any, along a linear path in a single step. A single computation removes the need to sample different positions along the path, dramatically improving simulation performance and reliability. The CDM is operating on accurate geometry, avoiding the inaccuracies of collision systems that are based on faceted models.

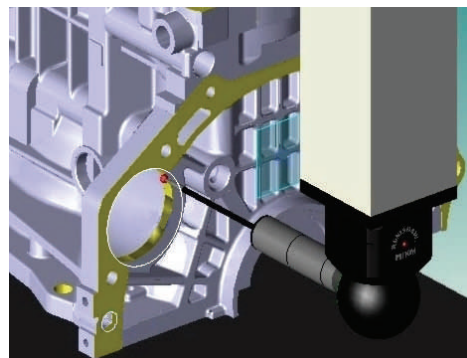

*Off-line simulation with high-speed collision detection*

### Accurate gouge-checking in Computer-Aided Manufacturing

The CDM has been released in NX CAM from UGS, enhancing gouge checking reliability in off-line machining simulation. This is made possible by the CDM's ability to operate on accurate solids with excellent performance. All toolpath collisions, no matter how small, are eliminated during the off-line simulation process, averting potentially expensive work-piece gouges prior to manufacture.

### Latest developments in advanced motion simulation

Assembly and mechanism motion simulation in version 19 of Solid Edge® software from UGS was enhanced with the latest releases of the D-Cubed 3D Dimensional Constraint Manager (3D DCM) and Assembly Engineering Manager (AEM). The AEM is used in Solid Edge to interactively simulate the behavior of parts that collide and transmit motion. Version 19 enables a much wider range of assemblies to be analyzed. In addition, motors can now be used to drive parts, expanding the range of models that can be simulated.

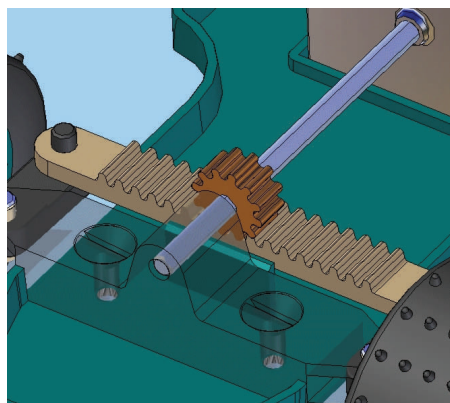

*3D DCM based rack and pinion*

Extending its use of the 3D DCM to solve assembly constraints, Solid Edge has also implemented 3D DCM equation solving, where variable dimension values such as distances or angles can be linked with equations. This enables end-users to model more sophisticated relationships, such as the rack and pinion illustrated opposite. Furthermore, these sophisticated relationships are now satisfied during an AEM-based simulation. More D-Cubed stories are on page 4. For additional information, please visit: [www.ugs.com/d-cubed](http://www.ugs.com/d-cubed).

**D-Cubed product news ...continued from page 3****New developments for parametric modeling****3D sketching**

Moving beyond the 3D DCM's use in constraint based assembly part positioning, recent developments have focused on optimising the 3D DCM for a broader range of applications, including 3D sketching. Improved 3D sketching functionality supports advanced solutions for curve-based surface, piping, wire harness and HVAC design. CAD applications that already use the 3D DCM in support of 3D sketching processes include HiCAD neXt from ISD, Solid Edge from UGS and SolidWorks from SolidWorks.

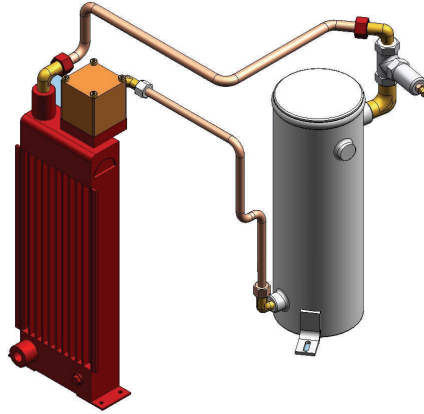

*3D DCM based pipe route sketching*

**More versatile 2D sketching environments**

Sketching environments based on the 2D Dimensional Constraint Manager (2D DCM) are evolving. CAD applications are strengthening their 2D design capabilities, in some cases reducing the necessity of converting the 2D sketch to a 3D model, improving productivity. To support these developments, the 2D DCM's ability to model layouts has recently been improved. Dimensioning is more flexible, with the ability to apply an excess of consistent dimensions without invalidating the sketch. Also improvements to solving constraints on rigid 2D parts mean that they can be positioned with greater flexibility.

The D-Cubed Profile Geometry Manager (PGM) extends the capabilities of current sketching systems, providing high-level tools for offsetting and constraining loops of geometry. Productivity is improved by automatically inserting, extending and trimming edges during the offsetting process. Recent developments include greater flexibility when editing profiles and better support for subsequent history-based modeling operations. Current developments focus on loop length and area constraints.

**PLM Vis: customized visualization applications**

PLM Vis provides 2D/3D visualization and markup tools that are easily integrated into PLM applications. It is used by Independent Software Vendors to enhance their applications and also by End-Users to enrich proven or develop new business practices through the power of custom visualization. PLM Vis supports UNIX as well as the PC and can be embedded in standalone applications or as internet browser plug-ins. Recent growth in the user base has seen Suzuki, The Boeing Company, LGE, and Emerson-Copeland deploying customized PLM Vis based 2D and 3D viewing applications without having to introduce any new file formats. PLM Vis enables organisations to develop user interfaces focussed on their specific requirements, the results being easy to use and free from the distractions of more general purpose applications. For further details visit [www.ugs.com/plmvis](http://www.ugs.com/plmvis).

***"The UGS PLM Vis toolkit helped us save time by not having to reinvent the wheel for view-markup technology. We were able to better utilize resources and produce a better product utilizing PLM Vis technology."***

***- Rob McNiff, VP Development, Visiprise***

**Publishing JT ...from p1**

JT is the dominant lightweight 3D data format for product visualization, collaboration and application interoperability in the global manufacturing industry.

Publication of the JT format will enable easy access for the software suppliers and end-users that rely on this technology.

"This further validates UGS' commitment to provide open software solutions for the global manufacturing industry," said Chuck Grindstaff, executive VP of Products, UGS.

For more information about JT, please visit [www.jtopen.com](http://www.jtopen.com).

**New PLM brochure**

The new PLM Components Overview brochure is now available. Please use the contact details below to request your copy, or download from:

[www.ugs.com/products/open/library](http://www.ugs.com/products/open/library)

**Contact details**

Contact details for each technology covered in the newsletter can be found on the website listed in the relevant section.

Alternatively, please use the contact details below and your enquiry will be forwarded to the appropriate recipient:

D-Cubed,  
Park House, Castle Park,  
Cambridge, CB3 0DU,  
England.

Tel: +44-1223-722600

Fax: +44-1223-722601

Email: [d-cubed.sales@ugs.com](mailto:d-cubed.sales@ugs.com)

Web: [www.ugs.com/products/open/](http://www.ugs.com/products/open/)

© UGS 2006. All rights reserved. UGS, Transforming the process of innovation, Solid Edge and Parasolid are registered marks or trademarks of UGS Corp. or its subsidiaries in the United States and other countries.

All brand and product names mentioned in this newsletter are the service marks, trademarks, or registered trademarks of their respective owners.