

Solid Edge Sheet Metal

White Paper

An intelligent process-specific sheet metal environment is available through Siemens PLM Software's Solid Edge® suite. Solid Edge Sheet Metal is the industry's most advanced sheet metal solution. This white paper describes how you can leverage Solid Edge with synchronous technology and Solid Edge Sheet Metal to speed design time and streamline manufacturing.

Contents

Executive summary	3
Meeting the challenge of sheet metal design	4
Challenges of sheet metal design	4
A new approach in sheet metal design	5
A complete and automated 3D sheet metal solution	6
Developing 3D sheet metal models with few or no commands	6
Improved methods for making design changes	7
Re-using supplier and legacy 3D designs	8
Usability balanced for experienced 2D and 3D users	8
Advanced sheet metal features	9
Built-in design validation.....	10
Documentation and manufacturing support	11
Flat pattern development.....	12
Conclusion	14
Further reading	15
Glossary	16
References	18

Executive summary

If your company designs sheet metal parts, it faces a series of unique challenges. Although parts are typically designed in their “formed” state, they begin as a flat plate. As a result, manufacturability becomes a critical aspect of every feature making up the finished part. Add to this the need to account for material thickness, along with bend and corner relief, miter deformation features and critical dimensions (inside or outside). When you take all of this into consideration, it becomes obvious that you need a highly specialized set of tools if real productivity and quality gains are to be realized from design through manufacturing.

This white paper discusses how careful consideration of the sheet metal process, as well as extensive research into the use of sheet metal components, led Siemens PLM Software to develop Solid Edge Sheet Metal, the industry’s most advanced set of sheet metal modeling capabilities.

The Solid Edge sheet metal environment is a core design capability that includes an entire design-through-fabrication workflow and streamlined modeling commands tailored to the unique needs of sheet metal design. As result, Solid Edge Sheet Metal helps ensure that designed parts can be manufactured, documented and utilized by CNC machinery.

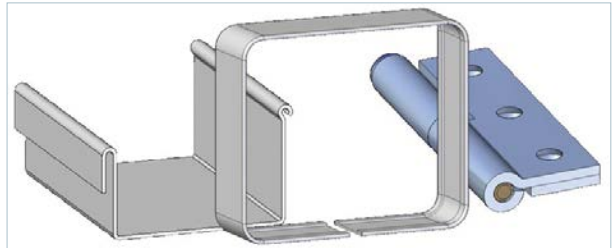

Meeting the challenge of sheet metal design

Challenges of sheet metal design

Before we take a close look at how Solid Edge approaches sheet metal design, let's first understand what engineers struggle with when choosing a 3D system for sheet metal design.

- Most traditional 3D CAD systems are history-based systems that require special commands and workflows to create even simple parts. Typically, users need specialized training, which can result in downtime during adoption.
- While designing sheet metal parts in traditional 3D CAD is faster than 2D, these history-based systems force users to preplan designs to accommodate future changes. Unless models are carefully constructed, some edits can't be made without starting from scratch.
- Engineers migrating from 2D may not be aware that a process change is required when moving to a traditional 3D CAD system. Since in-house edits can't be made to imported data, supplier change fees can result.
- Some productive modeling methods in 2D simply can't be duplicated in traditional 3D. This forces new users to learn steps that are less efficient.
- The sheet metal command sets of many CAD programs lack depth, leveraging generic design tools for sheet metal design. This requires you to use workflows, commands and features more appropriate for machined, cast or molded parts.
- Designers don't have access to design validation tools while designing sheet metal components. This can lead to unmanufacturable parts or parts that break design rules (sensors and analysis).
- With respect to documentation and manufacturing support, current working drawings don't reflect the entire sheet metal process, such as bend tables and flat patterns. Also since the shop floor cannot take advantage of manufacturing data present in 3D designs, this can lead to a disjointed process, often requiring the use of separate applications.

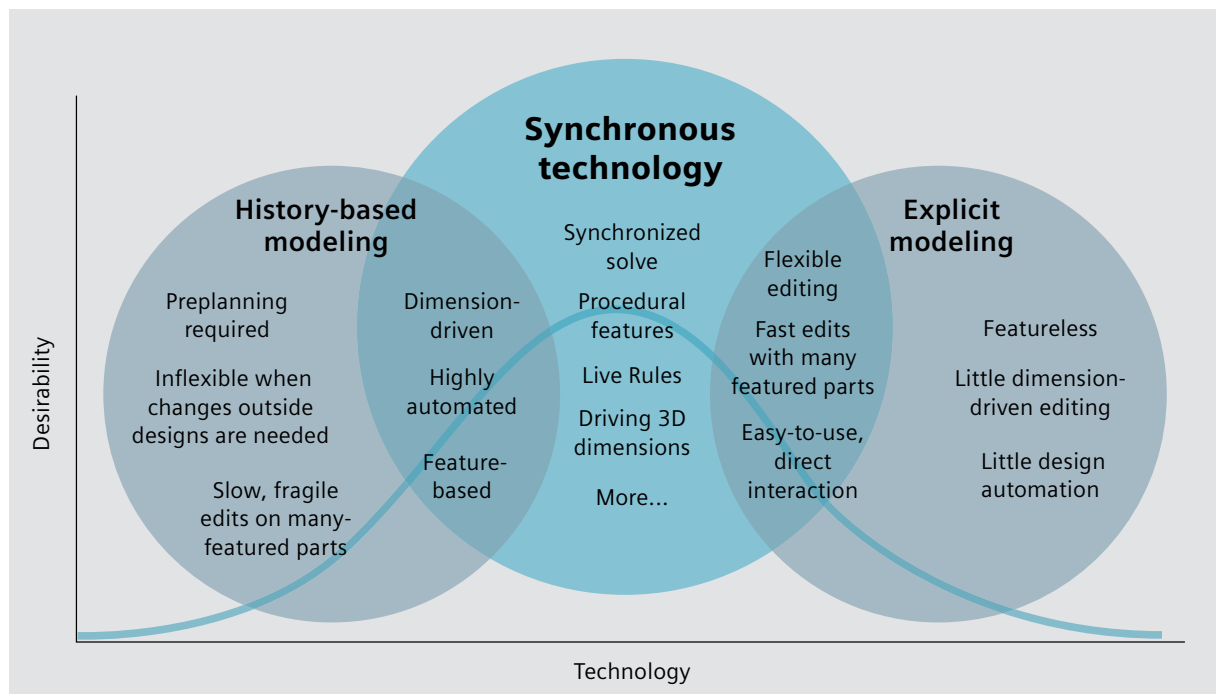

Figure 1: Defining synchronous technology.¹

A new approach in sheet metal design

Solid Edge with synchronous technology enables you to resolve these key issues. It might be best to start by describing how synchronous technology differs from other mainstream modeling technologies and explain why Solid Edge is more efficient.

Before Solid Edge with synchronous technology, there were primarily two mainstream 3D modeling technologies – history-based or traditional modelers and explicit modeling systems. History-based modelers use a feature-based approach to create and edit a model. In addition, since they generally are dimension driven, their automated model changes are reliable and predictable. However, achieving any predictability requires a lot of preplanning. Unforeseen changes usually require failed features to be fixed or parts to be remodeled.

Alternatively, there are history free modeling systems, which are sometimes called explicit modeling systems. These featureless systems offer little in terms of automated design capabilities with dimensions or relationships. But, they are fast and flexible and can accommodate a wide variety of changes, assuming that their proprietary geometry kernels can handle such modifications.

Solid Edge with synchronous technology incorporates the best of both worlds by combining the speed and flexibility of explicit modeling and the precise control of parameterized design. This technology is found in the Solid Edge suite's part and assembly solution. Solid Edge with synchronous technology is ideally suited to sheet metal design. At this point, the white paper will take a closer look at the main features that Solid Edge with synchronous technology provides to solve the typical sheet metal problems outlined earlier.

A complete and automated 3D sheet metal solution

Developing 3D sheet metal models with few or no commands

Direct interaction paradigm To speed the development process, users can drag 2D sketches directly into a 3D model using grab and go tools. Special handles (available through the system's steering wheel) are displayed on geometry such as faces or regions. These handles let users drag these elements into new features, as well as enable them to modify existing parts. Regions are automatically created from imported drawings, which speeds model development. Users can draw sketches in space or on a face for immediate use to add or remove sheet metal material. The steering wheel is designed to work with sheet metal parts – so thickness faces can get extended, bend radii can get changed and flanges can get pushed in, out or rotated even if corner treatments are applied. These capabilities are especially valuable since it's been proven that fewer commands result in fewer steps – and fewer steps are directly related to a faster design process.

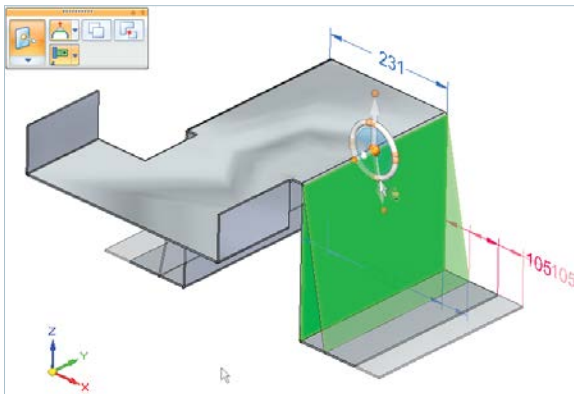

Figure 2: Grab and go design.²

History-free, feature-based modeling The heart of fast sheet metal modeling is facilitated by the Solid Edge ability to store features in a collection – instead of in a linear feature tree that traditional CAD systems use. Linear feature trees force a specific edit order and require model regeneration during any change. With synchronous technology, features are no longer dependent on each other. This enables you to organize and edit your features as fast as you move your mouse. The ability to collect features allows reordering, grouping and sorting by name or type. You can easily group holes, rounds or cutouts together regardless of when they

were created. You can even reorder holes to the top of the collection. Features can be selected, edited or deleted with no performance penalty from model regeneration.

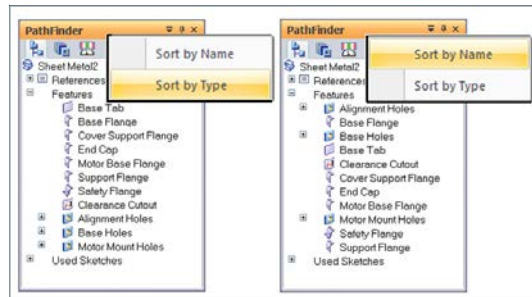

Figure 3: Feature collections in synchronous technology.³

Sheet metal-based procedural features Some specialized sheet metal capabilities let you create features using sketches and engineering parameters and make edits by adjusting those same input parameters. However, unlike history-based systems, unrelated geometry and even downstream operations are not regenerated. Features such as tabs and flanges are best edited using the resulting geometry. However other features, such as holes, dimples and louvers, are best edited using the original parameters. This enables you to establish, maintain and edit design intent without expensive model regeneration.

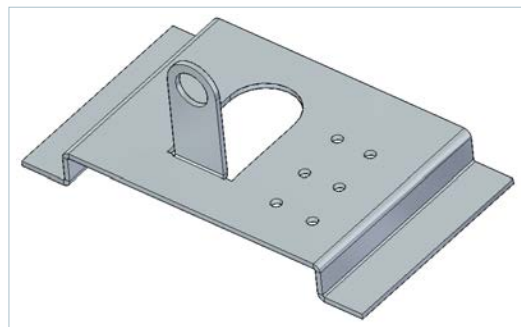

Figure 4: Specialized sheet metal features.⁴

Improved methods for making design changes

Live Rules Synchronous technology provides a powerful capability called Live Rules, which enables engineers to get predictable changes with or without constraints. Specifically tuned for sheet metal design, Live Rules automatically find and maintain geometric conditions during a drag or dimensional edit. Critical model parameters, such as thickness, bends and relief, are maintained during an edit. Other conditions – such as concentric, tangent, symmetric, horizontal, vertical and even co-planar conditions – are kept during edits. Intelligent models can be developed even if no relationships are used during the creation process. Live Rules eliminate the need to apply complicated geometric relations while establishing design intent.

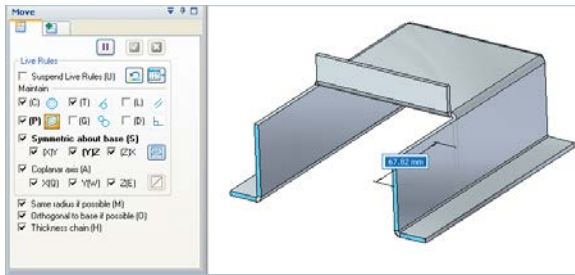

Figure 5: Live Rules.⁵

3D Driving Dimensions Unlike traditional CAD systems where dimensions can only drive their sketch elements, Solid Edge 3D Driving Dimensions can be added to any part of a 3D model, allowing you to drive critical inside or outside dimensions to establish rules as and when they are known. 3D Driving Dimensions allow edits and can be locked to preserve critical distances. They also can be used in formulas with other dimension or linked to spreadsheets to take advantage of engineering calculations.

With direction control, a value change can move either of the dimensioned elements, giving you the ability to control the position of geometry that was created earlier in the process. 3D model constraints can also be used to modify geometry making elements perpendicular, tangent or parallel; that relationship can be saved to retain these rules. Again because features and geometry are no longer dependent on each other, users can change either element and the other will react accordingly regardless of creation order. These capabilities enable engineers to make unplanned changes and establish rules when they are known.

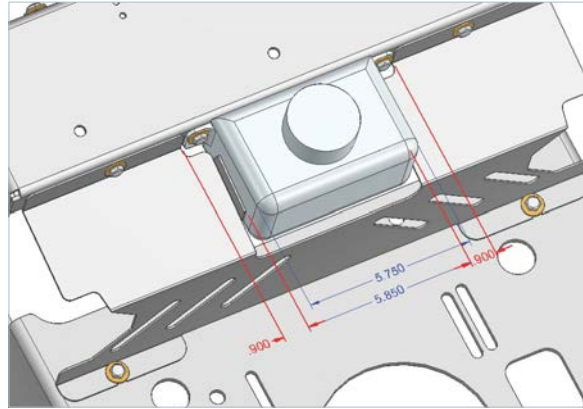

Figure 6: 3D Driving Dimensions.⁶

Nearly instant edit performance Synchronous technology's most significant difference is manifested by its independent features. Historically, traditional CAD systems force changes in one direction – down the tree in the order of creation, which regenerates all unrelated features. Obviously, this restricts a user's ability to make modifications since some features may need to be controlled by different operations. A classic example is where a flange needs to be moved while the distance to previously created flange has to be preserved. History-based systems force change to the parent feature, which eventually updates the location of the flange. With synchronous technology, engineers can edit the latter flange and drive the location of the previously created flange. Unrelated geometry is not regenerated, which facilitates faster model performance. By adopting an independent feature design, users can edit the first operation as fast as the last.

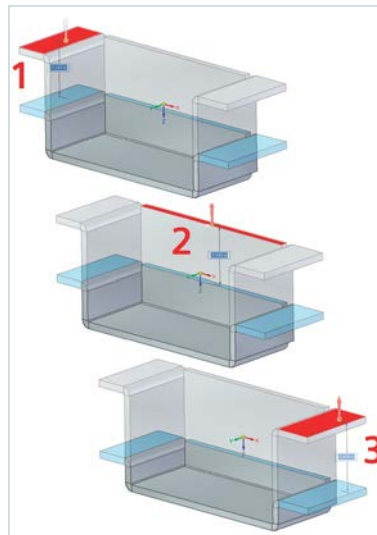

Figure 7: Independent feature design.⁷

Re-using supplier and legacy 3D designs

Edit supplier or legacy sheet metal designs Traditional CAD systems have always fallen short when it comes to editing supplier data. Most systems can open parts and assemblies and use them in designs – but the data can't be changed easily (or often times, not the way you require). Solid Edge with synchronous technology has the unique ability to take imported sheet metal model files and convert them to usable parts where edits can then be made. Key parameters, such as thickness, will be recognized as well as bends. Users can convert cutouts on flat faces or across bends to a procedural feature, allowing edits to the feature's sketch. Being able to edit imported data helps reduce supplier change fees as edits to outsourced data can be made in-house.

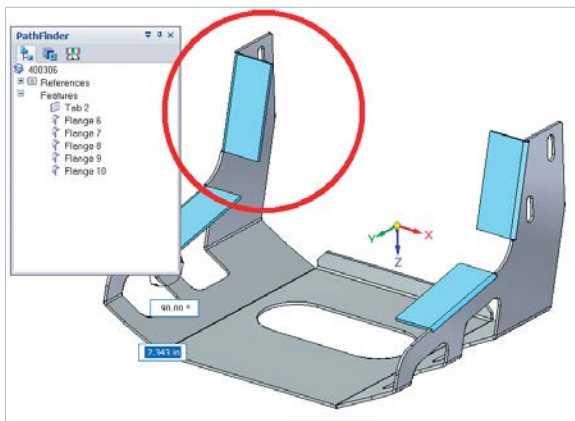

Figure 8: Editing imported data.⁸

Edit any model as if it was native geometry In order to work effectively with imported data, as well on foreign parts, all operations must be able to work equally. Solid Edge with synchronous technology, lets you continue design and make edits as if the parts were native geometry. You can drag sheet metal tabs or flanges with powerful grab and go handles and get predictable results from Live Rules. Live Rules find and maintain geometric relationships even on imported models. Precise control with 3D Driving Dimensions can be added to completed models and these dimensions can be saved with the model. You no longer need to remodel parts just to edit supplier data. You can eliminate change fees and lengthy turnaround times.

Migrate 2D to 3D Many companies moving to 3D already have a wealth of 2D drawings. Solid Edge is able to maintain these drawings while also enabling you to utilize them as you make your transition to 3D. The Create 3D feature allows you to choose 2D drawing views and have them automatically orientated in 3D so you can quickly start modeling. As 3D geometry is created, 2D dimensions are retained during the transition as editable 3D Driving Dimensions. Whether you migrate from AutoCAD, ME10 or even DXF, certain 2D dimensions automatically become editable 3D Driving Dimensions. Those dimensions can be locked to preserve values, linked to other dimensions through equations and even controlled through a spreadsheet. Solid Edge preserves your 2D drawing investments, while enabling you to realize immediate value from the move to 3D.

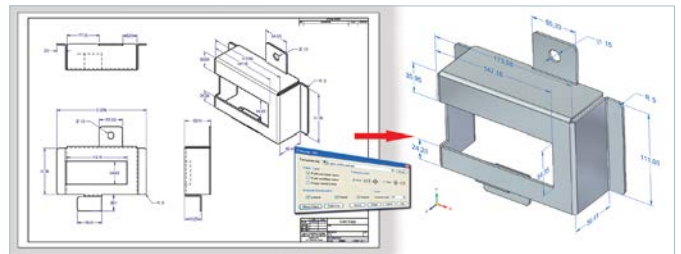

Figure 9: Migrating 2D dimensions to 3D.⁹

Usability balanced for experienced 2D and 3D users

3D fence stretching Moving flanges, cutouts or entire regions of a model is as easy as doing a stretch in 2D. Simply snap to a desired view – such as top, front – draw a fence around part of a 3D model and drag it into a shape. You cannot effectively edit in a history-based system because only single features can be edited at one time. During a 3D stretch in Solid Edge, key geometric conditions are maintained with Live Rules. 3D Driving Dimensions are used to control fit and position so that inside and outside conditions will be maintained. The process is as easy as 1-2-3. You can open a part or assembly, draw a fence and drag it into a shape. This editing process significantly reduces training costs and decreases downtime while moving to 3D.

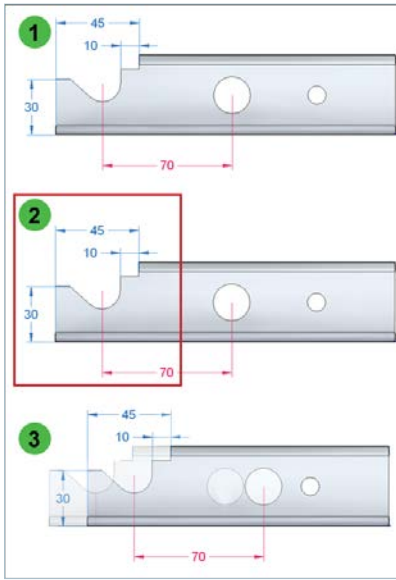

Figure 10: Leveraging familiar 2D editing techniques.¹⁰

Live Sections for 2D section editing Live Sections have also been applied to sheet metal. You can simply cut a section view through any part of the model and edit the resulting 2D cross section directly. You can add Live Sections from virtually any view and change parts fast. Live Rules maintain critical conditions (such as horizontal and vertical flanges) co-planar faces and material conditions (such as thickness and bends). Dimensions can be added to the 2D elements of a Live Section and locked to preserve critical distances of its 3D counterpart. The process is as easy as 1-2-3. You can open a part or assembly, draw a fence and drag it into a shape. This unique capability enables you to better visualize and address interferences between parts as easily in 3D as you did in 2D.

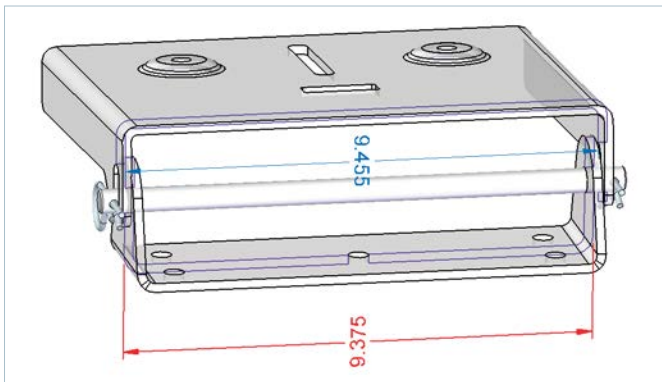

Figure 11: Live Sections.¹¹

Advanced sheet metal features

The command sets of many CAD systems lack depth They only provide generic design tools for sheet metal design, forcing you to use workflows, commands and features that are more appropriate for machined, cast or molded parts. Solid Edge specialized sheet metal design capabilities deliver significant productivity gains compared to general-purpose CAD tools. Solid Edge process-specific commands and structured workflows speed your ability to model sheet metal parts. Built-in intelligence saves additional time by automatically calculating material treatments and validating parts for manufacturability. In addition, manufacturing-ready flat patterns help to eliminate scrap and rework. The result is faster time to manufacturing, backed by improved quality of your sheet metal components.

Intelligent sheet metal features Solid Edge Sheet Metal addresses the unique challenges of working with sheet metal parts. When cutouts or holes lie across a bend, a traditional cutout command would result in nonperpendicular faces. In contrast, the Solid Edge normal cutout command helps you create accurate perpendicular faces, reflecting the fact that the feature would likely be manufactured while flat, and then folded.

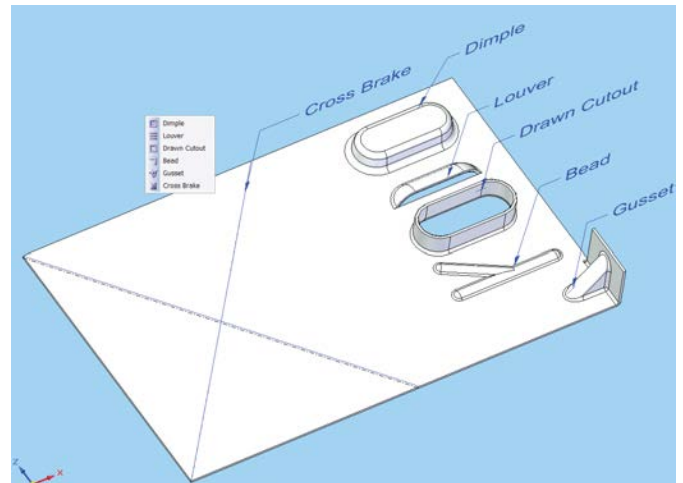

Figure 12: Deformation features.¹²

Deformation features, such as louvers and beads, are constructed by using a single, linear element and simply defining height and depth and deciding whether you want the louver ends formed or lanced. With these associative feature parameters, you can easily make style changes, such as changing a lanced-end louver to a formed-end louver. A more generic CAD approach – such as using library features – would often force you to start over.

Defining part properties The part properties tab on the options dialog box enables you to set up the sheet metal properties for the part you are constructing. These properties are copied to the variable table and used each time you create a new feature. For example, when you construct a flange, the material thickness and bend radius are automatically applied.

If you edit these values later, the part will update. For example, if the material thickness for the part needs to be increased, you can edit the value for the material thickness and the material thickness for the entire part will change.



Figure 13: Material property definition.¹³

Built-in design validation

Ensuring manufacturability Model validation is another area where Solid Edge is unmatched. A classic manufacturing issue involves cut-outs or flanges placed too close in proximity to other cutouts or bends. Typically, there is a minimum distance between bends that must be maintained to accommodate the bend die. Designers are aware of this but often don't measure each bend for validation. Solid Edge includes design sensors that handle this operation automatically. Other sensors can be used to help calculate cost, variables, surface area and other factors. A custom sensor capability is available if you need more options.

Solid Edge enables you to flatten and rebend sheet metal models, automatically calculating bends from standard or custom formulas. In addition to effortlessly creating an accurate pattern for manufacturing, this simplifies the modeling of cutouts and holes that lie across bends.

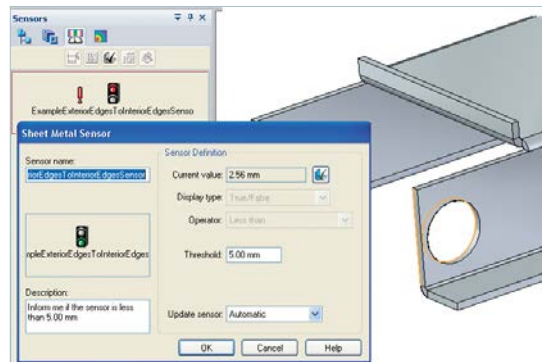

Figure 14: Sheet metal sensors.¹⁴

Simulation Solid Edge provides scalable finite element capabilities that can be seamlessly upgraded as your requirements grow. These capabilities include Simulation Express (included with Solid Edge Classic and Solid Edge Premium) and Solid Edge Simulation (included with Solid Edge Premium or available separately as an add-on for Solid Edge Classic), which are aimed at design engineers and fully embedded within Solid Edge. Full Femap™ software, a stand-alone product that offers advanced capabilities for analyst engineers, also is available. By using simulation at the design stage, designers can turn escalating customer demands into highly demanded products.

Simulation enables designers to reduce the need for physical prototypes, which brings significant time and cost savings. Savings can also be gained by using simulation to increase product quality, which reduces product failure and costly recalls. Design optimization ensures that designs are as efficient as possible by minimizing material and weight, while overall simulation promotes design innovation by producing objective results.

Solid Edge simulation includes several capabilities that are relevant to sheet metal design. Using a normal 3D finite element mesh approach to analyze extremely thin components in relation to their length (such as sheet metal components) is extremely resource intensive; it also yields inaccurate results. In contrast, Solid Edge uses 2D "plate elements" to analyze an automatically extracted sheet metal mid-surface, which delivers fast and accurate results.

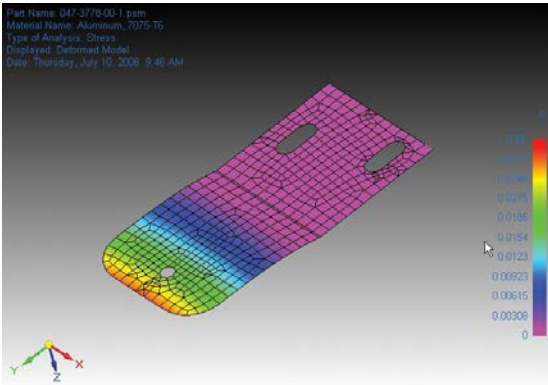

Figure 15: Simulation capabilities.¹⁵

Components that operate at high speed can start resonating at particular speeds (RPM) or frequencies (Hz), which can lead to catastrophic failure. This is hard to predict and often unrecognized until the machine is operational, resulting in costly consequences. The ability to predict the four major natural (modal) frequencies of a given component makes Solid Edge a practical solution for engineers who want to solve real problems early on at the design stage.

In addition, a Stress Wizard is available to take advantage of the Solid Edge “simplified parts” concept, which ignores design details that are not important to the analysis. Use of the wizard enables users to obtain accurate results in less time.

Documentation and manufacturing support

Highly productive 2D drafting Solid Edge streamlines drawing creation with the industry’s most productive drafting system. Formed and flattened components can be detailed, dimensioned and associatively retained so they automatically update when your designs change. Innovative tools for shaded views, exploded assemblies and detail and section views are quickly created to extend accurate design data into other areas of your business. Using Microsoft-standard OLE technology (object link and embedding), whole drawings or individual drawing views can be easily re-used in other document types, such as Word, Excel and PowerPoint (or any other document that supports OLE), to illustrate manuals, technical specifications, brochures and other kind of publications.

The paperless office has been promised for some time. Although this is technically possible with today’s Solid Edge design and collaboration tools, 2D drawings are still widely used by many companies that design their own products and want to relay manufacturing details to the shop floor or third-party manufacturing shops. While 2D has served many users well over the years and continues to allow you to create or maintain existing 2D drawings, the fastest way to 2D is to start with a 3D model. As you work in 3D, you only

create design details once. When your design is ready, you can create 2D orthogonal projections, isometric projections, detail and auxiliary views and other perspectives at will. These associative drawing views automatically update to reflect any design modifications to the 3D model, while the Solid Edge Dimension Tracker notifies you when dimensions, annotations or model-derived table entries have changed.

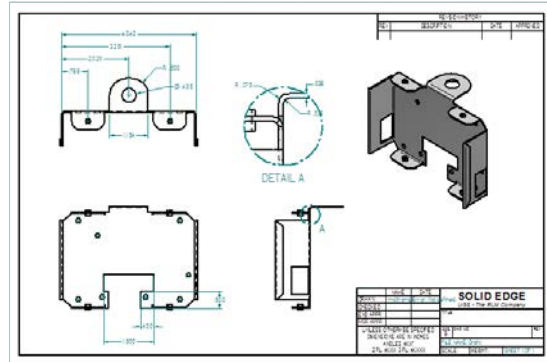

Figure 16: Solid Edge drawing capabilities.¹⁶

If more detail is required, additional views can be subsequently placed by “peeling” brand new orthogonal and isometric views from others already present. You can also use Solid Edge to create accurate section and high scale detailed views that include machining symbols, GD&T, bill of materials and auto ballooning. All of this can be created to comply with internationally recognized standards, including ISO, ANSI, DIN, JS, Russian and other established conventions, allowing you to establish fully production-ready drawings in Solid Edge.

Working in 3D enables you to realize additional downstream benefits as models move past the design stage. For example, hole tables and coordinate dimensioning ensure that you represent your parts in the best possible way for customers and manufacturing.

Manufacturing support Solid Edge Sheet Metal excels at providing highly flexible manufacturing support. There is a thin line between sheet metal design and manufacturing responsibilities, more so than in most design disciplines. The size of your company often determines where the designer leaves off and the production engineer takes over – as well as whether manufacturing fabrication takes place in house or is subcontracted out. Many times, the design engineer has to decide how specific components need to be made. Siemens PLM Software recognizes that this scenario will vary from company to company. Solid Edge Sheet Metal maximizes flexibility by enabling you to use the same data to complete manufacturing support at either the design stage or the manufacturing stage.

Flat pattern development

Solid Edge standard formula for calculating accurate flat patterns The neutral factor (or K factor as it is sometimes known) can be changed to suit specific materials, for example, 0.5 for mild steel, 0.33 for aluminum and 0.6 for stainless steel. The formula used in Solid Edge is standard throughout the sheet metal industry. Solid Edge uses the neutral factor, bend radius and bend angle to calculate the plastic zone length (PZL).

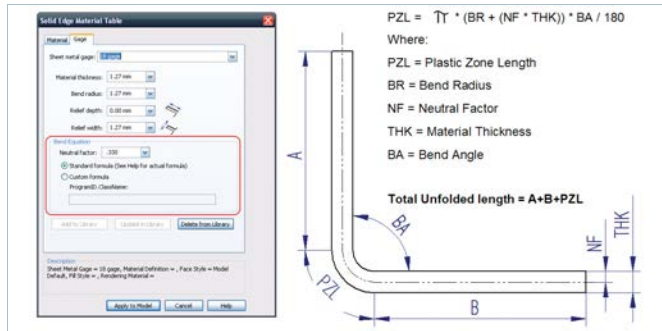

Figure 17: Flat pattern development.¹⁷

Folding sheet metal can be as much of an art as it is a science. In theory, all of the above is true and in 99 cases out of 100, the standard formula produces excellent results. However other factors outside of the design software can influence the bend characteristics during manufacturing. On single bends, this is not as apparent. However, a part with many bends can reflect incremental errors, where at least one of the dimensions can be way out of tolerance.

Custom formula Many sheet metal engineers who bend components have bend tables they have developed over time through trial and error. Solid Edge can use these tables to override the standard formula with sample test data from manufacturing. Solid Edge provides four examples under its “custom” directory. If the standard default formula does not yield the results you require, you can set up a manual override by defining your own custom formula and specifying that it be used to calculate the flat pattern size. You can use the three methods below to establish formulas for working with flat pattern data.

1. Designers can develop an accurate and associative flat pattern for 3D part files and save it in a separate data stream without having to manage a separate file. The flat pattern reports the maximum blank size for unfolded components, which can be linked to a sensor that will issue a warning if the raw material sheet size is too small. Product markup information (PMI) also can be added to the flat pattern, including dimensions, notes and GD&T symbols. Flat patterns saved with 3D designs can be used to create accurate flat patterns on 2D drawings as well.

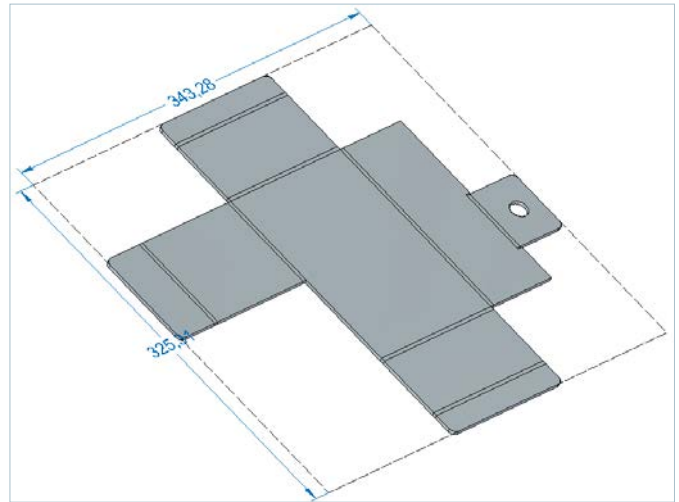

Figure 18: Saving flat patterns with the designed part.¹⁸

2. You can create flat patterns on 2D drawings that are associative to the model. In this case, model changes are reflected in the flat pattern and subsequently updated on drawings, ensuring that the latest flat pattern design modifications make it to the manufacturing stage. While it is possible to place stacked or string dimensions, it is more common on flat patterns to provide ordinate dimensions from a common datum. Typically, 2D drawings are used for manual programming or saved as DXF for machine code.
3. You can use “save flat as DXF” and flat pattern generation commands to create a CAM-ready flat pattern DXF file directly from the sheet metal model without creating a drawing first. This approach is useful when a one-off job needs to be performed quickly, such as during the prototype stage or when machine operators need to rapidly program a CNC machine. Since many machines read DXF directly, this approach is quicker, more convenient and less error prone when manually reading drawings.

These capabilities play a significant role in enabling Solid Edge to automate perhaps the most widely used workflow – the workflow for creating manufacturing-ready files. When a flat pattern is generated, Solid Edge automatically combines collinear lines into a single line. Options are provided to convert spline-based curves produced by corner relief into lines, using a supplied tolerance. The settings are used for all flat pattern generation methods and are intended to provide an NC-ready flat pattern for downstream manufacturing. Users can automatically add corner treatment to prevent dwell burning that can be caused by laser manufacturing machines.

A number of options are available for generating flat patterns Solid Edge facilitates layer mapping. Manufacturing software operators can open a Solid Edge file directly and begin showing critical bend lines or other useful information as each element type is carefully mapped to an appropriate layer.

Solid Edge automatically places chamfer/rounds on inside/outside corners in the flat. This is a time consuming manual process for most other systems. An option to “unbend” all bends enables designers to unfold the whole part without having to select all bends first.

Deformation features Deformation features, such as louvers, dimples and beads, are usually punched or formed during the manufacturing stage but don’t have any impact on the flat pattern. Depending on your shop floor machinery and manufacturing process, Solid Edge lets you represent deformation features in a manner that best suites your manufacturing process, including as an outline, an outline plus center punch marks or just a center mark.

Bend tables Like flat patterns, bend tables can be stored with 3D sheet metal parts and placed on 2D drawings. Bend tables stored within 3D parts allow the bend order to be documented. This provides designers with the freedom to design parts the best way while ensuring manufacturability. Bend tables are also used on drawings. Bend tables can be exported to help program CNC machines, including providing information to represent up and down bends, bend lines and bend angles.

Triangulation lines Solid Edge supports the use of triangulation lines for conical bends – an important enhancement for anyone who creates transitional sheet metal work like square to rounds or conical shapes. These shapes are often formed using a press brake.

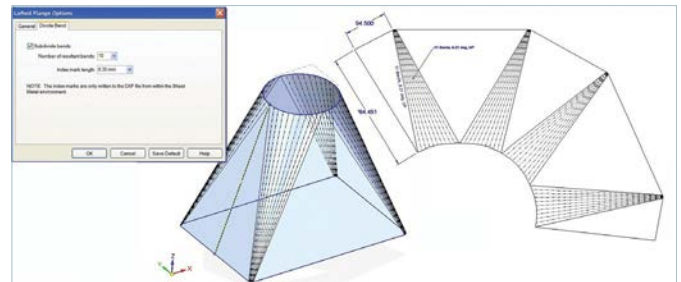

Figure 20: Triangulation lines.²⁰

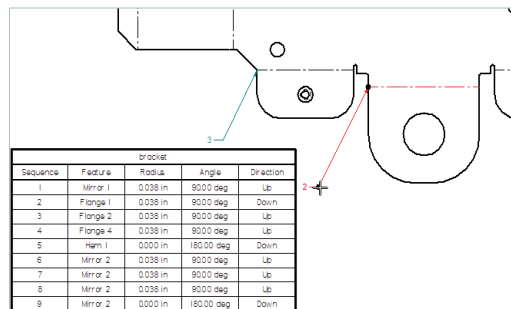

Figure 19: Bend tables.¹⁹

Conclusion

Solid Edge streamlines the entire sheet metal product development process, from design of sheet metal components, through flat pattern development and the creation of engineering drawings. Along with integrated applications for analysis, nesting, NC programming and related tasks, Solid Edge provides the foundation for a complete design-through fabrication solution that helps shrink product lead times, improve quality and reduce costs.

Further reading

Solid Edge with synchronous technology: http://www.plm.automation.siemens.com/en_us/Images/Technicom_SolidEdge_ST_WhitePaper_tcm53-61387.pdf

Solid Edge with synchronous technology 2: http://www.plm.automation.siemens.com/en_us/forms/seform.cfm?doc=http%3A//siemens.pmhclients.com/index.php/solidedgelaunch/%3Fku%3Dtrue%26a%3D9

Glossary

Body – The resulting object to which operations are applied. In most cases, bodies are solids, but they can be sheets (surfaces only) or wires (curves). Bodies do not capture any history of operations or defining constraints to ensure intent. The CAD application is responsible for tracking feature definition.

Bottom-up assembly design – A method in 2D or 3D modeling where parts are created discretely outside the context of the top-level assembly but not by using other assembly components as a guide to define part features, such as holes or faces.

B-REP – Acronym for boundary representation, which is a 3D solid body. It does not capture or track any operations and is the primary object translated between different CAD systems.

Direct editing – A feature used in history-based systems that operate directly on a B-REP model. Direct edit commands typically include move and rotate operations and act only upon a selected face. In general, direct edit operations are captured as features, adding regeneration cycles to the overall process.

Displacement-stress – Results that show mesh and colored displacement contours, which indicate where the model deflects, as well as a scale that shows their related values using units set for the stress analysis, such as mm, cm and inches.

Document – A container of data in the form of a file. Parts, drawings and assemblies are typically stored in documents with different file name extensions. Documents also tend to contain property data, such as part numbers, materials and authors.

Explicit modeling – A modeling concept where operations and their associated history of creation are not captured. Edits are only made directly to the resulting B-REP. Due to lack of “features,” edits such as pattern instance count change can only be made by delete and re-create operations.

Factor of safety – Results that show the mesh and colored factor of safety contours, which indicates areas where the model exceeds the determined factor of safety, as well as a scale that shows by how much a component is within or outside its factor of safety.

Fluent interface – Name that Microsoft gave to its user interface style. This style is found in Office 2007 and the rights to use the Fluent interface must be licensed.

Features – An industry term that refers to how 3D CAD operations are stored. Stored feature definitions tend to include 2D sketches and parameters. In most cases, features are the primary mechanism for making edits. Edits to one feature trigger a regeneration sequence that must delete and recreate any subsequent operation.

History – A technology invented in the 1980s in which operations are stored as features in chronological order, where each feature builds on the previous one. Edits are made by adjusting a feature’s parameters and subsequent operations delete and rebuild.

K factor – Metric used to determine accurate sheet metal blank size for folded parts. Sometimes called the neutral line or neural factor, the K factor is the imaginary line through the material thickness about which material does not change as it is bent. The K factor is different in each material, but for mild steel, it can be considered to be in the middle. Material either compresses or stretches about the K factor.

Mid-surface – A method for analyzing sheet metal parts using 2D plate elements to make the analysis more efficient. Mid-surface results can be displayed using both static and modal analysis.

Mixed mode – Coined by Siemens PLM Software to refer to the capability for parts modeled in different technologies to be created and edited in the same assembly. This method is only available in Solid Edge.

Natural frequency – Results that show the four major natural frequencies of the part and the shape of the part at those frequencies.

Parametrics – Originally invented by PTC to refer to a method for controlling an update process by relating features through a series of constraints. When a feature is edited, all subsequent operations are deleted and regenerated in a cascading order.

Stress – Results that show the mesh and colored stress contours, which indicate areas of stress build up, as well as a scale that shows their related values using units set for the stress analysis, such as kPA, PSI, BAR and many other units.

Synchronous technology – A new design paradigm based on a history-free, feature-based approach that combines the speed and flexibility of explicit modeling with parameterized design. Features can control each other regardless of creation order.

Top-down assembly design – A method in 2D or 3D modeling where parts are created in the context of the top-level assembly, and where geometry is created using other parts as a guide to guarantee fit and position.

Traditional modeling – A term coined by Siemens PLM Software to refer to history-based 3D CAD systems and the methodology used to build or program parts using a system of constraints (this is necessary for parts to regenerate correctly upon a change in any feature definition).

References

1. Synchronous technology is a history-free feature based approach to modeling that combines the speed and flexibility of explicit modeling design.
2. With no specialized commands to learn, Solid Edge with synchronous technology's "grab and go" design philosophy provides design freedom that allows you to focus on your design ideas instead of learning how drive the CAD system.
3. Synchronous technology enables you to select, edit or delete features with no model regeneration or performance penalty.
4. Specialized sheet metal capabilities allow you to establish, maintain and edit design intent without expensive model regeneration.
5. Live Rules eliminate the need to apply complicated geometric relationships. As a result, intelligent models can be developed even if no relationships are used during the creation process.
6. 3D Driving Dimensions let you add inside or outside dimensions to establish rules as and when they are known.
7. By adopting an independent feature design, you can edit the first operation as fast as the last. With synchronous technology, engineers can edit a latter flange and drive the location of the flange created earlier. Unrelated geometry is not regenerated, so model performance is much faster.
8. Being able to edit imported data helps reduce supplier change fees as edits to outsourced data can be made in-house. Solid Edge with synchronous technology can take imported sheet metal model files and convert them to usable parts where edits can be made as though they were native files.
9. Solid Edge with synchronous technology, uniquely retains dimensions on 2D drawing views to drive 3D geometry.
10. Solid Edge with synchronous technology, uniquely retains dimensions on 2D drawing views to drive 3D geometry.
11. Unique Live Sections let you better visualize and address interferences between parts. Just cut a section view through any part of the model and directly edit the resulting 2D cross section
12. Defining material properties allows you to easily make fast global changes to material thickness, bend/cutout relief and bend radii, while preserving inside or outside dimensions.
13. Sheet metal sensors in Solid Edge dynamically monitor critical design rules and parameters to ensure that parts don't break design rules and that they can be manufactured.
14. Sheet metal sensors in Solid Edge dynamically monitor critical design rules and parameters to ensure that parts don't break design rules and that they can be manufactured.
15. Solid Edge sheet metal simulation capabilities deliver fast accurate results that reduce the need for physical prototypes. They also save time and cost and improve quality while allowing you to optimize materials.
16. Solid Edge highly productive drawing capabilities include associative drawing views, section views, exploded views, dimensions, GD&T machining symbols, bend tables, bill of materials, auto ballooning and other functionality that complies with popular internationally recognized standards.
17. Solid Edge includes an industry standard formula for flat pattern development. A custom formula can also be set, offering maximum compatibility with your manufacturing process.
18. Solid Edge flat patterns can be saved with the folded "designed" part. Blank size is automatically calculated. Sensors can warn if the standard stock sheet size is too small.
19. In Solid Edge, bent tables can be used to report bend radii and direction. This information can also be used for help program CNC folding machines.
20. Handy "triangulation lines" (output from Solid Edge) are a helpful guide for fabricators folding transition pieces, such as shutes and square to rounds.

Siemens PLM Software

Headquarters

Granite Park One
5800 Granite Parkway
Suite 600
Plano, TX 75024
USA
+1 972 987 3000

Americas

Granite Park One
5800 Granite Parkway
Suite 600
Plano, TX 75024
USA
+1 314 264 8287

Europe

Stephenson House
Sir William Siemens Square
Frimley, Camberley
Surrey, GU16 8QD
+44 (0) 1276 413200

Asia-Pacific

Suites 4301-4302, 43/F
AIA Kowloon Tower, Landmark East
100 How Ming Street
Kwun Tong, Kowloon
Hong Kong
+852 2230 3308

About Siemens PLM Software

Siemens PLM Software, a business unit of the Siemens Industry Automation Division, is a world-leading provider of product lifecycle management (PLM) software, systems and services with nine million licensed seats and 77,000 customers worldwide. Headquartered in Plano, Texas, Siemens PLM Software helps thousands of companies make great products by optimizing their lifecycle processes, from planning and development through manufacturing and support. Our HD-PLM vision is to give everyone involved in making a product the information they need, when they need it, to make the smartest decisions. For more information on Siemens PLM Software products and services, visit www.siemens.com/plm.

www.siemens.com/plm

© 2014 Siemens Product Lifecycle Management Software Inc. Siemens and the Siemens logo are registered trademarks of Siemens AG. D-Cubed, Femap, Fibersim, Geolus, GO PLM, I-deas, JT, NX, Parasolid, Solid Edge, Syncrofit, Teamcenter and Tecnomatix are trademarks or registered trademarks of Siemens Product Lifecycle Management Software Inc. or its subsidiaries in the United States and in other countries. All other logos, trademarks, registered trademarks or service marks belong to their respective holders.

4379-Y4 8/14 B