

# What's new in Solid Edge with Synchronous Technology 2

## fact sheet

Siemens PLM Software

www.siemens.com/solidedge

### ► Summary

Solid Edge® software with synchronous technology 2 continues to build on the innovative synchronous technology design paradigm first seen last year. This version deepens the initial implementation to handle more design scenarios and introduces a new synchronous technology-based sheet metal application that proves synchronous technology can be extended throughout Solid Edge. These enhancements – when combined with a new, robust, built-in finite element analysis application and an update of Solid Edge Insight™ software – allows Solid Edge with synchronous technology 2 to continue to deliver up to a 100x faster modeling experience and more.

### Benefits

*Synchronous technology extensions to part and assembly*

Experience up to 100x faster design

*Synchronous technology for sheet metal*

Achieve faster modeling, with less preplanning

Gain unbounded edit flexibility for quicker changes

Re-use more data with the ability to edit any data

*Solid Edge Simulation*

Lower product costs

Cut material costs

Improve product quality

Require fewer physical prototypes

*Insight (design data management)*

Leverage Microsoft SharePoint for business integration

Improve productivity for daily design tasks

Minimize implementation and ongoing support costs

Realize low total cost of ownership

*Solid Edge Embedded Client*

Achieve seamless integration with industry-leading cPDM

Drive faster project completion

### Introduction

Building on a groundbreaking technology, Solid Edge with synchronous technology 2 continues to take customer responsiveness to the next level. This exciting new release:

- Extends the capabilities of synchronous technology for part and assembly modeling
- Adds a new synchronous technology-based sheet metal design application
- Includes a new built-in FEA simulation capability for design engineers
- Reinforces our scalable product data management strategy by moving Solid Edge Insight to the latest Microsoft SharePoint platform and improved integration with Teamcenter® Express software
- Delivers many customer-driven enhancements for traditional modeling and synchronous technology.

### Extends synchronous technology for part and assembly

Synchronous technology has been extended even deeper into part and assembly modeling with support for a number of new features including:

- 2D dimensions migrate from drawings to become 3D driving dimensions
- Live sections for editing of 3D models using 2D cross sections
- History-free, sketch-based edits to Helix features, blend reordering and more

These enhancements collectively continue to drive Solid Edge to deliver up to a 100x faster design experience.

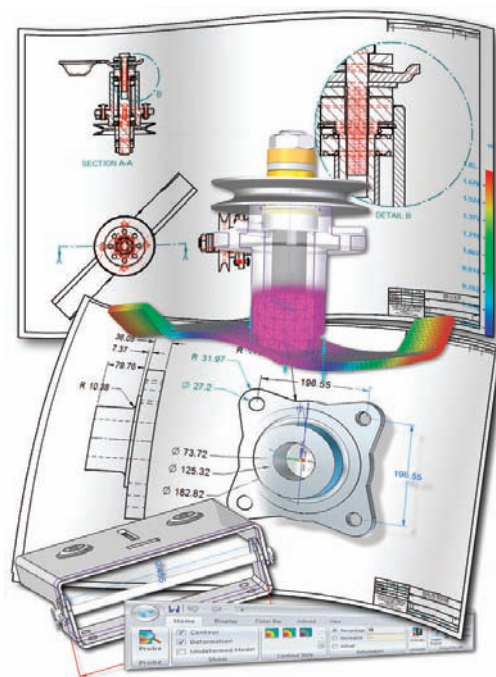

## Features

*Synchronous technology extensions for part and assembly*  
 Migrate 2D dimensions in create 3D  
 2D cross-section editing  
 Sketch-driven procedural features  
*Synchronous technology for sheet metal*  
 Grab-n-go tools for quicker model development  
 History-free feature-based modeling and editing  
 Sheet metal-based procedural features  
 Feature libraries designed for sheet metal  
 Live Rules tuned for sheet metal  
 3D driving dimensions and relationships  
 3D stretching  
 2D section editing  
*Solid Edge Simulation*  
 Familiar process-oriented Solid Edge user interface  
 Finite element modeling for design engineers  
 Industry standard NX™ Nastran® solver software  
 Part, sheet metal and realistic assembly contact modeling  
 Maintain loads and restraints during model changes  
*Insight (design data management)*  
 Harnesses the power of Microsoft SharePoint  
 PDM functionality embedded in Solid Edge  
*Solid Edge Embedded Client*  
 Synchronized releases with Solid Edge  
 Comprehensive attribute mapping  
 Smart codes

Use the create 3D command to migrate 2D data to 3D. Here 2D dimensions are automatically replaced with editable 3D driving dimensions during model creation. This process works with most popular 2D drawing formats such as AutoCAD and other formats through DXF. Other 3D CAD systems that migrate 2D drawings to 3D lose the dimensions in the process. Solid Edge preserves your investment in 2D drawings, while realizing immediate value with 3D.

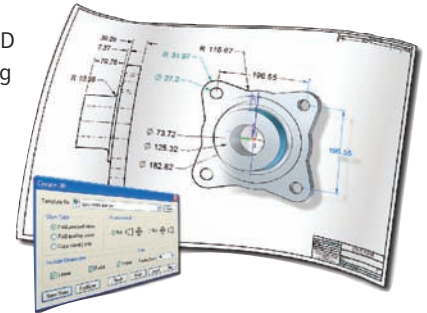

Change 3D models by editing user-defined 2D cross sections with new live sections. Intuitive 2D section editing allows you to edit multiple cross sections in different views and change parts from within your assemblies. Edits to 2D cross sections immediately update the 3D model and give greater flexibility in making changes because edits are not limited by creation rules inherit with history-based systems. This unique capability means you can better visualize and address interferences between parts as easily in 3D as you're used to in 2D.

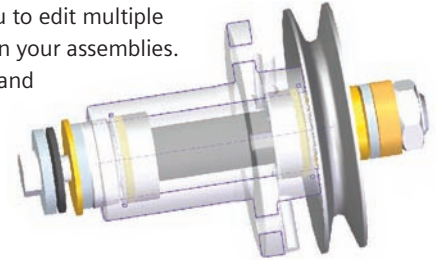

Helices can be edited directly from underlying sketches without any downstream model regeneration using procedural features originally introduced in Solid Edge with synchronous technology. History-free feature-based editing provides feature edits through parameters, but avoids lengthy model regeneration.

Other new advancements continue to drive higher productivity and greater control. For example, you can now change the blend order to obtain a different result at blend intersections. Drafted faces can be edited by the original draft angle regardless of other changes to the model.

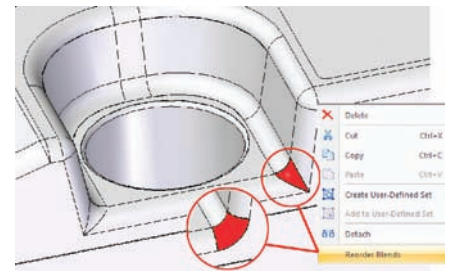

All this and more just goes to show synchronous technology provides the most advanced direction for the future of CAD.

## Synchronous technology applied to sheet metal design

A major addition is the application of synchronous technology to sheet metal design. This capability extends the power of synchronous technology beyond traditional part and assembly modeling and is proof-positive that many Solid Edge applications will one day be able to take advantage of synchronous technology.

Using the new sheet metal application, designers can develop and edit models using our unique history-free feature-based 3D design approach for modeling straight brake sheet metal parts. With a unique direct interaction paradigm, models can be created with few or no commands, avoiding preplanning when creating new designs. 3D driving dimensions and Live Rules provide unbounded edit performance and flexibility for faster changes, and all modeling tools work equally effectively on imported parts, resulting in lower change costs through increased re-use of supplier data.

*Synchronous technology delivers faster sheet metal model development.* Direct interaction paradigm with sheet metal-specific grab-n-go tools allows you to develop sheet metal parts quicker than ever. Geometric handles specially designed to streamline sheet metal component design mean you can create

and manipulate models faster with few or no commands and less preplanning. With the inherent fluidity of synchronous design, you can instantly drag regions from sketches or imported 2D drawings, pull sheet metal regions into tabs or corner conditions, and effortlessly move rotate or align faces – all while maintaining key parameters including material thickness. History-free feature-based modeling means sheet metal operations are stored as a feature collection and not in a linear tree. These features can be used to manage design intent, aid geometry selection and be moved reordered or sorted, without forcing model regeneration. History-based systems require time-consuming model regeneration with the simplest of operations.

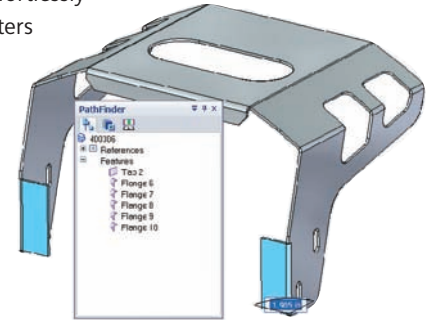

Sheet metal-specific procedural features allow you to make history-free feature edits through sketches or parameters and avoid model regeneration. With procedural features you can edit cutouts that cross bends using sketches that originally defined their shape. Deformation features such as dimples, louvers and gussets etc. can be changed by adjusting key parameters. Pattern count, size and shape of any instance can easily be changed, allowing you to establish, maintain and edit design intent without expensive regeneration.

*Edit sheet metal components faster with synchronous technology.* With Live Rules tuned for sheet metal, model conditions are maintained with or without constraints. Live Rules automatically find and maintain geometric conditions while dragging or making dimensional edits, all while maintaining sheet metal conditions such as thickness, bends and reliefs. History-based systems require application of constraints during modeling in order to make future edits, which slows development and locks out the ability to make unplanned changes. Live Rules work directly on the completed model and provides boundless edit flexibility.

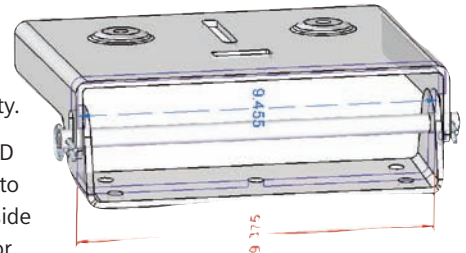

Make dimensional edits with 3D driving dimensions and 3D model relationships. 3D driving dimensions can be added to completed models to control factors such as inside or outside material conditions with full support for dynamic, locked or equation-based dimensions with directional control. To add more design control, geometric constraints such as parallel or perpendicular can be easily added, and even locked to maintain design intent, so you can make unplanned changes as needed. Because features are independent, you can modify sheet metal operations regardless of creation order so you can edit the first operation as fast as the last.

*Synchronous technology streamlines sheet metal geometry re-use.* Edit sheet metal designs not created in Solid Edge faster than the original system. Turn imported 3D geometry into editable sheet metal parts where key parameters such as thickness, bends and bend radii are recognized and maintained. Continue modeling on imported geometry by adding sheet metal features, and make edits by simply pushing/pulling on flanges or by using 3D driving dimensions. History-based systems require complete remodeling or paying supplier change fees for alterations. These powerful capabilities help you re-use and leverage legacy, customer or supplier data more effectively.

*Work in 3D with the simplicity of 2D using synchronous technology.* Get the power of 3D, while retaining the simplicity of 2D. Most designers are familiar with 2D design concepts such as stretching, and with synchronous technology those same concepts can be used in 3D. While stretching, critical conditions such as thickness bend radius, locked dimensions and geometric conditions are preserved. Users can also make 2D-like edits with the use of live sections, where edits to any cross section can be used to instantly update the 3D model. History-based 3D forces users to understand and manipulate features, or remodel the part. These powerful edit commands help you visualize and address interferences between parts.

### Solid Edge Simulation

Solid Edge Simulation is a new, easy-to-use, built-in finite element analysis tool for design engineers to digitally validate designs within the Solid Edge environment. Based on proven Femap® finite element modeling technology, Solid Edge Simulation significantly reduces the need for physical prototypes, thereby reducing material and testing costs, while saving design time.

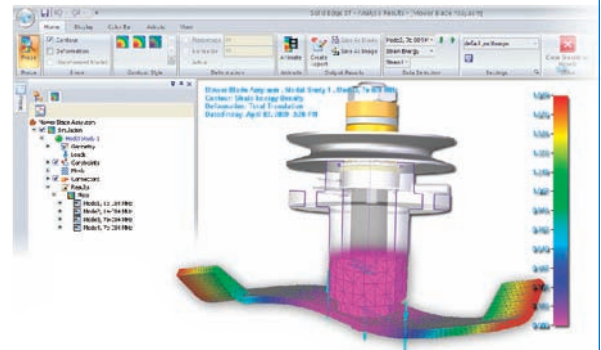

*For use by design engineers.* An optional, built-in Solid Edge application uses the same underlying geometry and user interface as all Solid Edge applications. Solid Edge Simulation is easy enough for any Solid Edge user with a fundamental understanding of FEA principles, yet robust enough to service most of your analysis needs. By allowing capable engineers to perform their own analysis, more analysis gets done in less time – improving quality, reducing material costs and minimizing the need for physical prototypes without incurring the high costs of outsourced analysis.

*Automatic finite element model creation.* Create and refine finite element meshes. Solid Edge Simulation supports solid tetrahedral element meshes as well as two-dimension shell element meshes on sheet metal structures. You can fine tune the finite element mesh with manual edge and face element sizing, and a mesh size slider bar that makes element size adjustments to the overall mesh, for an efficient simulation model that delivers accurate results.

*Full complement of load and constraint definitions.* Produce accurate results. Solid Edge Simulation provides all of the boundary condition definitions that you'll need to define realistic operating environments. The constraints are geometry based and include fixed, pinned, no rotation, symmetric and cylindrical variations. The loads are also geometry based and include mechanical as well as temperature loading for thermal analyses. Solid Edge Simulation facilitates load and constraint application with Quick Bar input options and handles for direction and orientation definition.

*Analyzing assemblies.* Connect assembly components together fast. Assembly contacts include component to component, in an iterative linear solution, and glued connection of individual components. Contact detection between components can be determined automatically, or connector defined individually through manual face selection. Assembly materials and properties can be applied manually or by default, while the included NX Nastran solver assures realistic assembly component interaction, making for a robust solution.

**Analysis types.** Undertake statics, modal and buckling analyses using the industry accepted NX Nastran solver for reliable results. Re-use of finite element model loads and constraints is as easy as dragging and dropping from one study to another.

**Analysis scalability.** From Solid Edge Simulation Express (formerly Femap Express) for individual parts, through Solid Edge Simulation which extends simulation to assemblies, all the way to Femap with NX Nastran that allows you to define and analyze complete systems, the complete line of products is associative and compatible.

**Postprocessing.** Interpret and understand the resulting model behavior quickly with the comprehensive graphical post-processing tools. Model results can be displayed in a number of forms, including color and contour plots, and displacement and mode shapes that can be animated. You can quickly identify problem areas and display max/min stress markers, as well as generate a report of final results.

**Design updates.** Post analysis you can make any required design updates quickly and easily. Synchronous technology lets you make history-free feature-based model changes at will, which drastically speeds up the model refinement process. Furthermore, Solid Edge Simulation maintains associativity between the CAD and FE models, and makes sure that your applied loads and constraints are maintained for all model changes.

### Product data management

**Solid Edge Insight.** This tool is the first design data management solution to harness the ease of use and low total cost of ownership of Microsoft's SharePoint business productivity platform. Since 2001, thousands of Insight users have benefited from its seamless integration with Solid Edge, efficient design release process and web portal for improved collaboration. With this release, Insight is now available on Windows SharePoint Services (WSS) 3.0 and Microsoft Office SharePoint Server 2007. WSS is included with Windows Server 2003 and 2008 so Solid Edge customers already have the basic components in place for easy implementation. These latest Microsoft platforms deliver improved collaboration, workflow and security capabilities to Insight users resulting in more efficient and higher quality completion of design projects.

**Solid Edge Embedded Client.** Provides transparent integration between Solid Edge and the collaborative product data management environments of Teamcenter and Teamcenter Express. With this latest synchronized release, users benefit from improved performance for handling assemblies and linked parts, intelligent part numbering through smart codes and more comprehensive attribute mapping.

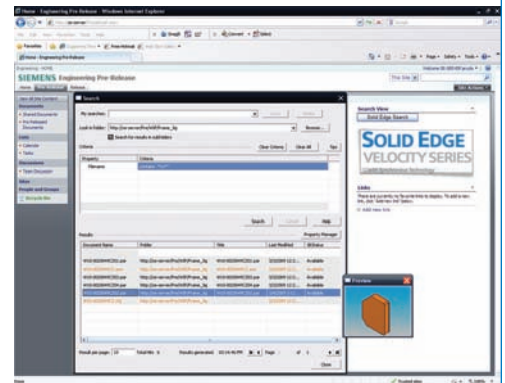

► For more information, contact your local Velocity Series™ portfolio representative:

► Contact  
 Siemens PLM Software – [www.siemens.com/solidedge](http://www.siemens.com/solidedge)  
 Americas 800 807 2200  
 Europe 44 (0) 1202 243455  
 Asia-Pacific 852 2230 3308

**SIEMENS**