

NX I-deas Master Notation

For documenting solid model designs

Benefits

- Designs in Master Modeler and Master Assembly can be fully documented in 3D, eliminating the need for 2D drawings
- Annotation can be attached and associated to multiple geometric entities, and subsequent queries of the annotation or geometry will highlight these associations, providing design intent not available in standalone documentation
- Organization of annotation with model views and model view folders makes the 3D product easier to document and interpret
- Model views provide for creation of 2D drawings in NX I-deas Master Drafting, preventing duplicate effort when some downstream users require drawings
- Model views may be exported from NX I-deas, and used in various other applications for viewing the model and its associated 3D annotation

Features

- Comprehensive set of annotation tools for documenting parts and assemblies

Summary

NX™ I-deas™ Master Notation is a 3D annotation system within NX I-deas software for documenting solid model designs created in NX I-deas Master Modeler or NX I-deas Master Assembly. Master Notation can be used as a documentation tool in two basic ways:

- As a tool for creating fully documented solid models for design review or release, without the need to create drawings
- As a tool for documenting solid models created in NX I-deas, in preparation for quickly creating drawings

Annotation tools

Master Notation provides a palette of annotation tools that can be used within Master Modeler for documenting parts, or for use within Master Assembly for documenting assemblies. Master Modeler and Master Assembly provide capabilities

for adding key/driving dimensions, annotation dimensions and notes to the design.

Master Notation provides optional capabilities with additional annotation symbology and organizational tools. These capabilities include geometric dimensioning and tolerancing, surface attributes, multiple text fonts and user-definable text sizes,

plus the ability to link annotation to information on the web. These are available for documenting individual parts as well as assemblies, with support for conformance to multiple international standards.

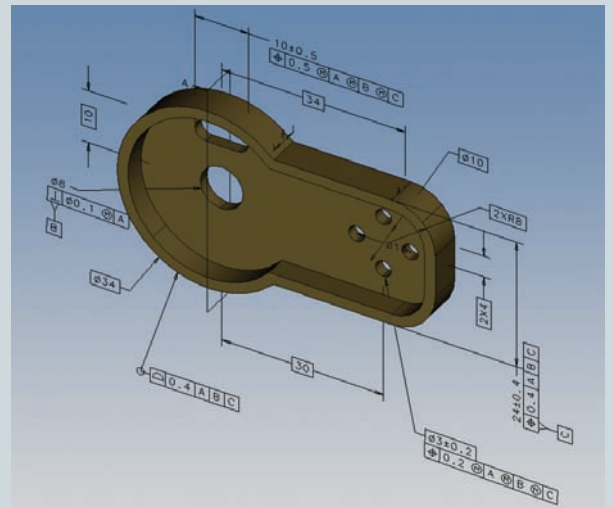

Master Notation provides tools to fully document designs in 3D, eliminating the need for 2D drawings.

NX

www.siemens.com/nx

SIEMENS

NX I-deas Master Notation

Features *continued*

- Annotation can be attached and associated to geometry
- Easy organization of annotation with model views and model view folders
- Integration with Master Drafting for creation of 2D drawing, if desired

Association and attachment of annotation

A critical aspect of 3D annotation is its ability to attach and track the appropriate geometry. Master Notation provides many ways to attach annotation, with or without leaders or stacked upon other symbols or notes. NX I-deas goes beyond simple attachment, and also provides the user an opportunity to select other associated geometry as well. It is a simple task to query annotation and see what geometry it is associated to. For example, a user may associate a feature control frame (FCF) to the actual surfaces of datum A and datum B. When another user queries the FCF, the surfaces of datum A and B are highlighted, making interpretation very obvious. On the other hand, the user may query the surface of datum A, and the associated FCF will highlight. This additional characteristic of association may be added to any 3D annotation in NX I-deas, and provides the strong addition of design intent that standalone annotation cannot convey.

Organization with model views

Master Notation also provides the ability to organize annotation into model views. Model views are a unique tool in 3D that provide the ability to store a specific viewing direction and zoom factor for the part or assembly. This is very similar to the views that may typically be created for

organizing the information on a 2D drawing. Model views are also individual repositories for specific annotation. In typical CAD systems, there is only one large intertwined tangle of 3D annotation, all together on the single CAD model. Model views in NX I-deas alleviate this problem, and allow for very organized collections of annotation, making the 3D product easier to document and interpret. Model views provide many capabilities for organizing your 3D documentation:

- Standard orthographic views, with the ability to track geometry
- Automatically distributed annotation among standard views
- Explicit views for creating detail or auxiliary views
- 3D section views, with cross-hatching and color-coding of cut surfaces
- Full modification capabilities: rename, copy, move, re-track, etc.
- Easily add or remove annotation from model views
- Composite display allows annotation from multiple model views to be displayed at the same time
- An unlimited number of model views may be created
- Geometry from design groups can be used to show only specific geometry of interest within a model view
- Model views are stored with their parent part or assembly
- Individual model views may be printed or plotted directly from NX I-deas

Additional organization with model view folders

Model view folders are an additional organizational tool that allows the model views to be organized for a specific purpose. Folders may be created that hold model views specific to downstream users, to highlight certain aspects of the design or to isolate different kinds of annotation.

For example, a company may have a specific folder containing all model views of weld symbols, a folder containing all model views of surface finish marks or a folder containing all model views for the inspection department. The organizational needs for 3D annotation are unlimited, and therefore NX I-deas provides an unlimited number of model views and model view folders.

Integration with Master Drafting

The utility of model views does not stop with 3D documentation. Any model views that are created for a part or assembly can be accessed directly from within Master Drafting. Here, the user can select model views, preview them in a separate window and select which ones to place on the active drawing. Master Drafting will automatically create the hidden lines for each model view. The specific annotation for each model view is also displayed in the view on the drawing. This provides one way to create a drawing that documents the solid design.

- Access to part and assembly model views from Master Drafting
- Associativity to the model views allows you to change the 3D annotation on the solid model and automatically update the drawings at the user's discretion
- Different model views from different parts and assemblies may be placed on the same drawing
- Annotation may be added to any view on the drawing to complete the documentation, or add more information
- Automatic hidden line creation, either removed or dashed

Prerequisites

Master Modeler or NX I-deas Product Design Package or NX I-deas Artisan Series

Contact
Siemens PLM Software
Americas 800 498 5351
Europe 44 (0) 1276 702000
Asia-Pacific 852 2230 3333

www.siemens.com/nx

© 2011 Siemens Product Lifecycle Management Software Inc. All rights reserved. Siemens and the Siemens logo are registered trademarks of Siemens AG. D-Cubed, Femap, Geolus, GO PLM, I-deas, Insight, JT, NX, Parasolid, Solid Edge, Teamcenter, Tecnomatix and Velocity Series are trademarks or registered trademarks of Siemens Product Lifecycle Management Software Inc. or its subsidiaries in the United States and in other countries. All other logos, trademarks, registered trademarks or service marks used herein are the property of their respective holders.
X1 10802 2/11 B