

Siemens PLM Software

NX Advanced Thermal

Extend thermal analysis solutions

Benefits

- Extend thermal solution capabilities in NX Thermal and NX Electronic Systems Cooling
- Solve complex heat transfer phenomena with a comprehensive set of modeling tools
- Reduce costly physical prototypes and product design risk through high fidelity thermal simulation
- Gain further insight through coupled thermo-fluid multi-physics analysis using NX Advanced Thermal with NX Flow or NX Advanced Flow
- Leverage all the capabilities of the NX integrated environment to make quick design changes and provide rapid feedback on thermal performance

Summary

NX™ Advanced Thermal software extends the modeling and simulation capabilities of NX Thermal or NX Electronic Systems Cooling. NX Advanced Thermal provides a wide range of methods for advanced radiation analysis, radiative and electrical heating models, advanced materials models such as phase change, charring and ablation, as well as one-dimensional hydraulic network modeling. Thermo-fluid coupling is enabled with NX Flow and NX Advanced Flow, and thermo-elastic effects can be simulated by mapping temperature results to NX Nastran® software.

NX Advanced Thermal continues Siemens' long heritage in thermal simulation and leverages the same technology that underpinned the I-deas™ TMG solution. NX Advanced Thermal adds a rich feature set to the powerful

simulation technology of NX Thermal. Intended for tackling complex thermal physics and challenging thermal management problems, NX Advanced Thermal offers the same best-in-class level of integration within the NX preprocessing, postprocessing and simulation tools.

Applications of NX Advanced Thermal include simulation and analysis of a range of heat transfer problems in aerospace, automotive, electronics, power, process and other industries. NX Advanced Thermal offers the following additional features on top of the NX Thermal license.

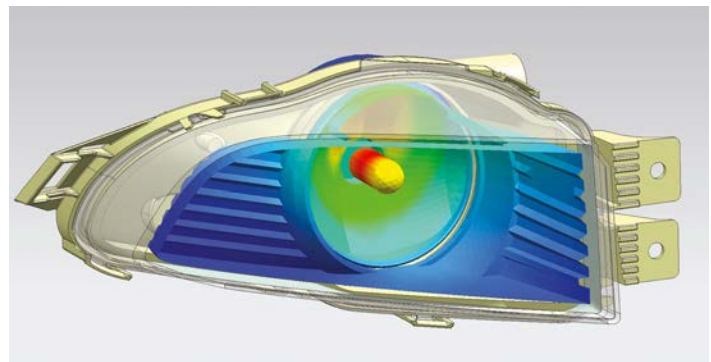

NX Advanced Thermal

Advanced optical properties

- Specular reflectivity, diffuse and non-diffuse transmissivity, index of refraction, solid absorption
- Direction-dependent optical properties, BRDF
- Wavelength-dependent properties for nongray analysis

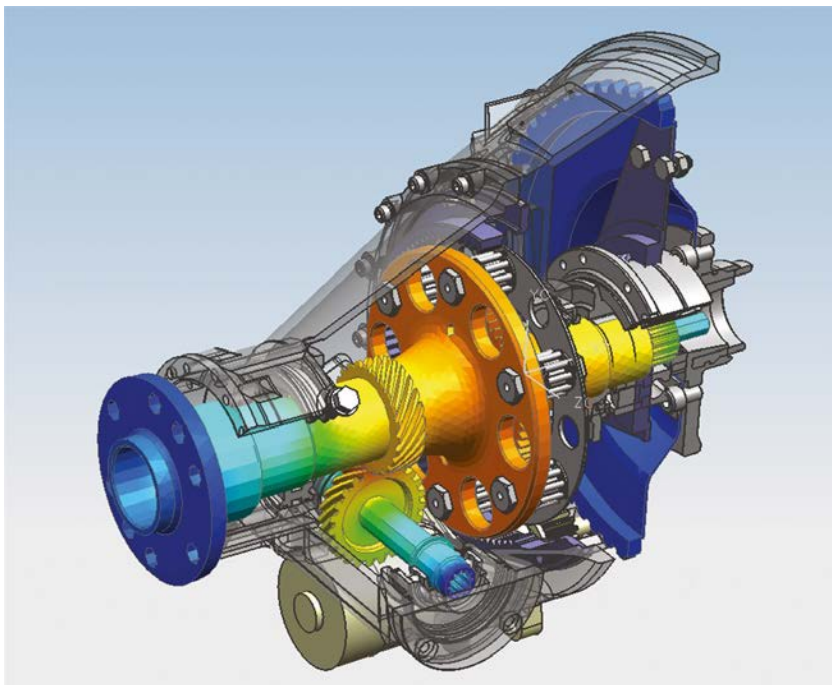
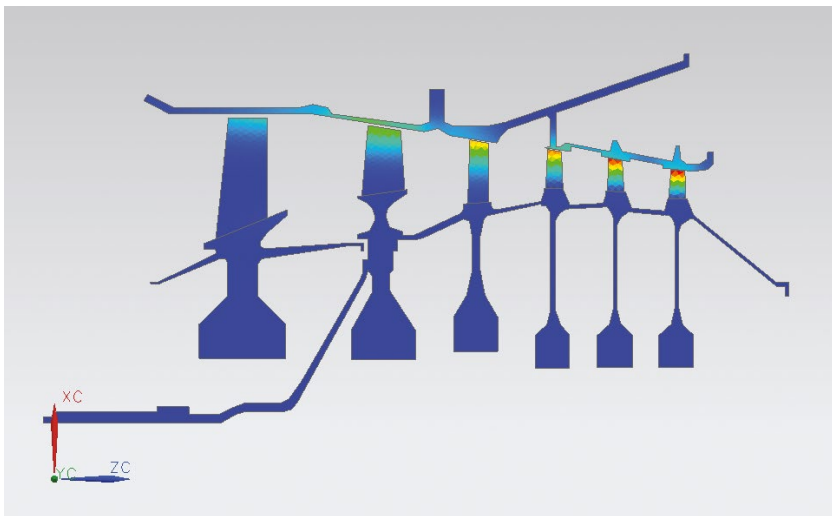

Advanced material models

- Ablation and charring models
- Electrical resistivity and Joule heating

Advanced radiation methods

- Deterministic and Monte Carlo ray tracing
- Nongray multiband radiative heat transfer

Radiative heating

- Solar heating with atmospheric attenuation and albedo flux models
- Radiative source definition, collimated or diffuse, spectrum-dependent, time and spatially varying flux

1D hydraulic network modeling

- 1D flow modeling using duct networks
- Ability to simulate convection to and from 1D duct networks
- Film cooling model
- Linear or exponential advection discretization

Advanced thermal couplings

- Perfect contact
- One-way conductances
- Free and forced correlation-based convection couplings
- Convective gap couplings
- User-defined couplings
- Cyclic symmetry couplings

Articulation and motion modeling

- Any combination of translational motion and rotational joints
- Time-dependent radiation and thermal couplings
- Postprocessing of articulated mesh
- Solid Motion Effects toolset which includes articulation and spinning effects

Thermal control devices

- Peltier cooler models
- Active heater controllers, PID controllers

Multiphysics environment support

NX Advanced Thermal enables the multiphysics environment to solve thermo-mechanical problems in loosely (one-way) or tightly-coupled (two-way) modes.

This environment delivers a consistent look and feel for performing multiphysics simulations so you can easily build coupled solutions on the same mesh using common element types, properties, boundary conditions, as well as solver controls and options.

Coupled thermal-structural analysis enables you to leverage the NX Nastran SOL 401 multi-step nonlinear solver and a thermal solution from the NX Thermal solver.

Open architecture

- Full access to thermal system equations
- Incorporation of external models
- Enhanced solution control
- User subroutines for integration of custom code in the solution sequence

Parallelized radiation solver

- Parallel view factor calculations and flexible thermal solver multi-threading based on the number of available cores for solution efficiency
- The NX Advanced Thermal product includes access to up to 8 cores on one machine for the supported solver modules
- The available NX Thermal/Flow DMP add-on removes any software limitations on the number of cores and enables network and cluster support
- Distributed memory (MPI) based parallelization for highly scalable computation of view factors and radiative heating – available with the NX Thermal/Flow DMP add-on

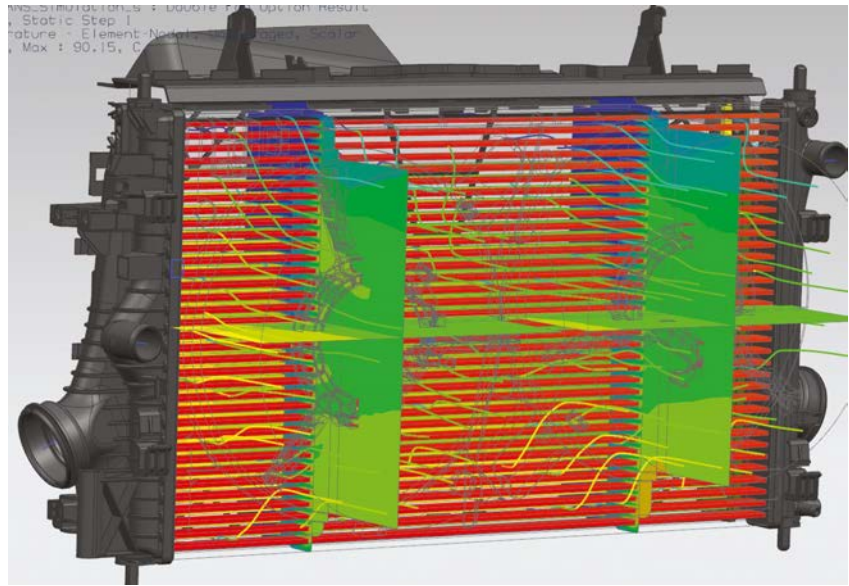

You can conduct coupled thermo-flow analysis without the need to transfer data between multiple software tools.

Supported hardware/OS

NX Advanced Thermal is an add-on module to either NX Advanced FEM or NX Advanced Simulation. It requires a license of NX Thermal as a prerequisite. All standard NX hardware/OS platforms are supported (including Windows, Linux and selected 64-bit platforms). Contact Siemens PLM Software for any other specific hardware/OS support requests.

Contact

Siemens PLM Software

Americas +1 314 264 8499

Europe +44 (0) 1276 413200

Asia-Pacific +852 2230 3308

www.siemens.com/plm

© 2015 Siemens Product Lifecycle Management Software Inc. Siemens and the Siemens logo are registered trademarks of Siemens AG. D-Cubed, Femap, Fibersim, Geolus, GO PLM, I-deas, JT, NX, Parasolid, Solid Edge, Syncrofit, Teamcenter and Tecnomatix are trademarks or registered trademarks of Siemens Product Lifecycle Management Software Inc. or its subsidiaries in the United States and in other countries. NASTRAN is a registered trademark of the National Aeronautics and Space Administration. All other logos, trademarks, registered trademarks or service marks belong to their respective holders.
10623-Y4 1/15 B