

## ARC CASE HISTORY

By ARC Advisory Group

JANUARY 2009

### The use of Information as a Strategic Driver for Sustainable Growth: Unilever, a Case Study



## A Challenging Business Environment

---

The food and beverage, home and personal care, and other fast moving consumer goods industries (FMCG) continue to experience increasingly rapid change, limited resources, greater business risk, and more complexity in every aspect of their business and manufacturing operations.

The fast moving consumer goods industries (FMCG) continue to experience increasingly rapid change, more limited resources, greater business risk, and more complexity in every aspect of their business and manufacturing operations.

Manufacturers find themselves caught between slow growth in traditional markets, rising costs, waning pricing power, accelerated regulatory and customer requirements, and a growing percentage of sales from a limited number of powerful and demanding retailers.

The increase in global competition and the growth of powerful retailers has provided consumers with a wide variety of choices and put tremendous pressure on margins. Powerful retailers like Wal-Mart and Tesco account for a growing percentage of the total sales of most leading manufacturers, often exceeding 30 percent of total sales. Rising and fluctuating energy, material, and ingredient costs put additional pressure on margins. Limited availability of materials and ingredients requires ingredient substitutions which add complexity and increase costs.

Faced with an already wide variety of choices, value conscious consumers are demanding an even wider variety of higher quality, safe, and more convenient products. Powerful retailers are also placing new product specification requirements on manufacturers and expecting more innovative and responsive supplier partnerships. Each of these retailers has their own requirements which differ from their competitors. Demographics continue to change as well. Average life expectancy is increasing and with it a growing population of seniors whose needs have yet to be met. The U.S., Canada, and Europe are experiencing a tremendous growth in Asian,

Over the next few years consumer spending in developing markets such as China, Asia, Africa, and Latin America will overtake developed countries in terms of purchasing power parity.

Middle East, and Spanish speaking, and other ethnic populations. We are experiencing continued urbanization as more of the world's population migrates to large cities. For the first time in history more people are living in large cities than in rural areas. Faced with slow growth in mature markets, manufacturers have been expanding rapidly in less mature market such as China,

Asia, Africa, and Latin America. These countries and geographies have

different and more limited distribution channels. They also have cultural and economic differences from the more traditional markets in the U.S. and Europe. However, over the next few years consumer spending in these markets will overtake developed countries in terms of purchasing power

The increasing power of mass retailers, increasing urbanization, and continued growth of more affluent consumers are some of the factors creating a growing proliferation of SKUs and the trend toward mass customization.

parity. In every market we are experiencing increased urbanization and a growth in more “affluent” consumers. It is estimated that over 350 million people will be living in mega cities by 2015 and that for the first time in history there will be more people living in mega cities than in rural areas.

These are among some of the realities that have created a growing proliferation of SKUs and the need to speed innovation and time-to-market. These have become major challenges for FMCG companies, many of whom have yet to build the infrastructure to support the explosion of information required to support each product in the portfolio and the new business model. The new paradigm is to maintain the efficiencies of large-scale production environments while supporting continuous change and much larger absolute variety. The term “mass customization” is often used to describe a key aspect of this trend.

Product quality due diligence also continues to increase. Global sourcing and distribution, increasingly rapid distribution, and the age of instant information can make even a minor non-life threatening product quality incident devastating to a company. Despite all the efforts deployed to ensure optimum product quality and all the precautions taken every day, incidents do occur where inappropriate products reach consumers. Such products must be rapidly identified, located, and removed from the market. Consumer confidence must be maintained and financial impact minimized. It is generally accepted that a company has 24 hours to identify the scope of the incident and provide an effective response plan in order to maintain consumer confidence. Lacking enough granular information, most

Global sourcing and distribution, increasingly rapid distribution, and the age of instant information requires ever increasing product quality due diligence.

companies broaden the scope of a product recall to ensure the products do not reach consumers. More granular traceability is needed so that manufacturers can limit financial loss and better maintain consumer confidence in the company and the brand. The rise of global terrorism, the growth of product counterfeiting, and the increasing

number of high profile incidents add to the continuing increase in business and brand value risk.



Global interdependency, increasingly limited resources, and environmental concerns have given rise to an ever increasing number of regulations, the need for socially responsible sustainable manufacturing, and the “green” consumer. These are all issues that the FMCG industries must and are addressing within individual companies and with industry-wide initiatives. For example, EU Directive 2001/95/EC on General Product Safety in December 2001, and EU Regulation 178/2002 on Food Safety in January 2002 brought about a significant change in the requirements for product safety. In response, the Efficient Consumer Response Consortium of EU manufacturers of which Unilever is a member developed and published recommendations and best practices for implementing a common plan to meet these requirements entitled, “ECR – Using Traceability in the Supply Chain to meet Consumer Safety Expectations.” There are many governmental, non-government organizations (NGOs), and internal sustainability initiatives underway. Almost every FMCG company has a plan in effect to reduce the carbon footprint of their facilities and their products and to reduce the impact of all of their business activities on the environment. The most visible to the consumer are the “green packaging” initiatives of major retailers such as Wal-Mart and Tesco. However there are many NGOs that are helping to support this effort through audit and certification processes, such as the Rainforest Alliance and Carbonfund.org. This is also being driven by the vastly more limited energy and water resources in many of the emerging markets and the emergence of the “green” consumer. Many surveys suggest that over 50 percent of consumers consider “green” in their purchasing decisions and 20 percent are ardent “green” consumers, whose concern extends to how a company and its partner companies treat their employees. Sustainable manufacturing is recognized as a necessary and good business practice. ARC sees the need for sustainable manufacturing driving a further increase in the need for product as well as process and equipment innovation.

The industry must focus on creating a culture of innovation and speed-to-market through automation and integration of R&D, manufacturing, and supply chain business processes in order to growth to ensure shareholder value.

From a high level perspective, the industry has done a good job at high volume manufacturing and streamlining transactions that have enabled the delivery of quality affordable products that meet the needs of the consuming public. Product innovation and speed-to-market have certainly been a part of this. While the global manufacturing and delivery infrastructure and practices are more or less developed, the industry has focused much less attention on the product-process-equipment innovation infrastructure

and practices that are needed in the current business environment. Over the past decade the industry strategy in general has been focused on product portfolio rationalization, productivity and continuous improvement initiatives, supply chain optimization, mergers, acquisitions, divestitures, and outsourcing. This has improved margins, but has not been the formula for sustainable profitable growth. Going forward, the industry has added a new focus on creating a culture of innovation and speed-to-market to

Product lifecycle management (PLM) software is being increasingly deployed by FMCG companies to enable more effective innovation, to reduce time to market, to manage costs, and to reduce brand risk.

further improve margins and to enable sustainable profitable growth that will ensure shareholder value. To achieve this they are further automating and integrating their R&D, manufacturing, and business processes on a global scale. The expanded strategy also includes global “super branding”, channel expansions, and more sustainable and flexible manufacturing and supply chains. Product lifecycle management (PLM) software, commonly seen as a core component of the IT architecture in the discrete industries, is being increasingly deployed by FMCG companies as a part of the new infrastructure and business model. Some of the important PLM solutions are for such things as portfolio management, new product development and introduction, stage gate management, recipe and formula management, package design, package artwork and labeling, specification development and management, sourcing, and supplier relationship management. Deployment and benefits can be surprisingly fast with proper problem definition and software selection. Yet PLM is a long-term strategic agenda with great benefits to be attained over time as companies use it to tie together business units and manufacturing sites and to implement common models, terminology, and work practices throughout the product and production processes.

Product lifecycle management (PLM) software is being increasingly deployed by FMCG companies as a part of the new infrastructure and business model. Some of the important PLM solutions are for such things as portfolio management, new product development and introduction, stage gate management, recipe and formula management, package design, package artwork and labeling, specification development and management, sourcing, and supplier relationship management. Deployment and benefits can be surprisingly fast with proper problem definition and software selection. Yet PLM is a long-term strategic agenda with great benefits to be attained over time as companies use it to tie together business units and manufacturing sites and to implement common models, terminology, and work practices throughout the product and production processes.



**Brand Promise and Reputation Are Being Sold on a Much Bigger and Global Scale**

## Unilever: A CPG Industry Success Story

Unilever faces similar challenges. Unilever’s brand portfolio spans 14 categories of home, personal care and food products and includes world favorites such as Lipton, Knorr, Dove, and Omo. The company employs 179,000 people in 100 countries worldwide. Its products are sold in the Americas, Europe and Asia/Africa in

roughly equal distribution. Like other large FMCG companies brand “promise” and “reputation” are being sold on a much bigger and global scale; and with it comes heightened expectations and greater brand risk. To achieve the business transformation necessary to ensure sustainable shareholder value, Unilever formalized their strategies into their One Unilever program that is focusing resources on brands, categories, and countries; a

Unilever recognized that common to addressing all these business challenges is the need for joined-up product information, organizationally, geographically, and across the full product lifecycle.

leaner, fitter business; and expansion in the developing and emerging markets. It is a restructuring program that included recognizing the crucial role technology plays in the quality of innovation.

Increasing consumer, business, and regulatory requirements are such that product information requirements are going exponential. Both current and new product innovation and portfolio management are important. Innovation is critical to sustaining Unilever’s growth. “We see product innovation as one of the key drivers of top-line growth,” says Huw Evans, R&D Director of Information in Unilever’s Home and Personal Care Division. However, Unilever’s complex SKU portfolio had no global standard set of terminology and models. There were many regional differences, making it difficult to react/respond to the market and to the changing cost and availability of raw materials in an effective and timely way. Global visibility of entire product portfolio and raw material specifications was needed.

Unilever recognized that common to addressing all these business challenges is the need for joined-up product information, organizationally, geographically, and across the full product lifecycle. This meant complete, integrated product information, managed and accessible across the business from ideation to product delisting. They didn’t want a static global specification document depository like other companies had deployed.

Unilever realized that PLM could be a technology enabled business change program that aligned with their One Unilever program.

They needed technology that would simplify and speed the process of “effective” global product, packaging, process, equipment, and machine innovation. They needed technology that would be a “change agent” to transform their business processes and culture. Unilever realized that PLM could be a technology enabled business

change program that supported their One Unilever program. Unilever decided to implement Siemens’ SIMATIC IT Interspec as a foundational step in their use of PLM technology. It was also the first step in what has become a long and successful software partnership with Siemens.

The story began over a decade ago working with Siemens on product specification management and the development of common models,

terminology, and work processes throughout Unilever. The sum of this effort was deployment of the SIMATIC IT Interspec specification development and management system. Through this Unilever was able to achieve global visibility for all raw material specifications and an order of magnitude reduction in the number of specifications in the organization. Since then it has become a key component of their product management system. Its tight integration with the supply chain ERP systems has saved time and resources through automated interfaces that eliminated double data entry and reduced errors. It was the first major step towards enhanced product traceability across

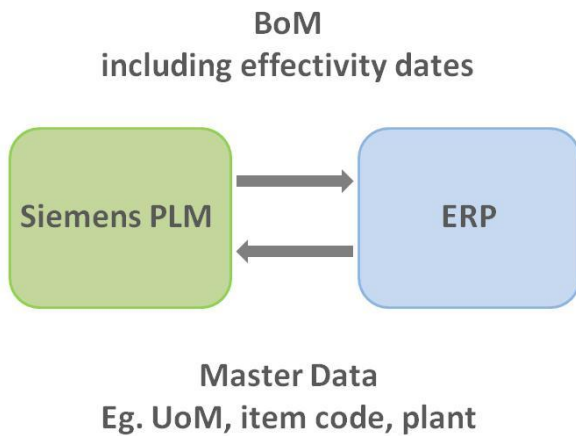

**Tight Integration with the Supply Chain  
ERP System Has Saved Time and Resources**

Unilever's supply chain and R&D systems.

At Unilever, packaging is one of the most dynamically changing parts of product design and one requiring long lead time because it involves so many organizations and activities prior to final approval and release. A package has more regional variations, in terms of labeling requirements, than the product contained within it. Most FMCG companies go through a major packaging redesign on all their major brands about every three years. With the current "green" packaging initiatives of major retailers like Wal-

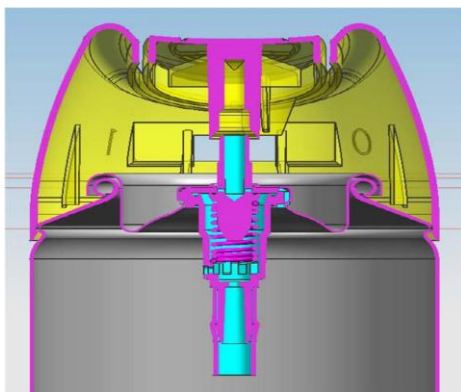

**Packaging is one of The Most  
Dynamically Changing Parts of  
Product Design**

Mart and Tesco and other initiatives to lower the carbon footprint, packaging design is in a constant state of change. New packaging designs must also take into account the ability of the manufacturing sites to handle the new design. There are conveyance issues, filling issues, and coding and labeling issues just to name a few. Packaging materials technology continues to evolve at a break neck pace, further adding to the complexity and rapid change.

It was easy to see why information management in the upstream packaging design process was a top priority at Unilever. In 2005 Unilever began working with Siemens' NX™ to play a key role in this process. NX™ embedded workflow processes, design rules, packaging shape design tools, and knowledge re-

use functionality led to impressive success in reducing design times and packaging costs. Unilever subsequently selected NX™ as their global, standard, package authoring tool.

Knowledge management played a major role in enabling Unilever to realize such benefits across the end to end package design process. Graham Blair of Unilever said, “During the evaluation for our next generation CAD system the ability to capture and reuse knowledge was a key consideration.

We were delighted and surprised at how well NX™ did this.”

Unilever was named Wal-Mart's 2007 supplier of the year for sustainable engagement and Tesco's international supplier of the year for the second year running.

The next logical step for Unilever was to share and manage the authored package designs throughout the enterprise. For this, Unilever again turned to Siemens, deciding upon Teamcenter™ as their standard tool for packaging process workflow and data management.

Teamcenter's product and production lifecycle data integration capability enables more effective global collaboration and will thus keenly support Unilever's product development philosophy. Aligned to the 'One Unilever' strategy, the roll out of Teamcenter™ for packaging data management will be in the global R&D centers across both Foods and HPC categories

Evidence of the ongoing transformation at Unilever can be seen in recent business performance and the recognition Unilever has received from its customers. In 2007 underlying sales grew by 5.5 for the third consecutive year of accelerating sales growth and operating margins improved. Unilever's growth was also broad-based across all major categories and regions. Furthermore, Unilever was named Wal-Mart's 2007 supplier of the year for sustainable engagement and Tesco's international supplier of the year for the second year running.

## Siemens PLM for the CPG Industries

Prior to Siemens' acquisition of PLM giant UGS in 2007, both Siemens and UGS could lay claim to an impressive list of FMCG customers who were delivering substantial, tangible benefits through the use of their respective PLM software. It is interesting to note that the two software portfolios were largely complementary in the context of an FMCG company, with Siemens owning proven tools for FMCG R&D organizations and UGS owning a scalable PLM architecture and a multitude of integrated, cross-industry applications such as project management, portfolio management, and supplier relationship management. Since the acquisition, Siemens has devoted substantial energy to combining these

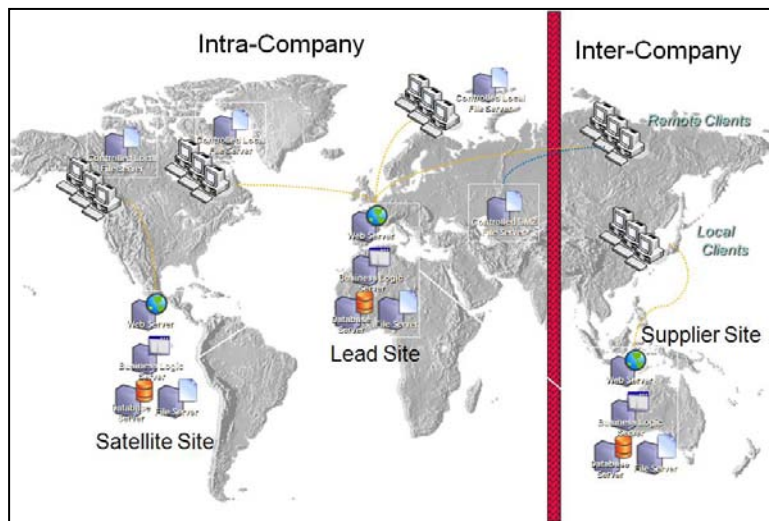

**Global Teamcenter Architecture Supports "Follow the Sun" Product Development**

complementary software assets to deliver a very complete and highly functional PLM solution for the industry.

Teamcenter™ is the foundation of the Siemens solution. It is, by design, the data management, collaboration management, security management and integration management nexus for the business processes and applications throughout product and production lifecycle. Teamcenter contains native applications for many of the

foundational tasks associated with product lifecycle management. Yet Siemens bills Teamcenter™ as an 'open' solution, and supports that with an extensive set of standards-based integrations to leading enterprise suites, including the ERP and desktop productivity vendors that are almost ubiquitous in large FMCG firms. Teamcenter boasts a modern, SOA-based architecture and more than 4 million licenses sold, making it the world's most widely used PLM solution. The Consumer Products Industry Data Model, is at the core to the Teamcenter scalable data backbone, offering a pre configured relational data model built on a detailed understanding of the behavior of a FMCG company, relating data from the perspective of brand, product, package, process, program, production, and plant.

The SIMATIC IT R&D Suite combines highly-usable solutions for specification development, formula development, electronic note booking, laboratory information management and batch scale-up, among other features.

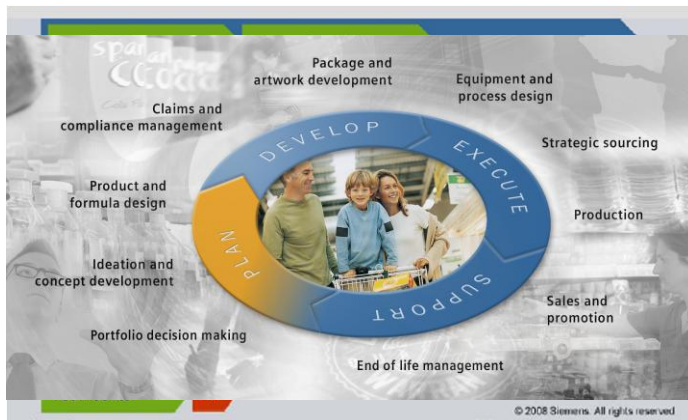

**The Teamcenter Platform is the Foundation that Enables the Entire Innovation Process**

The heart of the R&D Suite is the aforementioned Interspec, which provides a common global framework for specification development and management. It is a flexible and configurable template driven system that supports any product structure and geographic operating model. Via interface with Teamcenter, Siemens is able to deliver an integrated specification solution that gives developers digital access to consumer requirements and other critical data elements and documents that affect the developmental course of ingredient, package, and product specifications. ARC sees this as a

unique advantage in the Siemens approach.

NX™ is Siemens’s comprehensive CAD/CAM/CAE application that provides users with product design, product test, package design, and machine design capabilities. It provides overall design/specify/support collaboration and well as end-to-end workflow. Together, Teamcenter™ and NX™ provide a single source repository for package design and artwork information that has been the platform for substantial improvements in time to market, productivity and cost for Siemens’ FMCG customers. NX™ is particularly strong in packaging design due to its flexibility and shape creation capability. Some of its most important features include:

- Flexible shape creation for containers (i.e. designing a bottle shape that optimizes filling)
- Rendering for virtual 3D prototypes that can be tested and validated
- An embedded rules-based engine for knowledge capture
  - Enables users to input machine information to determine the capacity of machines or to determine which factories and which machines can handle a new design
  - Enables users to input material and product information to better calculate fill rate
- Product test applications
  - Finite Element Analysis (FEA)

- Computational Fluid Dynamics (CFD)
- Center of gravity, tip point, etc.
- Simulation capability for effect on fill rate, stacking capability, bottle movement through the packaging line, flow of plastic through mould machines, etc.

It also supports many different digital mockups thereby eliminating physical mock ups.

Siemens continues to enhance their PLM solution for FMCG companies in every functional area. ARC believes that some of the key enhancements for the FMCG industries will be in the areas of integration with third party providers for improved visualization, document management, and platform extensibility services including more third party support. Siemens is looking beyond the traditional confines of product lifecycle management to take its inspiration for future enhancements. The notion of 'brands' and the differences in the brand-driven product lifecycle is one such area that Siemens has pegged. It is ARC's opinion that this and recipe management are key differences between PLM for the discrete industries and PLM for the food, beverage, and FMCG industries. "We recognize that our customers are brand-driven, therefore our solutions have to recognize the way that this colors the product lifecycle." says Dan Staresinic, Siemens Worldwide Director for Consumer Products and Life Sciences, and long-time FMCG

"Our focus is Brand Lifecycle Management (BLM)" says Dan Staresinic, Siemens Global Director for Consumer Products.

"This simple shift takes us in a very unique direction.

practitioner. "This subtle shift takes us in a very unique direction. It forces us to think the way they think about the journey from idea to equity. It leads us to recognize each of the two dozen or more different functional disciplines that get involved in delivering profitable brand growth and to configure our solution to support the work that each one of them contributes along the way."

With many key brands you have many times many innovations flowing through the system at any given point in time. It is an enormous coordination challenge and a major reason that Unilever and the industry are recognizing the importance of the continued evolution of process PLM software.



3 ALLIED DRIVE DEDHAM MA 02026 USA 781-471-1000