

Solid Edge Diagramming

SIEMENS

White Paper

Integrated, process-specific diagramming for P&ID, electrical and hydraulic diagrams

Contents

- Integrated diagramming.....3**
 - Industry-standard blocks.....4
 - Fast, convenient access through EdgeBar.....4
- Conclusion.....7**

Integrated diagramming

Many companies are now switching to 3D design systems to cut costs, improve quality and remain competitive. The popular Siemens PLM Software Evolve to 3D program provides four easy steps that help many companies transition from 2D to 3D using a single, comprehensive design system. However, Siemens PLM Software recognizes that some design problems are still best solved using simple 2D geometry, such as machine layouts and schematic diagrams; Solid Edge® software includes tools for these tasks.

Solid Edge Diagramming allows you to develop electrical, P&ID and other diagrams by leveraging industry-standard libraries of 2D blocks and quickly connecting them together with associative connectors. Three main components make Solid Edge Diagramming so productive: blocks, connectors and the ability to convert native DWG blocks on the fly.

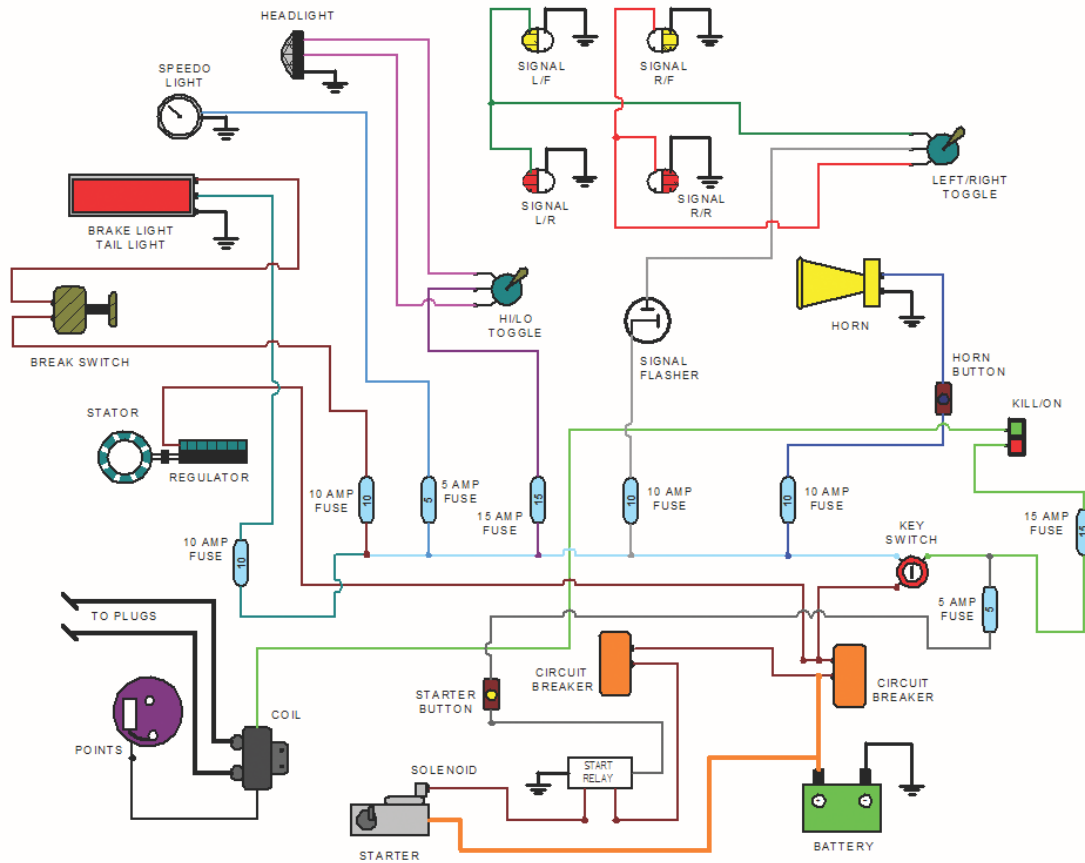

Industry-standard blocks

Diagramming uses industry-standard blocks (also referred to as symbols or cells) to automate the creation of basic electrical and P&ID diagrams in Solid Edge, without the need for a complete schematic system. Users simply drag-and-drop blocks into the Solid Edge drawing work space.

A block is composed of objects drawn on several layers with various colors, line types and line weight properties. Although a block is always inserted on the current layer, the block reference preserves information about the original layer, color and line type properties of the objects that are contained in the block.

Fast, convenient access through EdgeBar

The versatile Solid Edge EdgeBar delivers convenient navigation and fast access to blocks and block libraries. Blocks usually represent a much more complex component and are commonly used in electrical and P&ID diagrams. Blocks have several other special qualities. A single instance can be placed in many locations; these lightweight occurrences result in an efficient drawing format and reduced file size. Individual blocks can be replaced easily if their design changes. If a master occurrence is modified, all instances of the same symbol will be updated. Blocks also support multiple representations that can be placed in alternate positions. For example, the same symbol reference can show a switch in the open or closed position, facilitating accurate equipment lists.

Solid Edge Diagramming features

Blocks

Easy navigation of libraries with EdgeBar

- New preview

Drag-and-drop from EdgeBar

- CTRL drag, for quick copy/placement

Instancing – single copy, used in multiple locations

Supports multiple representations

Built-in block libraries

Extensive libraries of electrical, hydraulic, pneumatic and P&ID symbols are built directly into Solid Edge

Convert ACAD blocks directly to Solid Edge blocks

On-the-fly conversion from DWG

Connector object (faster more efficient)

Connect to any key-point

Lines, jumps, corners, steps, U-shapes

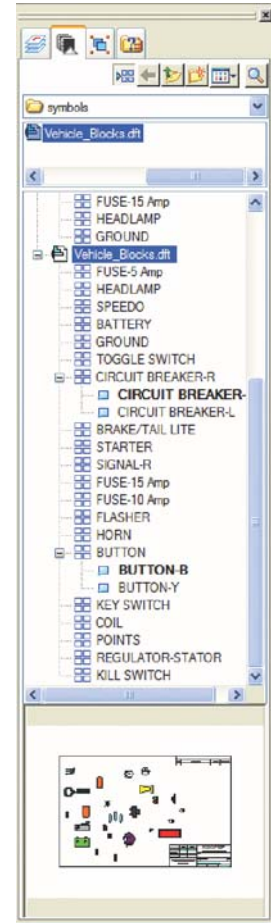

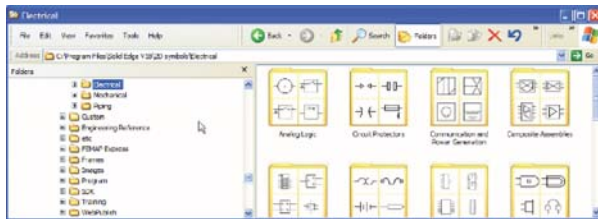

Built-in block libraries

Solid Edge is delivered with extensive libraries of electrical, hydraulic, pneumatic and P&ID symbols for electrical, mechanical schematics and piping (P&ID). Companies can also create their own standards. Using

a dedicated command, Solid Edge blocks are easy to create. Simply select the geometry and choose an insertion point, and the block is ready to be used. Blocks are free to be moved, mirrored and scaled. If a

- methods to create blocks:
- Combine objects to create a block definition in your current drawing
- Create a drawing file and later insert it as a block in other drawings
- Create a drawing file with several related block definitions to serve as a block library



Connectors

Blocks are joined together using connectors. A more lightweight and efficient version of a normal line, they behave very much like enhanced leader lines by snapping to all keypoint locations on a block. Connectors provide an efficient way of connecting blocks. There are four types of connector objects (lines, jumps, corners, steps and U-shapes) which are specifically designed to provide different options to quickly depict flow lines or schematic paths between blocks. Connectors are faster and more efficient than using lines to draw the same detail. Like any 2D drawings, diagrams will need to be edited at some time in their lifecycle. Editing is made quick and easy by the associative link created between connectors and blocks.

Convert thousands of industry-standard ACAD blocks on the fly

The ability to convert Autocad DWG blocks directly to Solid Edge blocks on the fly provides access to a rich resource of thousands of standard block libraries and allows users transitioning from AutoCAD to continue to use their legacy data and transition to 3D using one common design system. Layer, color, line type and weight mapping are honored during DXF/DWG import to Solid Edge.

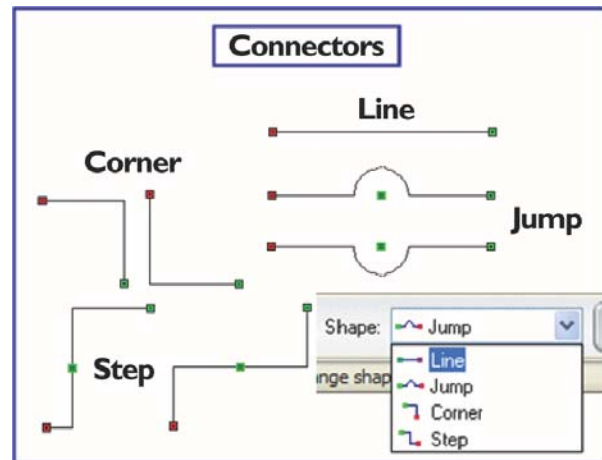

Conclusion

Solid Edge Diagramming allows you to quickly develop electrical, P&ID and other diagrams using industry-standard libraries of 2D blocks. These innovative 2D capabilities further strengthen Solid Edge ability to create and maintain 2D drawings – allowing you to work in both 2D and 3D using a single, dedicated CAD system.

About Siemens PLM Software

Siemens PLM Software, a business unit of the Siemens Industry Automation Division, is a leading global provider of product lifecycle management (PLM) software and services with 6.7 million licensed seats and more than 69,500 customers worldwide. Headquartered in Plano, Texas, Siemens PLM Software works collaboratively with companies to deliver open solutions that help them turn more ideas into successful products. For more information on Siemens PLM Software products and services, visit www.siemens.com/plm.

www.siemens.com/plm

All rights reserved. Siemens and the Siemens logo are registered trademarks of Siemens AG. D-Cubed, Femap, Geolus, GO PLM, I-deas, Insight, JT, NX, Parasolid, Solid Edge, Teamcenter, Tecnomatix and Velocity Series are trademarks or registered trademarks of Siemens Product Lifecycle Management Software Inc. or its subsidiaries in the United States and in other countries. All other logos, trademarks, registered trademarks or service marks used herein are the property of their respective holders.

© 2011 Siemens Product Lifecycle Management Software Inc.

X5 6380 6/11 B

Siemens Industry Software

Americas

1 800 807 2200

Fax 1 314 264 8922

Europe

+44 (0) 1202 243455

Fax +44 (0) 1202 243465

Asia-Pacific

852 2230 3308

Fax 852 2230 3210