

What does Siemens PLM Software's repeatable digital validation (RDV) framework mean to my bottom line?

SIEMENS

White Paper

Digital mockup (DMU) promised accelerating time-to-market and innovation, and ultimately, great real dollar returns. It kept much of that promise, within the constraints of existing computational capabilities. This report looks at those bottlenecks and at RDV, a new framework that allows DMU to move beyond computing limitations and sets the stage for even greater financial benefits.

Contents

- Executive summary 3
- The challenge: managing complexity in product development 4
- The Siemens PLM Software solution..... 6
- Cyon Research’s opinion of the Siemens PLM Software solution?..... 8

Executive summary

The software lets GM test and validate part designs in the context of an entire vehicle and any design changes that occur during the design cycle. Such efforts will save GM millions of dollars each year by improving accuracy. "What we're trying to promote is a continuous review," says Terry Kline, global information officer for product development at GM.

InformationWeek, February 23, 2004

"To optimize this aircraft for weight, cost and maintainability requires many, many design iterations. Typically, optimization is done by building and testing metal mockups and revising the design based on the results. By doing this work digitally, we cut an enormous amount of time out of the design cycle."

Dr. Oliver Masfield, senior vice president of engineering, Eclipse Aviation

Because its purpose is to create a customer, the business has two – and only two – basic functions: marketing and innovation. Marketing and innovation produce results; all the rest are "costs."

Peter Drucker

If Peter Drucker is right, the main contribution of engineering to a business' basic functions is enabling innovation. There are two broad types of innovation: new products and improvements for existing products. Most engineering organizations understand this point intuitively, but still focus sparingly on innovation. Why? Risk of failure. Failure is part of the process of innovation. Many engineering managers feel this will be counted against them, personally and departmentally, and most engineering cultures are not tolerant of frequent failure.

Reducing the risk of failure is a key to successful innovation and successful innovation leads to growth in sales. The goal of Siemens PLM Software's Repeatable Digital Validation framework – RDV – is to facilitate successful innovation.

What the RDV framework does is allow for the rapid analysis and validation of design alternatives (RAVDA). By making it possible for designers and engineers to quickly review and evaluate a design alternative with live data, RDV enables engineers to work on the design in progress, rather than analyzing and evaluating their innovation against a snapshot of what the design was at some point in the past.

RDV provides a framework for interacting with live data, along with a mechanism for automating the iterative aspects of validation. These two facilities greatly enhance the speed at which proposed changes can be validated.

The challenge: managing complexity in product development

The value of evaluating alternatives against live data should be obvious – it eliminates problems that might arise from unevaluated changes. Less obvious, but perhaps more critical to the innovation process, is the value of being able to explore many alternatives quickly. There is a correlation between the number of alternatives explored and the net innovation in the design process.

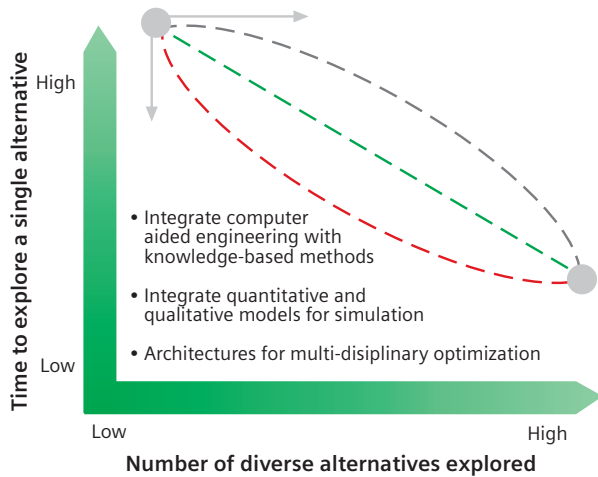

Figure 1: How time available affects innovation.

Source: DARPA RaDEO Project

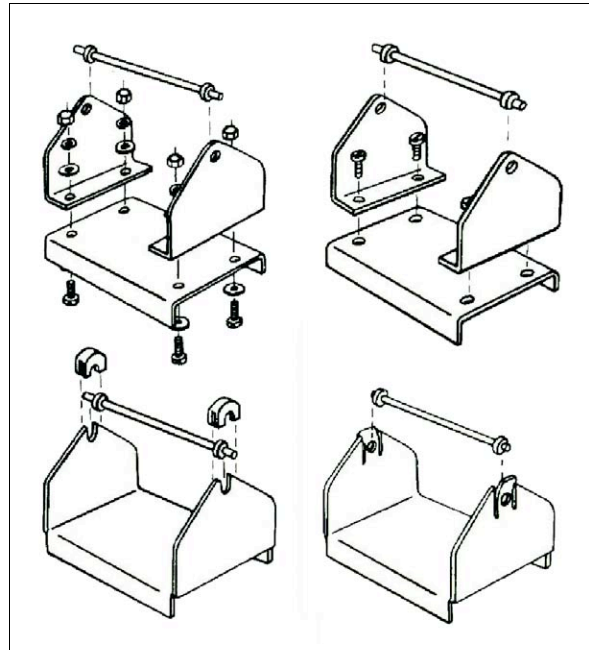

Figure 2: Innovation is enabled by evaluating more alternative concepts early in the design process. Here, part count is reduced from 24 to two.

Validation is a critical step. Without validation, the exploration of design alternatives is fruitless and expensive. As the chart below illustrates, the cost of an error rises rapidly as the phases of the engineering-to-manufacturing process progress. So discovering an invalid proposed change at the point of proposal, rather than at a later point in the process, can reduce its cost by orders of magnitude.

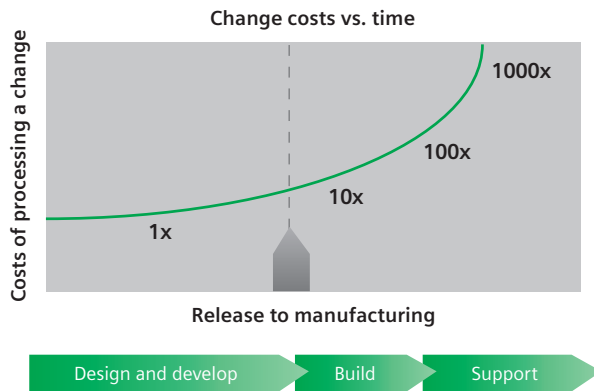

Figure 3: Impact of timing on the cost of making a change.

Source: Lean Manufacturing MIT

Designers have extensive toolsets for creating and innovating. Computer-aided design and computer-aided engineering analysis have been around for some time. They provide robust tools for dealing with individual parts and assemblies. But they are inadequate for dealing with complex products of high variability. Manufacturers of complex products, such as aircraft and automobiles, have long relied upon mockups – physical, usually full-size models – to explore many aspects of full-product integration. A longstanding goal of CAD vendors has been to supplant the expensive, hard-to-manage physical mockup with a digital mockup.

But this has proven to be a considerable challenge. The sheer volume of graphics, along with the underlying nongraphical data, for a plane, car or other complex system has been for the most part too much for standard computing systems. Available digital mockups have not completely replicated the functionality of physical mockups, despite many other advantages they offer, due to computational complexity. What they do, they do well – but after requesting a mockup “snapshot,” the engineer must wait for it to be produced. Meanwhile, others continue to evolve the design. So the DMU always lags behind the actual design.

The Siemens PLM Software solution

Physical mockups took time and mistakes were common. Digital mockup was supposed to ultimately eliminate the need for physical mockups. It has made things easier, but is still not "real time." And much of the impact of analysis – the validation – of a proposed change is still done manually. In other words, the impact of proposed changes – whether new design, alternate approaches or cross-product re-use – has to be examined in terms of all the parts of an existing design and all currently considered variations. We must answer the question, "What breaks if we do this?"

Consequently, changes are either not appropriately validated – leading to expensive recalls and rework – or they delay product releases, with potentially disastrous marketing results.

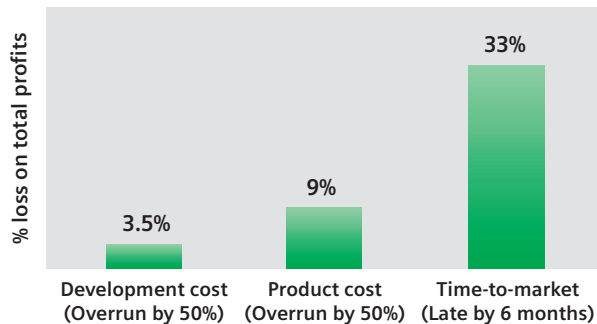

Figure 4: Time-to-market leverage vs. cost overruns.

Source: Revolutionizing Product Development, Wheelwright and Clark

Digital mockup promised great returns in reduced time-to-market, in innovation and ultimately to the bottom line. And it has kept many of those promises, reducing the number of physical mockups required and in some cases, eliminating them completely.

Business and engineering managers have long expected that the ability to completely model products, with all their variations, in the computer would simplify and streamline the product data management and validation processes.

There is nothing wrong with DMU technology per se. The challenge is that the market's accelerated product development, greatly shortened time-to-market and proliferation of product variations – along with increased product complexity – have exceeded the ability of DMU to respond in near-real time to validation requests. The combined effect of these factors is multiplicative, not just additive; the resulting computational demands are therefore orders of magnitude greater than they were when DMU was first introduced. So for DMU to take its next evolutionary step, there is a need to look to a conceptual change in how the product process is modeled.

Analysis and validation are keys to the innovation process. Analysis is straightforward – will the design perform to the required specifications? Typically this includes strength, rigidity, fatigue, acoustics and temperature analyses. Validation consists of three key components:

- Will the proposed change work?
- Does it meet the design criteria?
- Does it do so without introducing new problems elsewhere?

Products have become too complex, and variations too numerous, for existing systems to handle. Getting all of the required information into the digital mockup, and applying the analysis conditions and validation rules, can take as long as weeks – for each design alternative. Meanwhile, the design continues to progress. By the time the design in digital mockup has been analyzed and validated, thousands of other design changes will have been introduced.

Without a framework for rapid analysis and validation of live data, it will be impossible to meet market demands in a timely fashion. The consequence can be dramatic – often complete product failure and a loss of the development investment.

Eventually, computer power will increase enough to make current digital mockup approaches viable in a real-time context. But until then judicious application

of "shortcuts" in the form of more intelligent data handling tools must bridge the gap.

Rapid analysis and validation of design alternatives (RAVDA) is mission-critical for many organizations. Siemens' Repeatable Digital Validation is a process that unites a number of tools into a complete solution to address the RAVDA challenge. Cyon Research's opinion is that it goes a long way toward making the promise of real-time digital validation a usable reality. And only with RAVDA can engineers make their full potential contribution to the bottom line through cost savings (design time, reduced wasted design effort, reduced errors entering production) and through top-line revenue (earlier market entry with more innovation and higher quality means greater market share, greater revenue).

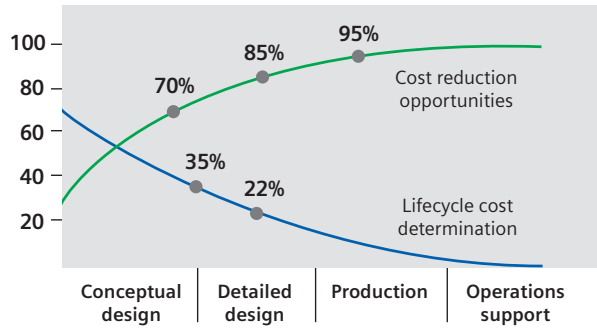

Figure 5: How the ability to influence total lifecycle costs changes over time.

Source: DARPA RaDEO Project

Cyon Research's opinion of the Siemens PLM Software solution?

RDV represents a major step forward in addressing complex product design, offering the kind of advanced change-impact analysis that standalone change management, virtual prototyping and PDM offerings can't.

To serve as the core of a viable business, engineering processes must have systems-level integrity. RDV takes a systems-based approach to managing the complexity in product design.

The profitability promise of PLM is held captive to the lack of a complete digital simulation solution. RDV is an important step toward such a solution: a comprehensive design model that is updated at every step and universally available to design teams.

Complete simulation is the end of CAD – its ultimate purpose. RDV is an important milestone on the road to that end.

Siemens PLM Software is careful to point out that RDV is a process, not a product. But it represents a comprehensive RAVDA framework for design validation, one that alleviates a major bottleneck in today's complex product design and production processes. It is clear that Siemens will continue to enhance RDV – and that users of RDV will see growing business benefits from it. Bottom line: enhanced innovation and profitability.

About Cyon Research

Cyon Research is a consulting firm that provides design, engineering, construction and manufacturing firms with a strategic outlook on the software tools and processes they rely on to create the world around us. Cyon Research also supports the vendor community with its unbiased insight, vision and expertise to help them understand the complex nature of their markets and grow by serving the needs of their customer base.

Cyon Research brings to its clients a unique combination of experience, perspective and insight, supported by an extensive network of well-established industry relationships. Our close contacts throughout the user, analyst, vendor and developer communities provide surprising benefits for our clients and add significant value to our services.

Those relationships are enhanced by our publications and events. While consulting is the heart of our activities, our publications and websites – including CAD/CAMNet, Engineering Automation Report and CADwire.net – are our voice. Through them, we connect daily and monthly with the user and vendor communities. And COFES: The Congress on the Future of Engineering Software, our annual, invitation-only event, is our face – the place where we can make the types of connections that just aren't possible through any other means than face-to-face.

The focus of our research within the realm of design, engineering, construction and manufacturing is technologies and markets that are likely to become real within the next two to six years.

The domain of our research is the tools, processes and procedures used in the design, engineering, management and production of the built environment and manufactured goods.

Funding for this white paper was provided in part by Siemens PLM Software. Watch CADwire.net for additional Cyon Research white papers.

Cyon Research Corporation
8220 Stone Trail Drive
Bethesda, MD 20817-4556 USA
Phone: 301-365-9085
Fax: 301-365-4586
www.cyonresearch.com

About Siemens PLM Software

Siemens PLM Software, a business unit of the Siemens Industry Automation Division, is a leading global provider of product lifecycle management (PLM) software and services with 6.7 million licensed seats and more than 69,500 customers worldwide. Headquartered in Plano, Texas, Siemens PLM Software works collaboratively with companies to deliver open solutions that help them turn more ideas into successful products. For more information on Siemens PLM Software products and services, visit www.siemens.com/plm.

Siemens PLM Software

Headquarters

Granite Park One
5800 Granite Parkway
Suite 600
Plano, TX 75024
USA
972 987 3000
Fax 972 987 3398

Americas

Granite Park One
5800 Granite Parkway
Suite 600
Plano, TX 75024
USA
800 498 5351
Fax 972 987 3398

Europe

3 Knoll Road
Camberley
Surrey GU15 3SY
United Kingdom
44 (0) 1276 702000
Fax 44 (0) 1276 702130

Asia-Pacific

Suites 6804-8, 68/F
Central Plaza
18 Harbour Road
WanChai
Hong Kong
852 2230 3333
Fax 852 2230 3210

www.siemens.com/plm

© 2010 Siemens Product Lifecycle Management Software Inc. All rights reserved. Siemens and the Siemens logo are registered trademarks of Siemens AG. D-Cubed, Femap, Geolus, GO PLM, I-deas, Insight, JT, NX, Parasolid, Solid Edge, Teamcenter, Tecnomatix and Velocity Series are trademarks or registered trademarks of Siemens Product Lifecycle Management Software Inc. or its subsidiaries in the United States and in other countries. All other logos, trademarks, registered trademarks or service marks used herein are the property of their respective holders.

X3 6210 12/10 C

Cyon Research

